

**AAMA/WDMA/CSA 101/LS.2/A440-08  
TEST REPORT**

**Rendered to:**

**EAGLE WINDOW & DOOR, INC.**

**SERIES/MODEL: Series 93 Clad Auxiliary Fixed  
PRODUCT TYPE: Aluminum Clad Fixed Wood Window**

<b>Title</b>	<b>Summary of Results</b>
Primary Product Designator	CW-PG55 1372 x 3658 (54 x 144)-FW*
Design Pressure	2640 Pa (55.0 psf)
Air Infiltration	<0.05 L/s/m <sup>2</sup> (<0.01 cfm/ft <sup>2</sup> )
Water Penetration Resistance Test Pressure	400 Pa (8.25 psf)
Uniform Load Structural Test Pressure	±3690 psf (±82.5 psf)
Forced Entry Resistance	Grade 10

**Test Completion Date:** 02/08/08

Reference must be made to Report No. 80184.01-201-44, dated 02/19/09 for complete test specimen description and data. Reference Architectural Testing, Inc. Report No. 71131.01-201-44, dated 03/15/07 for complete *Gateway* test specimen description and test results

**AAMA/WDMA/CSA 101/I.S.2/A440-08 TEST REPORT**

Rendered to:

EAGLE WINDOW & DOOR, INC.  
2045 Kerper Boulevard, P.O. Box 1072  
Dubuque, Iowa 52004-1072

Report No.: 80184.01-201-44  
Test Dates: 02/06/08  
Through: 02/08/08  
Original Report Date: 03/03/08  
Revised Report Date: 02/19/09  
Record Retention Date: 02/08/12

**Project Summary:** Architectural Testing, Inc. was contracted by Eagle Window & Door, Inc. to perform testing on a Series 93 Clad Auxiliary Fixed, Aluminum Clad Fixed Wood Window. The sample tested successfully met the performance requirements for CW-PG55 1372 x 3658 (54 x 144)-FW\* rating. Test specimen description and results are reported herein. Reference Architectural Testing, Inc. Report No. 71131.01-201-44, dated 02/19/09 for complete *Gateway* test specimen description and test results.

**General Note:** *An asterisk (\*) next to the size designation indicates that the size tested for optional performance was smaller than the Gateway test size for the product type and class.*

**Test Specification:** The test specimen was evaluated in accordance with AAMA/WDMA/CSA 101/I.S.2/A440-08, *NAFS - North American Fenestration Standard/Specification for Windows, Doors, and Skylights.*

**Test Specimen Description:**

**Series/Model:** Series 93 Clad Auxiliary Fixed

**Product Type:** Aluminum Clad Fixed Wood Window

**Overall Size:** 1372 mm (54") wide by 3658 mm (144") high

**Daylight Opening Size:** 1273 mm (50-1/8") wide by 3559 mm (140-1/8") high

**Overall Area:** 5.0 m<sup>2</sup> (54.0 ft<sup>2</sup>)

**Finish:** Interior wood was natural and the exterior aluminum cladding was white.

**Test Specimen Description:** (Continued)

**Frame Construction:** The wood frame was comprised of LVL with corners square cut, butted, sealed with silicone and secured with two 11 mm (7/16") crown by 38 mm (1-1/2") long staples per corner. Extruded aluminum cladding was slip-fit over the wood frame members with the corners miter cut, sealed with silicone and secured with a nylon corner key and two #6 by 11 mm (7/16") screws and one #10 by 64 mm (2-1/2") screw per corner.

**Weatherstripping:** No weatherstripping was utilized.

**Glazing:** The window utilized a nominal 25 mm (1") thick insulating glass fabricated from two sheets of nominal 5.7 mm (1/4") heat strengthened glass separated by an aluminum spacer system. The glass was set from the interior against butyl rubber mastic and silicone. Wood glazing stops with single sided adhesive foam tape were utilized on the interior and secured with 32 mm (1-1/4") brads spaced 25 mm (1") from each corner and 152 mm by 203 mm (6" to 8") on center.

**Drainage:** No drainage was utilized. OR A sloped sill was utilized.

**Hardware:** Hardware was utilized.

**Reinforcement:** No reinforcement was utilized.

**Installation:** The window was installed within wood test buck. The window was secured to the buck with an applied nailing fin which was set in silicone and secured with 51 mm (2") nails spaced approximately 152 mm (6") on center. Silicone sealant was also applied over the fastener heads. Masonry clips were utilized 610 mm (24") from each end of jamb and secured to the frame with four #8 by 16 mm (5/8") screws and to the wood surround with two #8 by 38 mm (1-1/2") screws.

**Test Results:** The temperature during testing was 21°C (70°F). The results are tabulated as follows:

<u>Paragraph</u>	<u>Title of Test - Test Method</u>	<u>Results</u>	<u>Allowed</u>
5.3.2	Air Infiltration per ASTM E 283		
	75 Pa (1.6 psf, 25 mph)	<0.05 L/s/m <sup>2</sup> (<0.01 cfm/ft <sup>2</sup> )	1.5 L/s/m <sup>2</sup> (0.30 cfm/ft <sup>2</sup> ) max.
	300 Pa (6.2 psf, 50 mph)	<0.05 L/s/m <sup>2</sup> (<0.01 cfm/ft <sup>2</sup> )	-- --

**Note #1:** The tested specimen meets (or exceeds) the performance levels specified in AAMA/WDMA/CSA 101/I.S.2/A440-08 for air leakage resistance.

**Test Results:** (Continued)

<u>Paragraph</u>	<u>Title of Test - Test Method</u>	<u>Results</u>	<u>Allowed</u>
5.3.3.2	Water Resistance per ASTM E 547 and ASTM E 331		See Note #2
5.3.4.2	Uniform Load Deflection per ASTM E 330		See Note #2
5.3.4.3	Uniform Load Structural per ASTM E 330		See Note #2

**Note #2:** *The client opted to start at a pressure higher than the minimum required. Those results are listed under Optional Performance.*

5.3.5	Forced Entry Resistance per ASTM F 588-04		
	Type: D	Grade: 10	
	Disassembly Test	No entry	No entry
	Lock Hardware Manipulation Test	No entry	No entry

Optional Performance

4.3.2.1	Water Resistance per ASTM E 547 and ASTM E331 400 Pa (8.25 psf)	No leakage	No leakage
4.3.2.1	Uniform Load Deflection per ASTM E 330 (Deflections reported were taken on the frame) (Loads were held for 60 seconds)		
	2640 Pa (55.0 psf) (positive)	0.3 mm (0.01")	4.6 mm (0.18") max.
	2640 Pa (55.0 psf) (negative)	0.3 mm (0.01")	4.6 mm (0.18") max.
4.3.2.1	Uniform Load Structural per ASTM E 330 (Permanent set reported were taken on the frame) (Loads were held for 10 seconds)		
	3960 Pa (82.5 psf) (positive)	0.3 mm (0.01")	2.5 mm (0.10") max.
	3960 Pa (82.5 psf) (negative)	<0.3 mm (<0.01")	2.5 mm (0.10") max.

Tape and film were used to seal against air leakage during structural testing. In our opinion, the tape and film did not influence the results of the test.

**Drawing Reference:** The test specimen drawings have been reviewed by Architectural Testing, Inc. and are representative of the test specimen reported herein.

**List of Official Observers:**

<u>Name</u>	<u>Company</u>
Chad Cornell	Eagle Window & Door
Jim Welter	Eagle Window & Door
Anthony D. Gavin	Architectural Testing, Inc.
Karl A. Lips-Eakins	Architectural Testing, Inc.
Eric J. Schoenthaler	Architectural Testing, Inc.

Detailed drawings, data sheets, representative samples of test specimens, a copy of this report, or other pertinent project documentation will be retained by Architectural Testing, Inc. for a period of four years from the original test date. At the end of this retention period, such materials shall be discarded without notice and the service life of this report will expire.

Results obtained are tested values and were secured by using the designated test methods. No conclusions of any kind regarding the adequacy or inadequacy of the glass in the test specimen can be made. This report does not constitute certification of this product nor an opinion or endorsement by this laboratory. It is the exclusive property of the client so named herein and relates only to the specimen tested. This report may not be reproduced, except in full, without the written approval of Architectural Testing, Inc.

For ARCHITECTURAL TESTING, INC.

---

Eric J. Schoenthaler  
Project Manager

---

Daniel A. Johnson  
Director - Regional Operations

EJS/mb;jb

Attachments (pages): This report is complete only when all attachments listed are included.

- Appendix-A: Alteration Addendum (1)
- Appendix-B: WDMA Submittal Form (2)
- Appendix-C: Drawings (9)

### Revision Log

<b><u>Rev. #</u></b>	<b><u>Date</u></b>	<b><u>Page(s)</u></b>	<b><u>Revision(s)</u></b>
0	03/03/08	N/A	Original report issue. Report and drawings forwarded to AMS for Hallmark Certification.
1	04/08/08	Page 2	Removed weatherstrip paragraph. Report and drawings forwarded to AMS for Hallmark Certification.
2	11/24/08	All	Test Report results conducted prior to 2008 standard being published; report is as compared to 2008 standard. Report and drawings forwarded to AMS for Hallmark Certification.
3	02/19/09	Cover and page 1	Corrected Gateway reference report number. Changed classification. Report and drawings forwarded to AMS for Hallmark Certification.

**Appendix A**  
**Alteration Addendum**

*Note: No alterations were required,*

**Appendix B**  
**WDMA Submittal Forms**



# WDMA HALLMARK CERTIFICATION PROGRAM REPORT SUBMISSION FORM

THIS FORM IS TO BE COMPLETED BY THE MANUFACTURER AND SUBMITTED TO AMS PRIOR TO OR ALONG WITH SUBMISSION OF EACH NEW OR REVISED TEST REPORT FOR CERTIFICATION TO THE HALLMARK PROGRAM. ANY QUESTIONS PLEASE CONTACT AMS AT 315-646-2234 OR [staff@amscert.com](mailto:staff@amscert.com).

Manufacturer: Eagle Window and Door, Inc.

Contact: Todd Bergstrom

Plant Location(s):  
(list all plants where product is made)  
2045 Kerper Blvd., Dubuque, IA 52004-1072

Phone: 563-556-2270

Test Report #: 80184.01-201-44-R2

Email: tbergstrom@eaglewindow.com

Product Relationship:

Extension of currently certified product?  yes  no  n/a      Recertification  New  (check one)

If yes, what CCL # ? 099-H-678.03

Difference from Certified Product: Report re-written to A440.08 standard.

Is this a Gateway Test ?  yes  no  n/a

Does this report require a Gateway Report # ?  yes  no  n/a      Report #: 71131.01-201-44

Impact Report:

If this is not an impact report check here:

AWS Report # \_\_\_\_\_

Test Plan # ?  yes  no  n/a \_\_\_\_\_

Installation Instructions submitted ?  yes  no  n/a

Certification to Florida:

If this will not be submitted to Florida check here:

AMS to Input to Database  yes  no  n/a

Manufacturer to input  yes  no  n/a



# WDMA HALLMARK CERTIFICATION PROGRAM REPORT SUBMISSION FORM

Product Name: Series 93 Clad Auxiliary Fixed  
(as to be listed on CCL)

Product Type: Fixed Window

Additional Manufacturer ID #: \_\_\_\_\_

n/a

<u>Hallmark CCL</u>	<u>Standard</u>	<u>Rating</u>
<input type="checkbox"/>	ANSI/AAMA/NWWDA 101/I.S. 2 97	_____
<input type="checkbox"/>	101/I.S.2/NAFS-02	_____
<input type="checkbox"/>	AAMA/WDMA/CSA/101/I.S.2/A440-05	_____
<input checked="" type="checkbox"/>	AAMA/WDMA/CSA/101/I.S.2/A440-08	CW-PG55 1372 x 3658 (54 x 144)-FW*
<input type="checkbox"/>	ASTM E 1996 99 / E1886-97	_____
<input type="checkbox"/>	ASTM E 1996 01 / E1886-97	_____
<input type="checkbox"/>	ASTM E 1996 02 / E1886-02	_____
<input type="checkbox"/>	ASTM E 1996 03 / E1886-02	_____
<input type="checkbox"/>	ASTM E 1996 04 / E1886-04	_____
<input type="checkbox"/>	ASTM E 1996 05 / E1886-05	_____
<input type="checkbox"/>	ASTM E330 02	_____
<input type="checkbox"/>	ANSI A250.13-03	_____
<input type="checkbox"/>	TAS 201-94	_____
<input type="checkbox"/>	TAS 202-94	_____
<input type="checkbox"/>	TAS 203-94	_____

## **Appendix C**

### **Drawings**

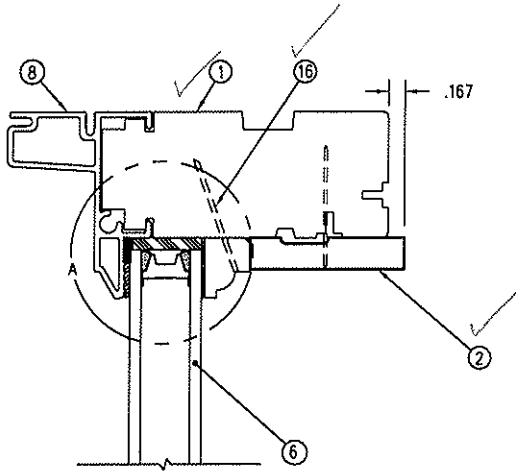

SECTION A-A

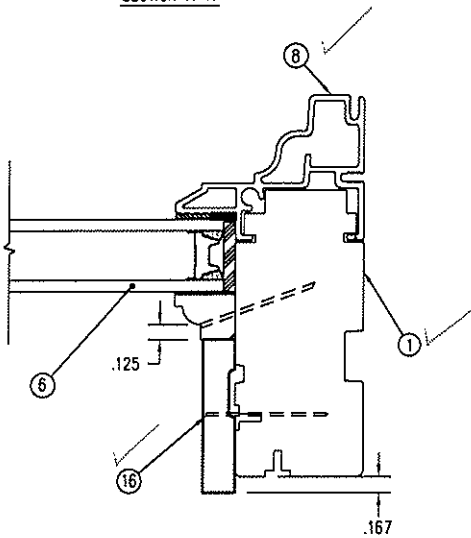

SECTION B-B  
(OPTION W/ D-H PROFILE)

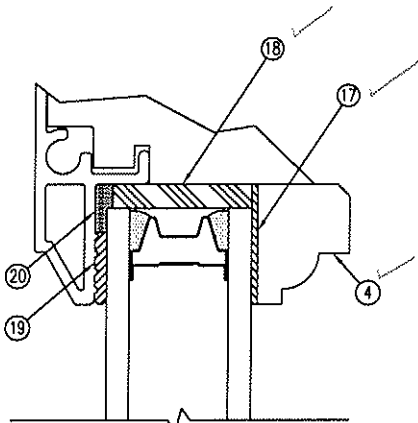

DETAIL A  
SHOWN W/ COLONIAL GLASS STOP  
SCALE X 2

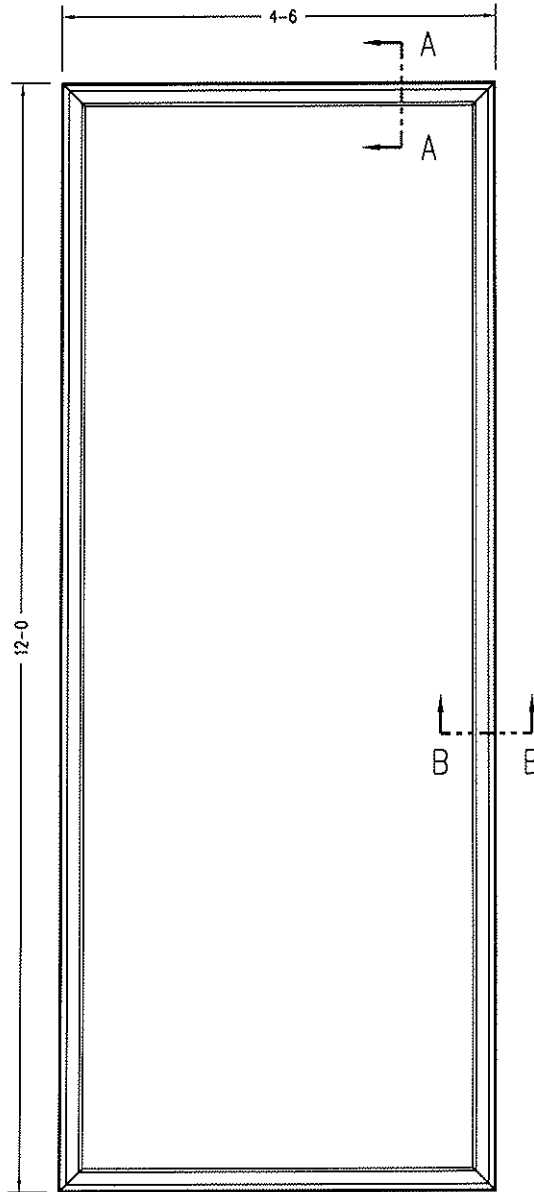

EXTERIOR VIEW



Architectural Testing

Test sample complies with these details.  
Deviations are noted.

Report# 80184  
Date 2/6/08 Tech APK

THIS DRAWING AND ITS CONTENTS ARE THE PROPERTY OF EAGLE WINDOW & DOOR. NO USE OR REPRODUCTION OF THE CONTENTS OF THIS DOCUMENT IS PERMITTED WITHOUT THE EXPRESS WRITTEN PERMISSION OF EAGLE WINDOW & DOOR.			
TITLE: CLAD AUXILIARY UNIT ASSEMBLY			
FINISH:			
MATERIAL:			
DFT:	CRC	SCALE:	1=2
DCN:	0710	DRWG:	055G
DATE:	1/4/08	C	01 OF 05

NO.	DESCRIPTION	DFT	DOC	DATE

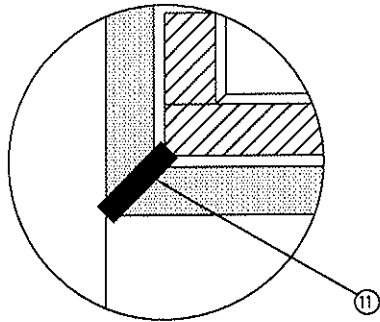

DETAIL A

.392 DIA. x 82' CSK  
(4 PLCS)

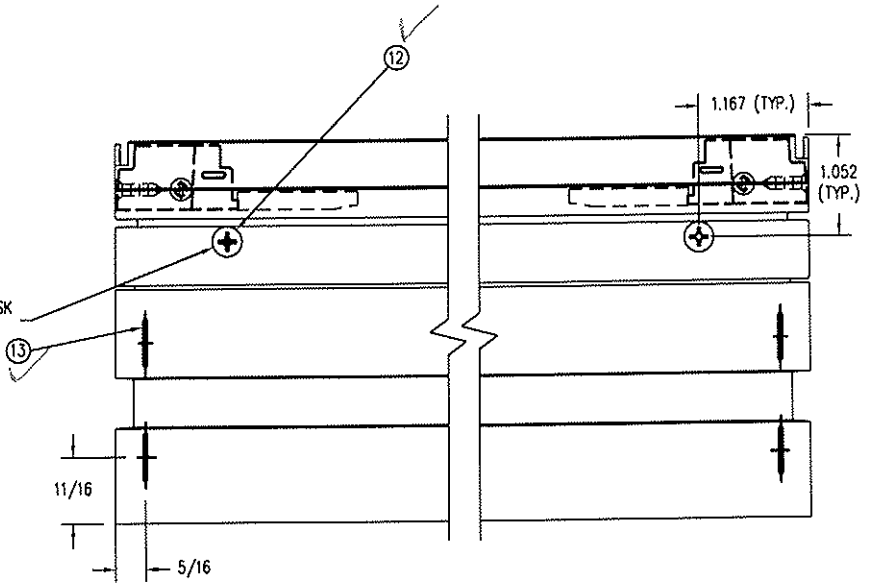

Architectural Testing

Test sample complies with these details.  
Deviations are noted.

Report# 80184  
Date 2/6/08 Tech JFK

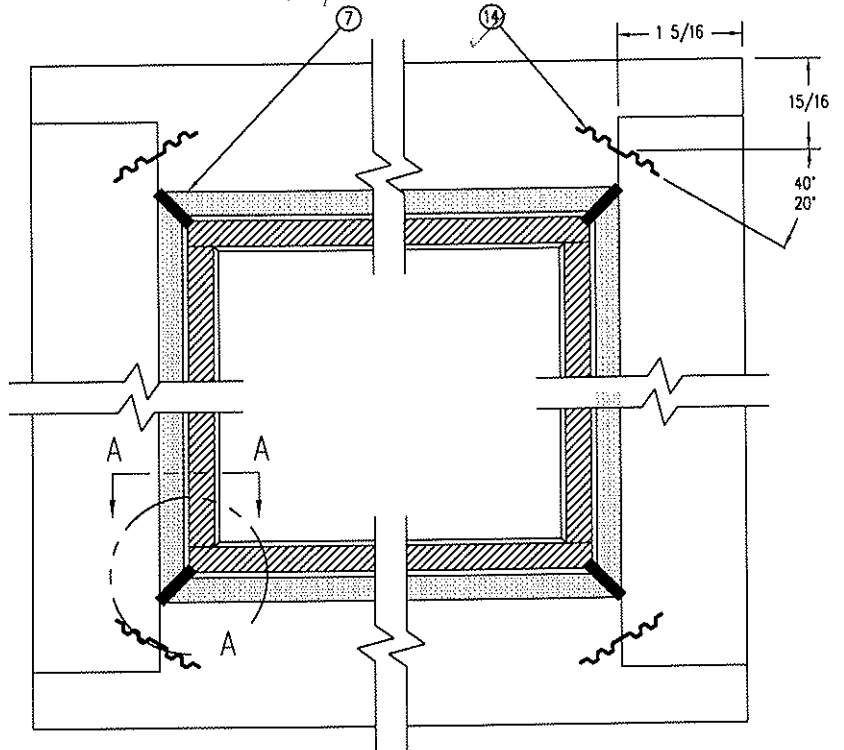
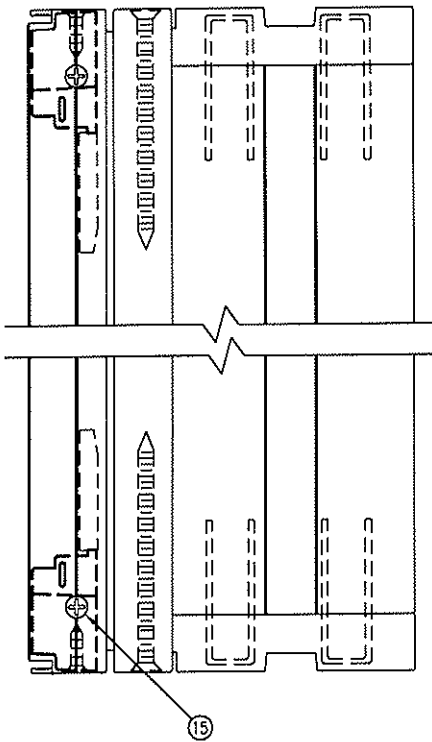

INTERIOR VIEW SHOWN WITHOUT GLASS OR STOPS

THIS DRAWING AND ITS CONTENTS ARE THE PROPERTY OF  
EAGLE WINDOW & DOOR. NO USE OR REPRODUCTION OF THE  
CONTENTS OF THIS DOCUMENT IS PERMITTED WITHOUT THE  
EXPRESS WRITTEN PERMISSION OF EAGLE WINDOW & DOOR.

TITLE: CLAD AUXILIARY UNIT  
ASSEMBLY

FINISH:

MATL:

DFT: CRC SCALE: 1=2

DCN: 0710 DRWG: 055C

DATE: 1/4/08 C 03

NO	DESCRIPTION	DFT	DOC	DATE

1. CENTER NAIL FIN, PLACE NAIL IN FIRST HOLE AND THEN EVERY OTHER THERE AFTER. 2" ROOFING NAILS THROUGH NAIL FIN INTO WALL.

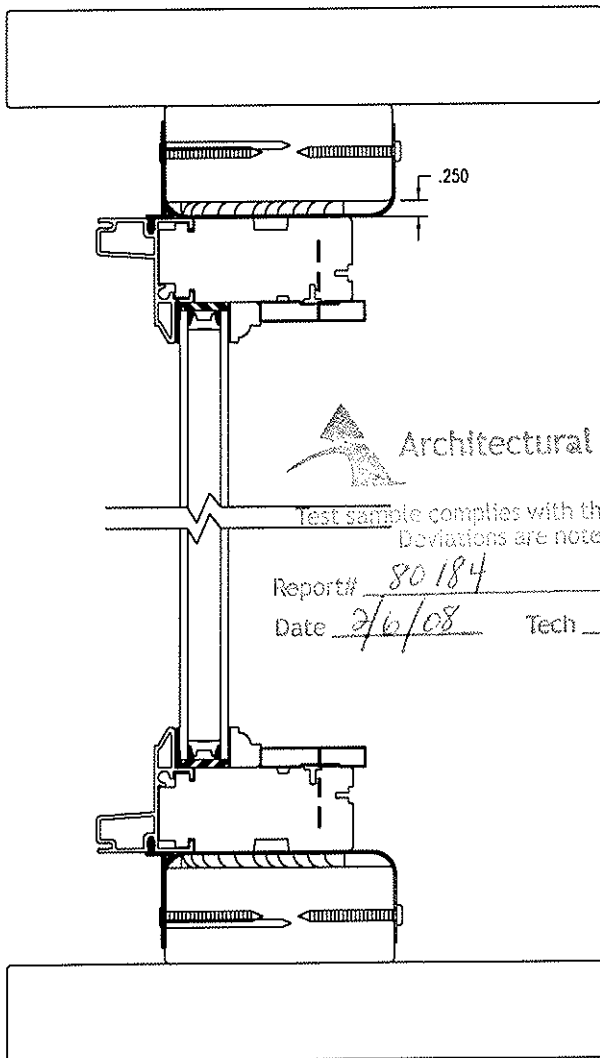
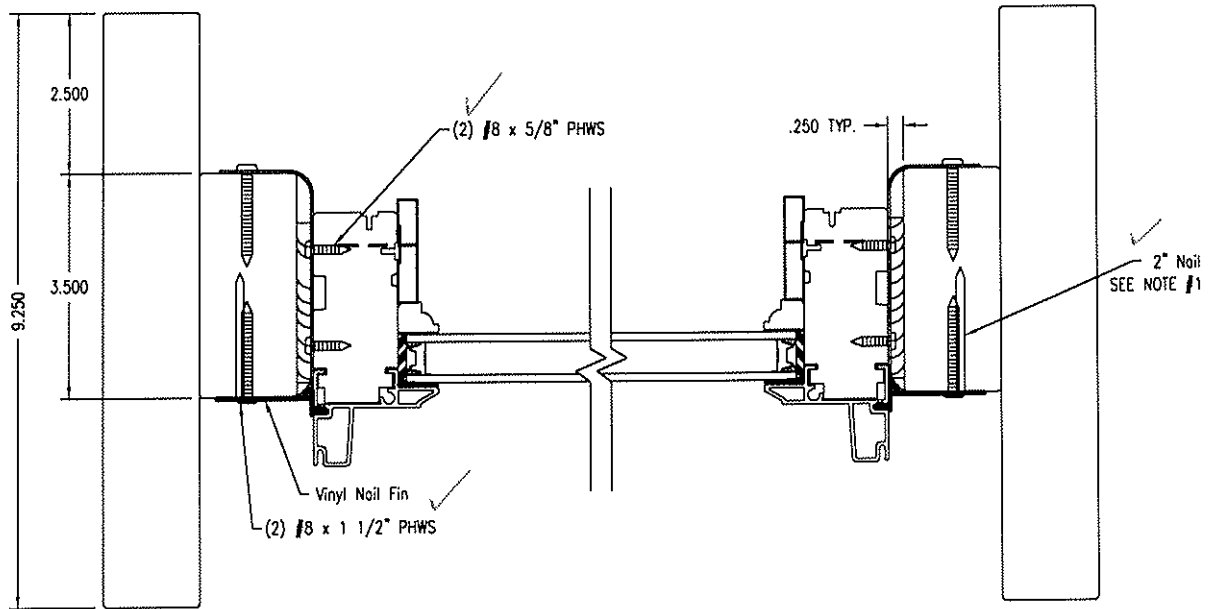

SECTION A-A

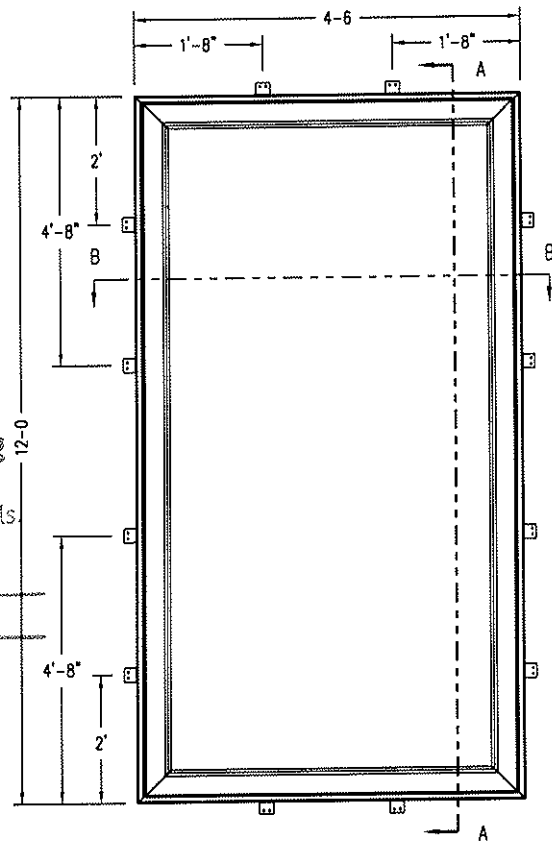

EXTERIOR VIEW

 Architectural Testing

Test sample complies with these details  
Deviations are noted.

Report# 80184  
Date 7/6/08 Tech DDK

THIS DRAWING AND ITS CONTENTS ARE THE PROPERTY OF EAGLE WINDOW & DOOR. NO USE OR REPRODUCTION OF THE CONTENTS OF THIS DOCUMENT IS PERMITTED WITHOUT THE EXPRESS WRITTEN PERMISSION OF EAGLE WINDOW & DOOR.			
TITLE: CLAD AUXILIARY INSTALLATION DETAIL			
FINISH:			
MATERIAL:			
DFT:	CRC	SCALE:	1=3
DCN:	0710	DRWG:	055D
DATE:	12/27/07	C	03 OF 03

NO	DESCRIPTION	DFT	DOC	DATE

NO.	DWG. NO.	DESCRIPTION	QUANTITY	MATERIAL	SUPPLIER
✓ 1	220C	FRAME MEMBERS	4	WOOD (LVL)	EAGLE WINDOW AND DOOR
✓ 2	203B	SECONDARY STOP	4	WOOD	EAGLE WINDOW AND DOOR
3					
✓ 4	220J	COLONIAL GLAZING STOP	4	WOOD	EAGLE WINDOW AND DOOR
5					
6	A019	INSULATED GLASS	1	GLASS	CARDINAL IG
	A32Y	MONOLITHIC	1	GLASS	CARDINAL IG
	A024	MDL GLASS	1	GLASS	CARDINAL IG
7	A030	SILICONE SEALANT	AS REQUIRED	SILICONE	DOW CORNING
✓ 8	A554	AUXILIARY FRAME CLADDING	4	ALUMINUM	BONNELL
	A555	DH AUXILIARY FRAME CLADDING	4	ALUMINUM	BONNELL
9	A08W	CORNER KEY	4	ABS COMPOUND	LAKE COUNTRY SALES
10	A100	90° NYLON FRAME CORNER	4	NYLON	LAKE COUNTRY SALES
11	A24Y	SEAM SEALER SEALANT	AS REQUIRED	POLYETHELENE	SCHNEE-MOREHEAD
12	A046	#10 X 2 1/2 SS SMS	4	STEEL	ABILITY FASTENERS
13	A15Y	7/16" X 1 1/2" STAPLE	8	STEEL	PACKAGING CORP.
14	A02Y	1/2" X 1" CORRUGATED FASTNER	4	STEEL	PACKAGING CORP.
15	A11K	#8 x 7/16" PHIL. #6 FH. WS.	8	STEEL	ABILITY FASTENERS
16	A40F	1 1/4" HARDENED STEEL BRAD (18GA.)	AS REQUIRED	STEEL	
17	A67M	ADHESIVE FOAM TAPE	AS REQUIRED	POLYETHELENE	ADHESIVE RESEARCH
18	A00E	GLASS SETTING, NEOPRENE	AS REQUIRED	NEOPRENE RUBBER	CLIM-A-TECH
19	A01A	SEALANT BUTYL TAPE	AS REQUIRED	BUTYL RUBBER	PTI INC.
20	A08K	GLAZING SHIM	AS REQUIRED	NEOPRENE RUBBER	CLIM-A-TECH
21	H-40	5/8" BETWEEN GLASS MUNTIN	AS REQUIRED	ALUMINUM	ALLMETAL
22	P/PD	1" CONTOUR MUNTIN	AS REQUIRED	ALUMINUM	ALLMETAL
23	220H	1 1/2" INTERIOR COLONIAL MDL BAR	AS REQUIRED	WOOD	EAGLE
24	H-40	SPACER CHANNEL	AS REQUIRED	ALUMINUM	ALLMETAL
25	A507	1 1/2" EXTERIOR MDL BAR	AS REQUIRED	ALUMINUM	HYDRO
26	A67X	1 1/2" MDL ADHESIVE TAPE (EXT. TAPE)	AS REQUIRED	POLYETHELENE	ADHESIVE RESEARCH
27	A67L	1 1/2" MDL ADHESIVE TAPE (INT. TAPE)	AS REQUIRED	POLYETHELENE	ADHESIVE RESEARCH
28	220H	1 1/8" INTERIOR COLONIAL MDL BAR	AS REQUIRED	WOOD	EAGLE
29	H-40	SPACER CHANNEL	AS REQUIRED	ALUMINUM	ALLMETAL
30	A507	1 1/8" EXTERIOR MDL BAR	AS REQUIRED	ALUMINUM	HYDRO
31	A67W	1 1/8" MDL ADHESIVE TAPE (EXT. TAPE)	AS REQUIRED	POLYETHELENE	ADHESIVE RESEARCH
32	A67R	1 1/8" MDL ADHESIVE TAPE (INT. TAPE)	AS REQUIRED	POLYETHELENE	ADHESIVE RESEARCH
33	220H	7/8" INTERIOR COLONIAL MDL BAR	AS REQUIRED	WOOD	EAGLE
34	H-40	SPACER CHANNEL	AS REQUIRED	ALUMINUM	ALLMETAL
35	A507	7/8" EXTERIOR MDL BAR	AS REQUIRED	ALUMINUM	CAM-KIU
36	A67T	7/8" MDL ADHESIVE TAPE (EXT. TAPE)	AS REQUIRED	POLYETHELENE	ADHESIVE RESEARCH
37	A67N	7/8" MDL ADHESIVE TAPE (INT. TAPE)	AS REQUIRED	POLYETHELENE	ADHESIVE RESEARCH
38	N/A	ADHESIVE FOAM TAPE	AS REQUIRED	POLYETHELENE	CARDINAL
39	H-40	SPACER CHANNEL	AS REQUIRED	ALUMINUM	ALLMETAL
40	A72D	5/8" EXTERIOR MDL BAR	AS REQUIRED	ALUMINUM	COLONIAL CRAFT
41	A75N	5/8" MDL ADHESIVE TAPE (EXT. TAPE)	AS REQUIRED	POLYETHELENE	ADHESIVE RESEARCH
42	A75M	5/8" MDL ADHESIVE TAPE (INT. TAPE)	AS REQUIRED	POLYETHELENE	ADHESIVE RESEARCH
43	20FA	5/8" INTERIOR COLONIAL MDL BAR	AS REQUIRED	WOOD	EAGLE



## Architectural Testing

Test sample complies with these details.  
Deviations are noted.

Report# 80184  
Date 2/6/08 Tech JPK

THIS DRAWING AND ITS CONTENTS ARE THE PROPERTY OF EAGLE WINDOW & DOOR. NO USE OR REPRODUCTION OF THE CONTENTS OF THIS DOCUMENT IS PERMITTED WITHOUT THE EXPRESS WRITTEN PERMISSION OF EAGLE WINDOW & DOOR.			
TITLE: CLAD AUXILIARY UNIT ASSEMBLY			
FINISH:			
MATL:			
DFT:	CRC	SCALE:	1=2
DCN:	0710	DRWG:	055C
DATE:	1/4/08	C	05

NO	DESCRIPTION	DFT	DOC	DATE

Note: 1 UNLESS OTHERWISE SPECIFIED, ALL DIMENSIONS ARE SHOWN ARE IN INCHES AND ALL TOLERANCES ARE TO BE:  
 DEC.+/- .005, FRACTION +/- 1/64, ANGLES +/- 1/2.

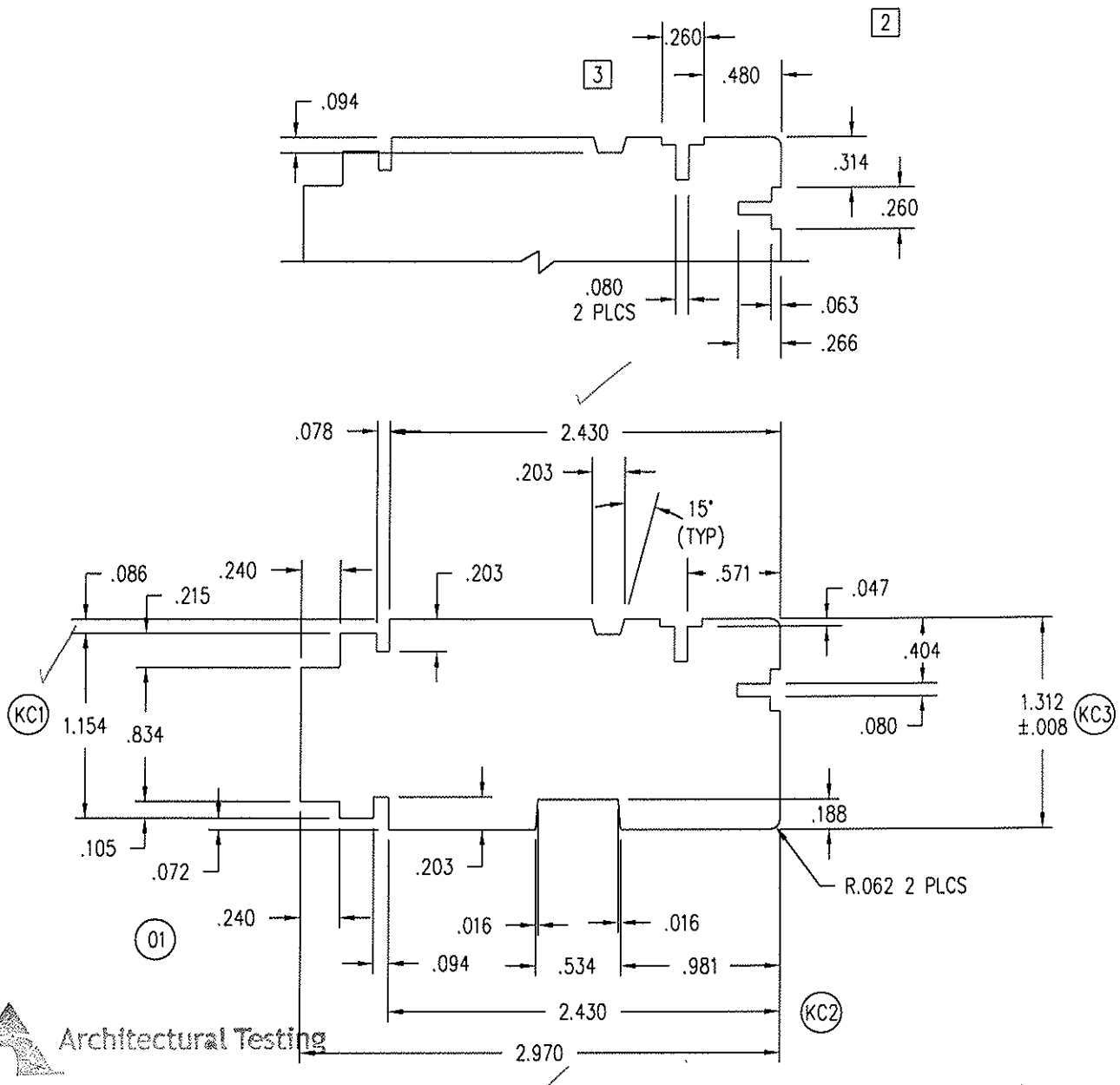

**Architectural Testing**  
 Test sample complies with these details.  
 Deviations are noted.

Report# 80184  
 Date 2/6/08 Tech gpk

03	REMOVED 2 KERFS.	RDA	1005	12/05/05
02	REVISED PROFILE - ADDED CONCEALED FASTENER ROUT	RDA	0925	09/30/04
01	ADD .105 x .240 PLOW	AWW	0752	12/03/02
NO	Description of Change	Drafter	DCN#	Date

Title: AUXILIARY FRAME		Finish:	Material: SEE PAGE 02
Scale: 1=1	Date: 4/26/2002	THIS DRAWING AND ITS CONTENTS ARE THE PROPERTY OF EAGLE WINDOW & DOOR. NO USE OR REPRODUCTION OF THE CONTENTS OF THIS DOCUMENT IS PERMITTED WITHOUT THE EXPRESS WRITTEN PERMISSION OF EAGLE WINDOW & DOOR.	
Drafter: AWW	DCN# 0683		

NOTE: 1. UNLESS OTHERWISE SPECIFIED, ALL DIMENSIONS SHOWN ARE IN INCHES AND ALL TOLERANCES ARE TO BE: DEC.  $\pm 0.005$ ; FRAC.  $\pm 1/64$ ; ANGLES  $\pm 1/2^\circ$ .  
 2. UNLESS OTHERWISE SPECIFIED, WALL THICKNESS IS .055.  
 3. UNLESS OTHERWISE SPECIFIED, BREAK ALL CORNERS .015 RADIUS.

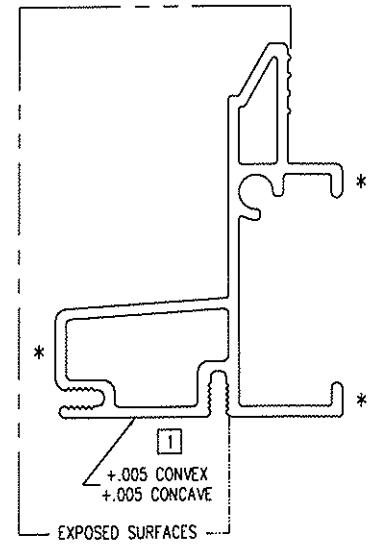
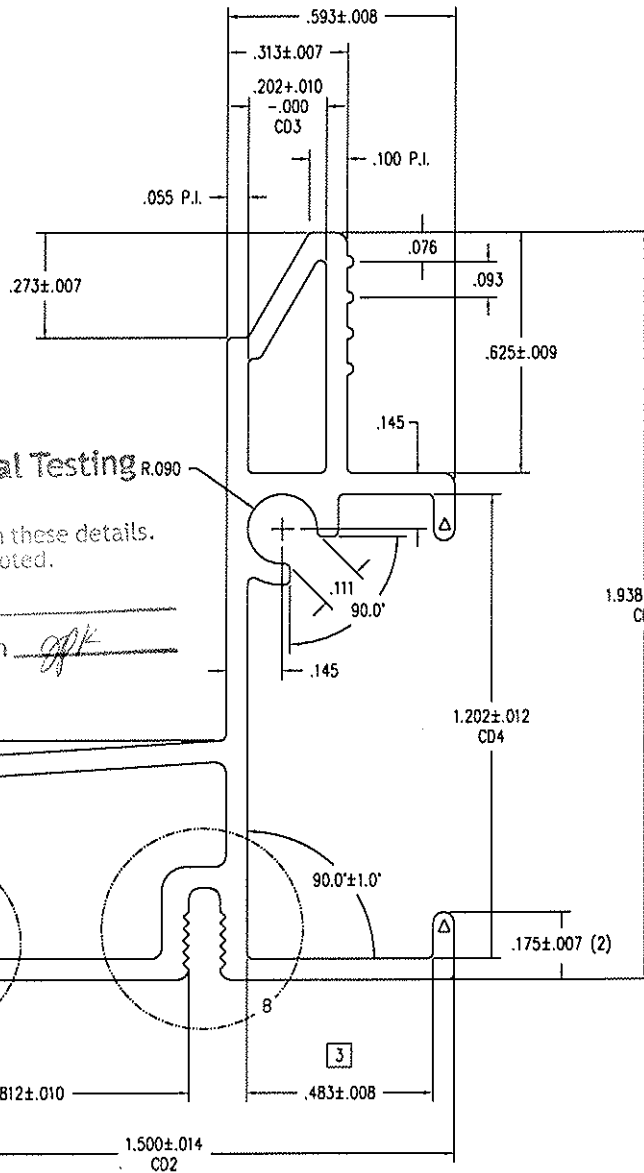

\* = PERPENDICULAR WITHIN 1.0' TO FLAT SURFACE

- R .028 (11)
- R .031 (2)
- X R .062 (3)
- △ FULL RAD.(1)

**Architectural Testing** R.090

Test sample complies with these details.  
 Deviations are noted.

Report# 80184  
 Date 2/6/18 Tech gfk

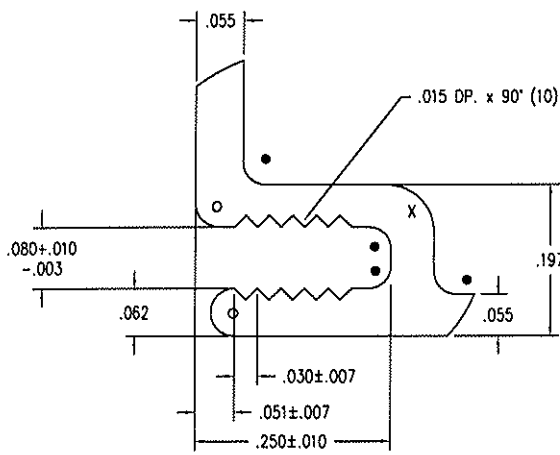

DETAIL "A"

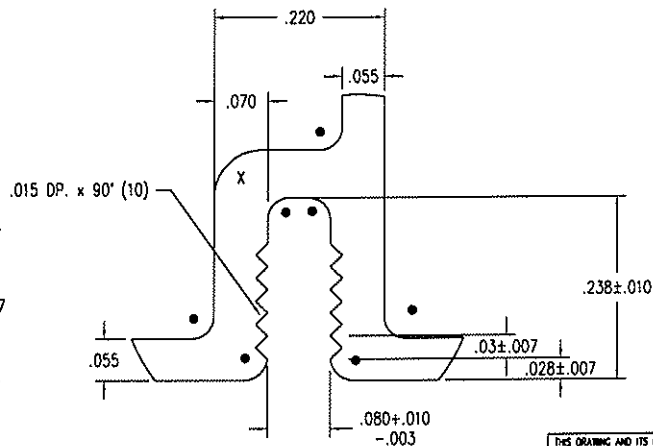

DETAIL "B"

THIS DRAWING AND ITS CONTENTS ARE THE PROPERTY OF EAGLE WINDOW & DOOR. NO USE OR REPRODUCTION OF THE CONTENTS OF THIS DOCUMENT IS PERMITTED WITHOUT THE EXPRESS WRITTEN PERMISSION OF EAGLE WINDOW & DOOR.  
 TITLE: AUXILIARY FRAME CLADDING W/ SCREW BOSS  
 FINISH: EAGLE'S STD. COLORS  
 MATL: 6063 T-6 ALUMINUM OR EQUIVALENT  
 DFT: AWW SCALE: 2=1  
 DCN: 0683 DRWG: A554

NO	DESCRIPTION	DFT	DOC	DATE	DATE: 3/28/2002	C	01 OF 03
01	ADDED/CHG'D DIM. & TOLERANCE	TWN	0778	4/4/2003			

NOTE: 1. UNLESS OTHERWISE SPECIFIED, ALL DIMENSIONS SHOWN ARE IN INCHES AND ALL TOLERANCES ARE TO BE: DEC.  $\pm .005$ ; FRAC.  $\pm 1/64$ ; ANGLES  $\pm 1/2^\circ$ .  
 2. UNLESS OTHERWISE SPECIFIED, WALL THICKNESS IS  $.055$ .  
 3. UNLESS OTHERWISE SPECIFIED, BREAK ALL CORNERS  $.015$  RADIUS.

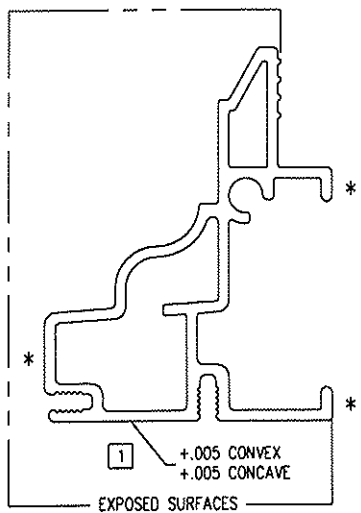
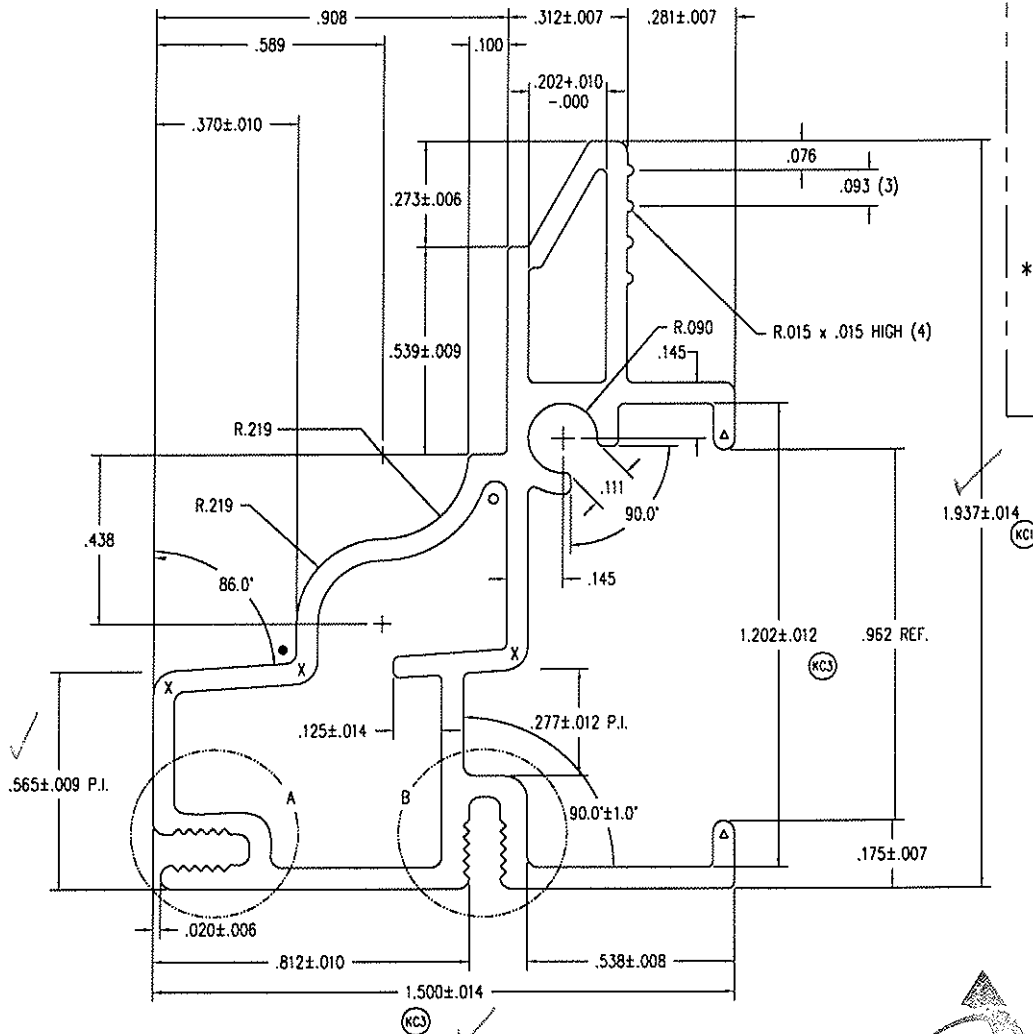

\* = PERPENDICULAR WITHIN 1.0' TO FLAT SURFACE

- R .028 (12)
- R .031 (3)
- X R .062 (5)
- △ FULL RAD.(2)



Test sample complies with these details. Deviations are noted.

Report# 80184  
 Date 2/10/08 Tech JPK

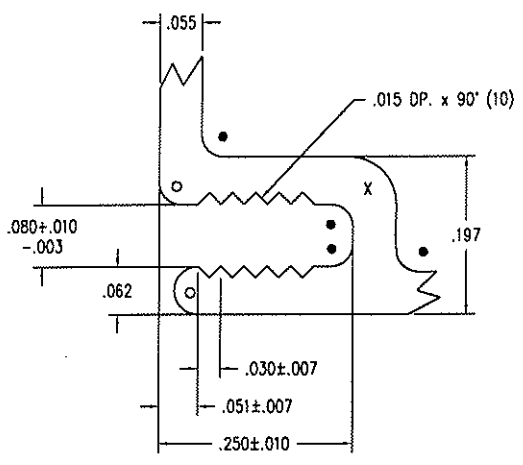

DETAIL "A"

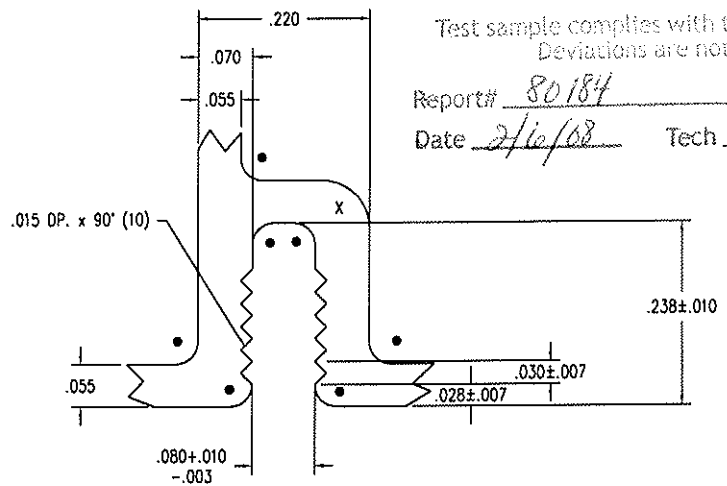

DETAIL "B"

THIS DRAWING AND ITS CONTENTS ARE THE PROPERTY OF EAGLE WINDOW & DOOR. NO USE OR REPRODUCTION OF THE CONTENTS OF THIS DOCUMENT IS PERMITTED WITHOUT THE EXPRESS WRITTEN PERMISSION OF EAGLE WINDOW & DOOR.	
TITLE: DH AUXILIARY FRAME CLADDING (W/ SCREW BOSS)	
FINISH: EAGLE'S STD. COLORS	
MATERIAL: 6063 T-6 ALUMINUM	
DFT: AWW	SCALE: 2=1
DCN: 0683	DRWG: A555

NO	DESCRIPTION	DFT	DOC	DATE	DATE:	C
01	ADDED/CHG'D DIM. & TOLERANCE	TWN	0778	4/4/03	3/28/02	01 OF 03

- NOTE: 1. UNLESS OTHERWISE SPECIFIED, ALL DIMENSIONS SHOWN ARE IN INCHES AND ALL TOLERANCES ARE TO BE: DEC. ±.005; FRAC. ±1/64; ANGLES ±1/2°.
2. VERTICAL SECONDARY STOPS WILL RUN THROUGH, HORIZONTAL SECONDARY STOPS WILL BUT UP TO THE VERTICAL SECONDARY STOP.
3. CAUX VERTICAL STOPS L = FRAME - 2.625  
 CAUX HORIZONTAL STOPS L = FRAME - 3.281  
 WAUX VERTICAL STOP L = FRAME - 2.625  
 WAUX HORIZONTAL STOP L = FRAME - 3.281

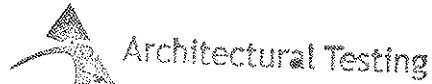

Test sample complies with these details.  
 Deviations are noted.

Report# 80184  
 Date 2/6/08 Tech gpk

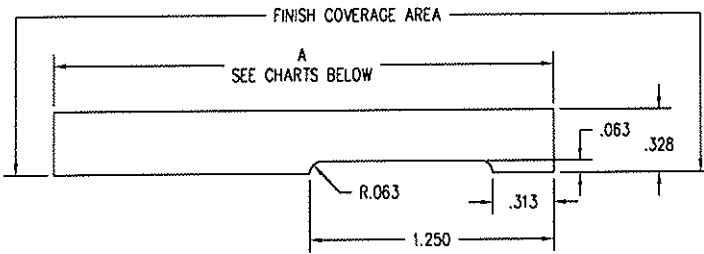
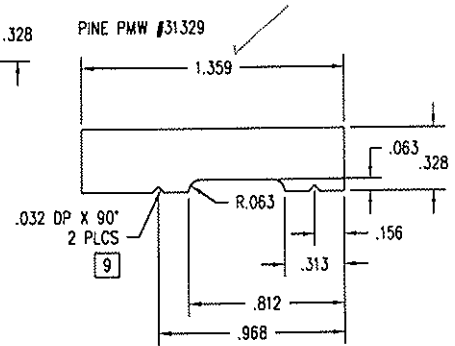
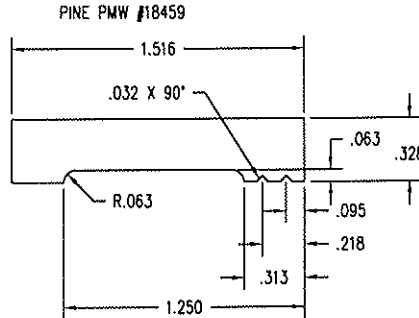
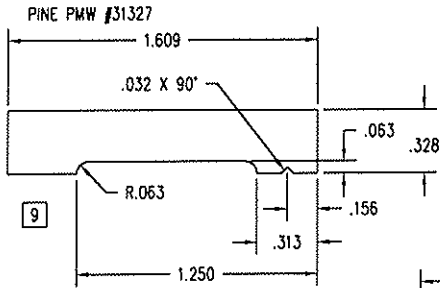

GLASS THICKNESS RANGE millimeters / inches	CLAD AUXILIARY A DIMENSION
2.20mm to 3.81mm .087" to .150"	2.250"
3.82mm to 6.15mm .151" to .242"	2.156"
6.16mm to 8.56mm .243" to .337"	2.062"
8.57mm to 10.95mm .338" to .431"	1.969"
10.96mm to 13.34mm .432" to .525"	1.875"
13.35mm to 15.72mm .526" to .619"	1.781"
15.73mm to 18.09mm .620" to .712"	1.688"
18.10mm to 20.02mm .713" to .788"	1.609"
20.03mm to 22.43mm .789" to .883"	1.516"
22.44mm to 24.44mm .884" to .962"	1.438"
24.45mm to 26.04mm .963" to 1.025"	1.359"
26.05mm to 28.42mm 1.026" to 1.119"	1.281"
28.43mm to 30.31mm 1.120" to 1.193"	1.172"

GLASS THICKNESS RANGE millimeters / inches	EXTERIOR GLAZED A DIMENSION
2.20mm to 3.35mm .087" to .132"	2.438"
3.36mm to 5.70mm .133" to .224"	2.344"
5.71mm to 8.07mm .225" to .318"	2.250"
8.08mm to 10.52mm .319" to .414"	2.156"
10.53mm to 12.83mm .415" to .505"	2.062"
12.84mm to 15.24mm .506" to .600"	1.969"
15.25mm to 17.63mm .601" to .694"	1.875"
17.64mm to 19.99mm .695" to .787"	1.781"
20.00mm to 22.41mm .788" to .882"	1.688"
22.42mm to 24.77mm .883" to .975"	1.609"
24.78mm to 26.92mm .976" to 1.060"	1.516"
26.93mm to 28.71mm 1.061" to 1.130"	1.438"
28.72mm to 30.31mm 1.131" to 1.193"	1.359"

GLASS THICKNESS RANGE millimeters / inches	WOOD AUXILIARY A DIMENSION
2.20mm to 4.77mm .087" to .188"	2.531"
4.78mm to 7.11mm .189" to .280"	2.438"
7.12mm to 9.53mm .281" to .375"	2.344"
9.54mm to 11.88mm .376" to .468"	2.250"
11.89mm to 14.30mm .469" to .563"	2.156"
14.31mm to 16.64mm .564" to .655"	2.062"
16.65mm to 19mm .656" to .750"	1.969"
19.01mm to 21.46mm .751" to .844"	1.875"
21.47mm to 23.80mm .845" to .937"	1.781"
23.81mm to 26.19mm .938" to 1.031"	1.688"
26.20mm to 28.58mm 1.032" to 1.110"	1.609"
28.59mm to 30.30mm 1.111" to 1.193"	1.516"

THIS DRAWING AND ITS CONTENTS ARE THE PROPERTY OF EAGLE WINDOW & DOOR, INC. NO USE OR REPRODUCTION OF THE CONTENTS OF THIS DOCUMENT IS PERMITTED WITHOUT THE EXPRESS WRITTEN PERMISSION OF EAGLE WINDOW & DOOR.

TITLE: SECONDARY STOP  
 AUXILIARY UNITS

FINISH:

NO	DESCRIPTION	DFT	DOC	DATE	DATE: 2/27/1992	C 01 OF 01
11	STOPS TO GLASS THICK. RANGE	ROA	1118	08/01/07	MATL: EAGLE'S STD. WOOD SPECIES	
10	ADDED 7/8" GLASS, NEW STOP	ROA	1118	07/02/07		
09	CHANGED PROFILES	TWN	1057	10/30/06	DFT: CDE	SCALE: 1=1
08	REMOVED COPED INFORMATION	TWN	0910	04/20/05	DCN: 0229	DRWG: 2038

NOTE: 1. UNLESS OTHERWISE SPECIFIED, ALL DIMENSIONS SHOWN ARE IN INCHES AND ALL TOLERANCES ARE TO BE: DEC. ±.005; FRAC. ±1/64; ANGLES ±1/2°.

PRODUCT	GLASS	A
(PRE '96 & NG) CLAD CASEMENT & AWNING	5/8"	.469
(PRE '96 & NG) CLAD CASEMENT PICTURE	3/4"	.469
CLAD PIANO HINGE CASEMENT	5/8"	.469
CLAD PIANO HINGE CASEMENT (3056 & ABOVE)	3/4"	.469
CLAD RADIUS CASEMENT	5/8" & 3/4"	.469
(PRE '96 & NG) CLAD DOUBLE / SINGLE HUNG	5/8"	.469
(PRE '96 & NG) CLAD DOUBLE HUNG PICTURE	5/8"	.469
CLAD DOUBLE HUNG TRANSOM	5/8"	.469
CLAD DOUBLE HUNG REPLACEMENT SASH	5/8"	.469
ALL CLAD (NON-RADIUS) AUXILIARY (0-15 SQ. FT.)	3/4"	.469
ALL CLAD (NON-RADIUS) AUXILIARY (15+ SQ. FT.)	1"	.469
CLAD SLIDING WINDOW	5/8"	.469
CLAD INSWING / OUTSWING FRENCH DOOR	3/4"	.469
CLAD FRENCH DOOR TRANSOM	3/4"	.469
CLAD PATIO / FRENCH SLIDING DOOR	3/4"	.469
(PRE '98) WOOD CASEMENT & AWNING	3/4"	.680
(PRE '98) WOOD CASEMENT PICTURE	3/4"	.680
(NG) WOOD CASEMENT & AWNING	5/8"	.469
(NG) WOOD CASEMENT PICTURE	5/8" & 3/4"	.469
WOOD PIANO HINGE CASEMENT	5/8"	.469
WOOD PIANO HINGE CASEMENT (3056 & ABOVE)	3/4"	.469
(PRE '96 & NG) WOOD DOUBLE / SINGLE HUNG	5/8"	.469
(PRE '96 & NG) WOOD DOUBLE HUNG PICTURE	5/8"	.469
WOOD SLIDING WINDOW	5/8"	.469
WOOD DOUBLE HUNG TRANSOM	5/8"	.469
WOOD DOUBLE HUNG REPLACEMENT SASH	5/8"	.469
WOOD (NON-RADIUS) AUXILIARY (0-15 SQ. FT.)	3/4"	.469
WOOD (NON-RADIUS) AUXILIARY (15+ SQ. FT.)	1"	.469
WOOD INSWING / OUTSWING FRENCH DOOR	3/4"	.469
WOOD FRENCH DOOR TRANSOM	3/4"	.469
WOOD PATIO / FRENCH SLIDING DOOR	3/4"	.469
CLAD & WOOD PATIO/FR. SLIDING DOOR (BLIND GLASS)	1"	.406
ALL CLAD AND WOOD WINDOWS AND DOORS EXCEPT AUXILIARY UNITS WHICH ALWAYS USES	SINGLE GLAZED H. MSTR MONO	.680



Test sample complies with these details.  
Deviations are noted.

Report# 80184  
Date 2/6/08 Tech GPK

PANEL STOPS	
PRODUCT	A
WOOD OUTSWING SIDELITE	.469
WOOD OUTSWING TRANSOM	.469
WOOD INSWING SIDELITE	.469
WOOD INSWING TRANSOM	.469
CLAD DHG PICTURE	.406

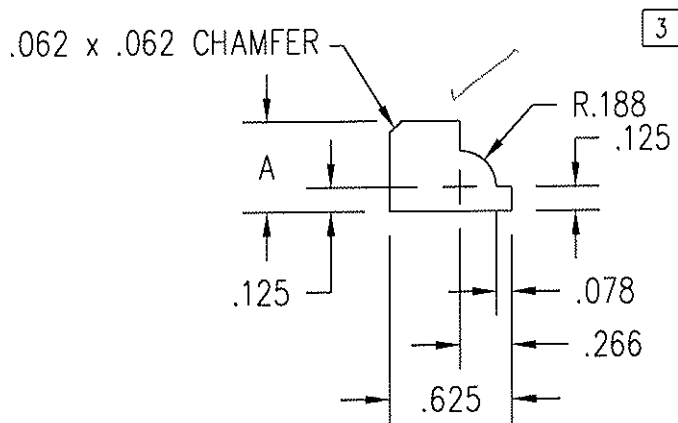

THIS DRAWING AND ITS CONTENTS ARE THE PROPERTY OF EAGLE WINDOW & DOOR. NO USE OR REPRODUCTION OF THE CONTENTS OF THIS DOCUMENT IS PERMITTED WITHOUT THE EXPRESS WRITTEN PERMISSION OF EAGLE WINDOW & DOOR.  
TITLE: COLONIAL GLAZING STOP  
FINISH:

04	ADDED CDHG PICT TO CHART	KJS	0881	3/6/07	MATL:	EAGLE STD WOOD OFFERINGS
03	ADDED SIZE FOR IMPACT GLAZING	TWN	0972	9/1/05	DFT:	JMH SCALE: 1=1
02	CHG'D CLAD PANEL STOP "A" DIM	JH	0794	6/30/05	DCN:	0650 DRWG: 220J
01	ADDED KYLER BLIND SIZE	TWN	0910	4/19/05	DATE:	5/29/2002 A 01 OF 03
NO	DESCRIPTION	DFT	DOC	DATE		