

**AAMA/WDMA/CSA 101/LS.2/A440-08
TEST REPORT**

Rendered to:

EAGLE WINDOW & DOOR, INC.

**SERIES/MODEL: Monumental Double Hung 40100
PRODUCT TYPE: Aluminum Clad Wood Double Hung**

Title	Summary of Results
Primary Product Designator	LC-PG35-H 1219 x 3048 (48 x 120)
Design Pressure	1680 Pa (35.0 psf)
Operating Force (in motion)	150 N (33.7 lbf)
Air Infiltration	0.21 L/s/m ² (0.04 cfm/ft ²)
Water Penetration Resistance Test Pressure	400 Pa (8.25 psf)
Uniform Load Structural Test Pressure	±2520 Pa (52.5 psf)
Forced Entry Resistance	Grade

Test Completion Date: 05/31/07

Reference must be made to Report No. 73120.02-201-44, dated 12/05/08 for complete test specimen description and data.

AAMA/WDMA/CSA 101/I.S.2/A440-08 TEST REPORT

Rendered to:

EAGLE WINDOW & DOOR, INC.
2045 Kerper Boulevard
Dubuque, Iowa 52001

Report No.: 73120.02-201-44
Test Dates: 05/31/07
Original Report Date: 06/29/07
Revised Report Date: 12/05/08
Expiration Date: 05/31/11

Project Summary: Architectural Testing, Inc. was contracted by Eagle Window & Door, Inc. perform testing on a Series/Model Monumental Double Hung 40100, Aluminum Clad Wood Double Hung window. The sample tested successfully met the performance requirements for a LC-PG35 1219 x 3048 (48 x 120) rating. Test specimen description and results are reported herein.

Test Specification: The test specimen was evaluated in accordance with AAMA/WDMA/CSA 101/I.S.2/A440-08, *NAFS - North American Fenestration Standard/Specification for Windows, Doors, and Skylights*.

Test Specimen Description:

Series/Model: Monumental Double Hung 40100

Product Type: Aluminum Clad Wood Double Hung window

Overall Size: 1219 mm (48") wide by 3048 mm (120") high

Bottom Sash Size: 1124 mm (44-1/4") wide by 1534 mm (60-3/8") high

Top Sash Size: 1124 mm (44-1/4") wide by 1534 mm (60-3/8") high

Screen Size: 1146 mm (45-1/8") wide by 2997 mm (118") high

Daylight Opening Size: 1035 mm (40-3/4") wide by 1397 mm (55") high

Overall Area: 3.17 m² (40 ft²)

Test Specimen Description: (Continued)

Finish: Exterior cladding was painted white, interior wood was natural.

Frame Construction: Head frame corners were coped, butted, sealed with silicone, and secured with three 11 mm (7/16") by 44 mm (1-3/4") long staples per corner. Sill frame corners were coped, butted, sealed with a corner gasket and silicone, and secured with two #8 by 44 mm (1-3/4") screws. Aluminum cladding was slip-fit over wood members, miter-cut at head corners and secured with a corner key and two #6 by 11 mm (7/16") screws per corner. Sill corners were coped, butted sealed with a corner gasket and silicone, and secured with a #7 by 32 mm (1-1/4") screw and a #6 by 11 mm (7/16") screw.

Sash Construction: The lower sash and upper sash, top rail and stiles consisted of molded pine sections, the lower sash meeting rail was LVL. Upper sash corners were mortise-and-tenon construction and secured with glue and one 5 mm (3/16") by 38 mm (1-1/2") staple per corner. Aluminum cladding was slip-fit over wood members, upper sash corners were miter-cut, sealed with butyl and secured with a corner key and two #4 by 13 mm (1/2") screws per corner. Lower sash corners were mortise-and-tenon construction; meeting rail corners were secured with glue and two 5 mm (3/16") by 38 mm (1-1/2") staples per corner; bottom rail corners were secured with glue and one #8 by 57 mm (2-1/4") screw per corner. Aluminum cladding was slip-fit over wood members, corners were coped, butted and sealed with butyl.

Screen Construction: The screen was comprised of roll-formed aluminum with plastic corner keys. Fiberglass screen cloth was attached with a vinyl spline.

Glazing Details: The sash were glazed with nominal 19 mm (3/4") insulating glass comprised of two nominal 4 mm (5/32") annealed sheets separated by a desiccant-filled stainless steel spacer system. The glass was set from the interior against InstantGlaze II silicone sealant and secured with wood glazing beads set on the interior, secured with 25 mm (1") brad nails spaced 152 mm to 203 mm (6" to 8") on center.

Weatherstripping:

<u>Description</u>	<u>Quantity</u>	<u>Location</u>
Hollow vinyl bulb	1 Row	Lower sash bottom rail; upper sash meeting rail
Foam filled bulb	1 Row	Head jamb and side jambs
Wool pile	2	Side jambs at check rail

Test Specimen Description: (Continued)

Hardware:

<u>Description</u>	<u>Quantity</u>	<u>Location</u>
Vinyl jamb liner with block-and-tackle balance	2	Jamb pockets
Sweep locks and keepers with integrated tilt latches	2	203 mm (8") from sash corner
Stainless steel tilt pins	4	Bottom corners of stiles

Installation: The window was installed within a wood test frame with installation clips that were secured to the window with two #8 by 16 mm (5/8") screws and to the buck on the interior and exterior with two #8 by 38 mm (1-1/2") screws that were spaced 610 mm (24") from corners on side jambs, with 51 mm (2") roofing nails 203 mm (8") on center through flange. The unit was sealed to the buck with silicone.

Test Results: The temperature during testing was 21°C (70°F). The results are tabulated as follows:

<u>Paragraph</u>	<u>Title of Test - Test Method</u>	<u>Results</u>	<u>Allowed</u>
5.3.1	Operating Force per ASTM E 2068		
	Open		
	Initiate motion	145 N (32.7 lbf)	--
	Maintain motion	133 N (30.0 lbf)	180 N (40.0 lbf)
	Close		
	Initiate motion	71 N (16.0 lbf)	--
	Maintain motion	150 N (33.7 lbf)	180 N (40.0 lbf)
	Latches		
	Lock	13 N (3.0 lbf)	100 N (22.5 lbf)
	Unlock	13 N (3.0 lbf)	100 N (22.5 lbf)
5.3.2.1	Air Leakage Resistance per ASTM E 283		
	75 Pa (1.6 psf)	0.35 L/s/m ² (0.07 cfm/ft ²)	1.5 L/s/m ² (0.3 cfm/ft ² max.)
	300 Pa (6.2 psf)	0.97 L/s/m ² (0.19 cfm/ft ²)	-- --

Note #1: The tested specimen meets (or exceeds) the performance levels specified in AAMA/WDMA/CSA 101/I.S.2/A440-08 for air leakage resistance.

Test Results: (Continued)

<u>Paragraph</u>	<u>Title of Test - Test Method</u>	<u>Results</u>	<u>Allowed</u>
5.3.3.2	Water Penetration Resistance per ASTM E 547 and E 331		See Note #2
5.3.4.2	Uniform Load Deflection per ASTM E 330		See Note #2
5.3.4.3	Uniform Load Structural per ASTM E 330		See Note #2
<i>Note #2: The client opted to start at a pressure higher than the minimum required. Those results are listed under "Optional Performance".</i>			
5.3.5	Forced Entry Resistance per ASTM F 588 Type: A	Grade: 10	
	Disassembly Test	No entry	No entry
	Tests A1 through A5; A7	No entry	No entry
	Sash/Panel Manipulation Test	No entry	No entry
	Lock Hardware Manipulation Test	No entry	No entry
5.3.6.3	Deglazing Test		
	In operating direction - 320 N (70 lbf)		
	Upper sash-top rail	1.5 mm (0.06")	11.4 mm (0.45")
	Upper sash-meeting rail	1.0 mm (0.04")	11.4 mm (0.45")
	Lower sash-meeting rail	1.3 mm (0.05")	11.4 mm (0.45")
	Lower sash-bottom rail	1.3 mm (0.05")	11.4 mm (0.45")
	In remaining direction - 230 N (50 lbf)		
	Upper sash-left stile	0.8 mm (0.03")	11.4 mm (0.45")
	Upper sash-right stile	1.0 mm (0.04")	11.4 mm (0.45")
	Lower sash-left stile	0.8 mm (0.03")	11.4 mm (0.45")
	Lower sash-right stile	0.8 mm (0.03")	11.4 mm (0.45")

Optional Performance

4.3.2.1	Water Penetration Resistance per ASTM E 547 and E 331 (with and without insect screen) 400 Pa (8.25 psf)	No leakage	No leakage
---------	--	------------	------------

Test Results: (Continued)

<u>Paragraph</u>	<u>Title of Test - Test Method</u>	<u>Results</u>	<u>Allowed</u>
------------------	------------------------------------	----------------	----------------

Optional Performance (Continued)

4.3.2.1	Uniform Load Deflection per ASTM E 330 (Positive deflections were taken on the meeting rail; negative deflections were taken on the sash stile) (Loads were held for 60 seconds)		
	1680 Pa (35.0 psf) (positive)	5.01 mm (0.20")	See Note #3
	1680 Pa (35.0 psf) (negative)	21.8 mm (0.86")	See Note #3

***Note #3:** The deflections reported are not limited by AAMA/WDMA/CSA 101/I.S.2/A440-08 for this product designation. The deflection data is recorded in this report for special code compliance and information only.*

4.3.2.1	Uniform Load Structural per ASTM E 330 (Permanent sets were taken on the sash stile) (Loads were held for 10 seconds)		
	2520 Pa (52.5 psf) (positive)	2.3 mm (0.09")	6.1 mm (0.24") max.
	2520 Pa (52.5 psf) (negative)	1.3 mm (0.05")	6.1 mm (0.24") max.

Tape and film were used to seal against air leakage during structural testing. In our opinion, the tape and film did not influence the results of the test.

Drawing Reference: The test specimen drawings have been reviewed by Architectural Testing and are representative of the test specimen reported herein.

List of Official Observers:

<u>Name</u>	<u>Company</u>
Thad McKinley	Eagle Window & Door, Inc.
Joe Cogan	Eagle Window & Door, Inc.
Karl A. Lips-Eakins	Architectural Testing, Inc.
Eric J. Schoenthaler	Architectural Testing, Inc.

Detailed drawings, data sheets, representative samples of test specimens, a copy of this report, or other pertinent project documentation will be retained by Architectural Testing, Inc. for a period of four years from the original test date. At the end of this retention period, such materials shall be discarded without notice and the service life of this report will expire.

Results obtained are tested values and were secured by using the designated test methods. No conclusions of any kind regarding the adequacy or inadequacy of the glass in the test specimen can be made. This report does not constitute certification of this product nor an opinion or endorsement by this laboratory. It is the exclusive property of the client so named herein and relates only to the specimens tested. This report may not be reproduced, except in full, without the written approval of Architectural Testing, Inc.

For ARCHITECTURAL TESTING, INC.

Eric J. Schoenthaler
Project Manager

Daniel A. Johnson
Director - Regional Operations

EJS:mb

Attachments (pages): This report is complete only when all attachments listed are included.

- Appendix-A: Alteration Addendum (1)
- Appendix B: WDMA Submittal Forms (2)
- Appendix-B: Drawings (41)

Revision Log

<u>Rev. #</u>	<u>Date</u>	<u>Page(s)</u>	<u>Revision(s)</u>
0	06/27/07	N/A	Original report issue. Report and drawings forwarded to AMS for Hallmark Certification.
1	07/06/07	2	Corrected glazing sealant in glazing paragraph. Report and drawings forwarded to AMS for Hallmark Certification.
2	12/05/08	All	Test Report results conducted prior to 2008 standard being published; report is as compared to 2008 standard. Report and drawings forwarded to AMS for Hallmark Certification.

Appendix A:
Alteration Addendum

Note: No alterations were required,

Appendix B:
WDMA Submittal Forms



WDMA HALLMARK CERTIFICATION PROGRAM REPORT SUBMISSION FORM

THIS FORM IS TO BE COMPLETED BY THE MANUFACTURER AND SUBMITTED TO AMS PRIOR TO OR ALONG WITH SUBMISSION OF EACH NEW OR REVISED TEST REPORT FOR CERTIFICATION TO THE HALLMARK PROGRAM. ANY QUESTIONS PLEASE CONTACT AMS AT 315-646-2234 OR staff@amscert.com.

Manufacturer: Eagle Window and Door, Inc.

Contact: Todd Bergstrom

Plant Location(s):
(list all plants where product is made)
2045 Kerper Blvd. Dubuque, IA 52004-1072

Phone: 563-556-2270

Test Report #: 73120.02-201-44-R1

Email: tbergstrom@eaglewindow.com

Product Relationship:

Extension of currently certified product? yes no n/a Recertification New (check one)

If yes, what CCL # ? 099-H-684.01

Difference from Certified Product: Report re-written to A440.08 standard.

Is this a Gateway Test ? yes no n/a

Does this report require a Gateway Report # ? yes no n/a Report #: _____

Impact Report:

If this is not an impact report check here:

AWS Report # _____

Test Plan # ? yes no n/a _____

Installation Instructions submitted ? yes no n/a

Certification to Florida:

If this will not be submitted to Florida check here:

AMS to Input to Database yes no n/a

Manufacturer to input yes no n/a



WDMA HALLMARK CERTIFICATION PROGRAM REPORT SUBMISSION FORM

Product Name: T7 Talon Monumental Double Hung Vent
(as to be listed on CCL)

Product Type: Hung Window – Vertical Sliding

Additional Manufacturer ID #: _____

n/a

<u>Hallmark CCL</u>	<u>Standard</u>	<u>Rating</u>
<input type="checkbox"/>	ANSI/AAMA/NWWDA 101/I.S. 2 97	_____
<input type="checkbox"/>	101/I.S.2/NAFS-02	_____
<input type="checkbox"/>	AAMA/WDMA/CSA/101/I.S.2/A440-05	_____
<input checked="" type="checkbox"/>	AAMA/WDMA/CSA/101/I.S.2/A440-08	LC-PG35-H +35 / -35
<input type="checkbox"/>	ASTM E 1996 99 / E1886-97	_____
<input type="checkbox"/>	ASTM E 1996 01 / E1886-97	_____
<input type="checkbox"/>	ASTM E 1996 02 / E1886-02	_____
<input type="checkbox"/>	ASTM E 1996 03 / E1886-02	_____
<input type="checkbox"/>	ASTM E 1996 04 / E1886-04	_____
<input type="checkbox"/>	ASTM E 1996 05 / E1886-05	_____
<input type="checkbox"/>	ASTM E330 02	_____
<input type="checkbox"/>	ANSI A250.13-03	_____
<input type="checkbox"/>	TAS 201-94	_____
<input type="checkbox"/>	TAS 202-94	_____
<input type="checkbox"/>	TAS 203-94	_____
<input type="checkbox"/>	Other:	_____

Appendix C

Drawings

1. (36) 2" ROOFING NAILS THROUGH NAIL FIN INTO BUCK SPACES 3 1/2" FROM EACH END AND 6" ON CENTER THEREAFTER.

Technical Drawing
 Title: *Window Installation Detail*
 Top and Bottom Views of the details.
 Dimensions are noted.

Report# *23120*
 Date *5/29-6/1/07* Tech *T6*

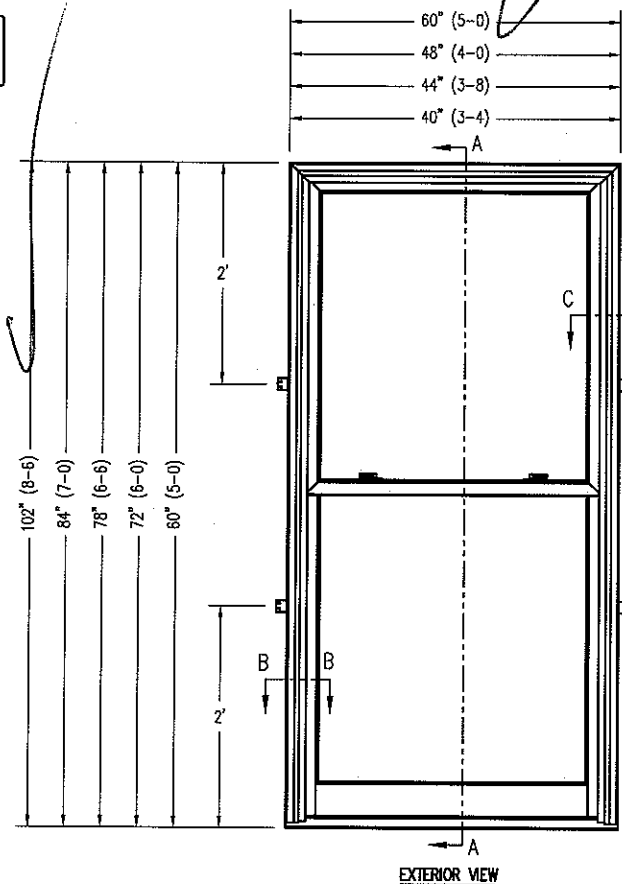
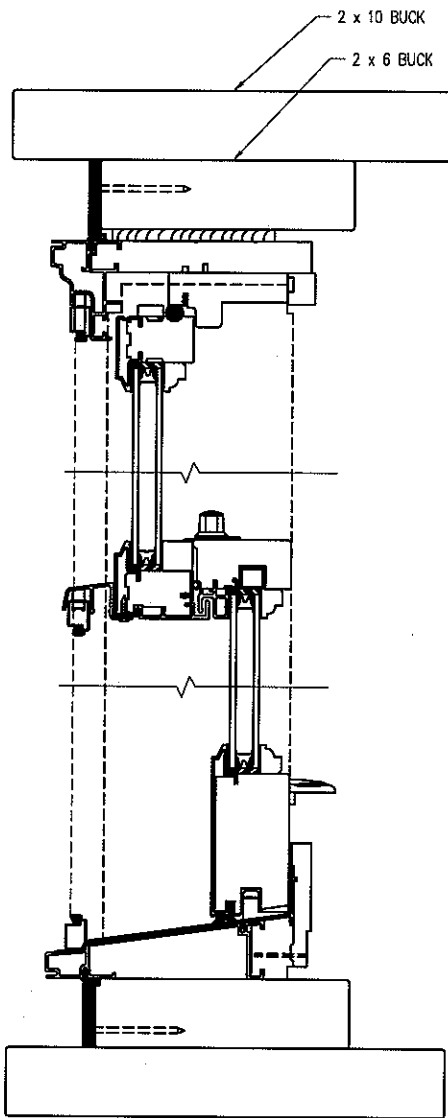
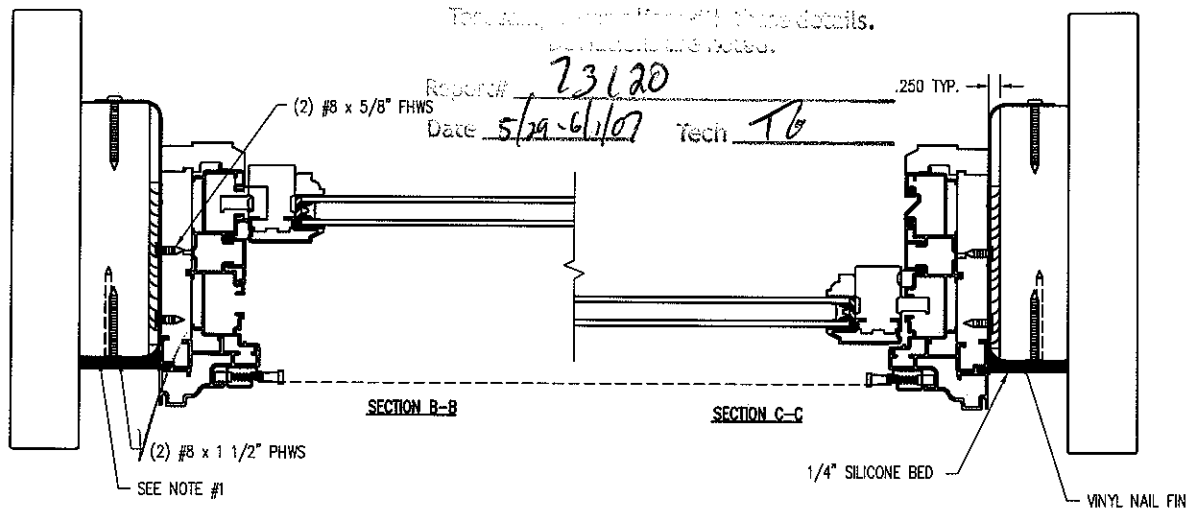

THIS DRAWING AND ITS CONTENTS ARE THE PROPERTY OF EAGLE WINDOW & DOOR. NO USE OR REPRODUCTION OF THE CONTENTS OF THIS DOCUMENT IS PERMITTED WITHOUT THE EXPRESS WRITTEN PERMISSION OF EAGLE WINDOW & DOOR.

TITLE:	CDHV
TITLE:	INSTALLATION DETAIL
FINISH:	
MATL:	
DFT:	KJS
DCN:	0881
DATE:	3/19/07
SCALE:	1=4
DRWG:	0535
C	01 OF 02

NO	DESCRIPTION	DFT	DOC	DATE

1. (36) 2" ROOFING NAILS THROUGH NAIL FIN INTO BUCK SPACES 3 1/2" FROM EACH END AND 6" ON CENTER THEREAFTER.

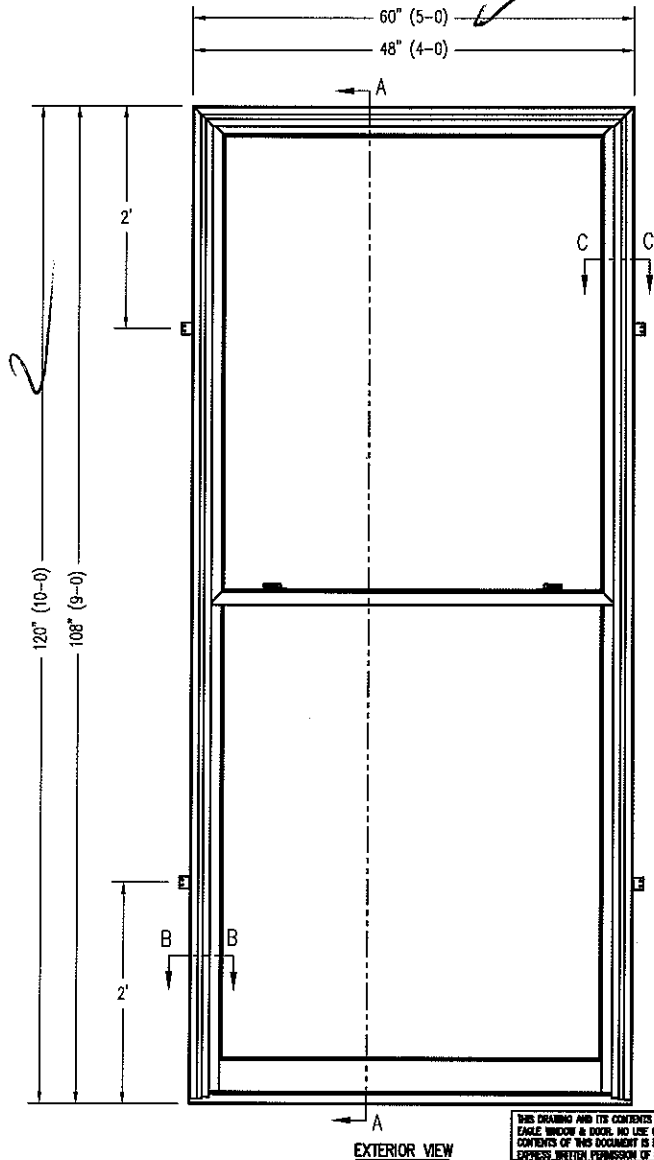
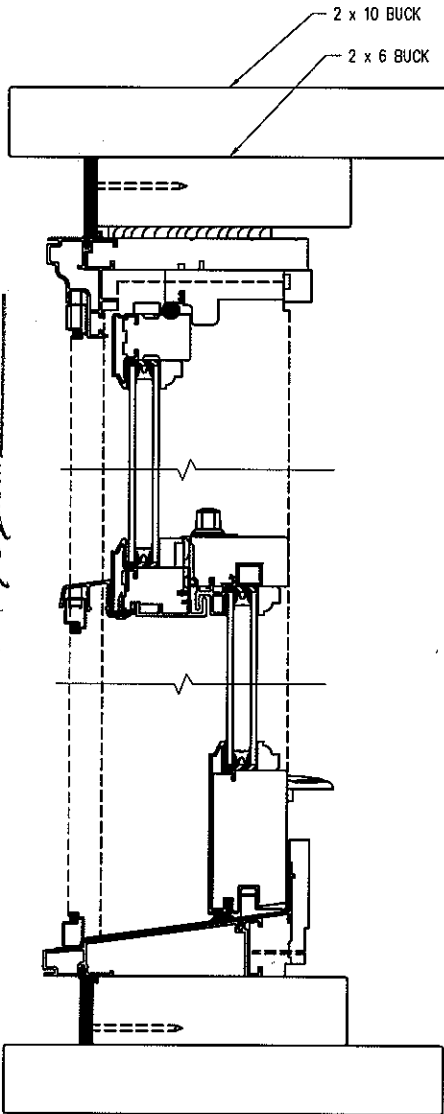
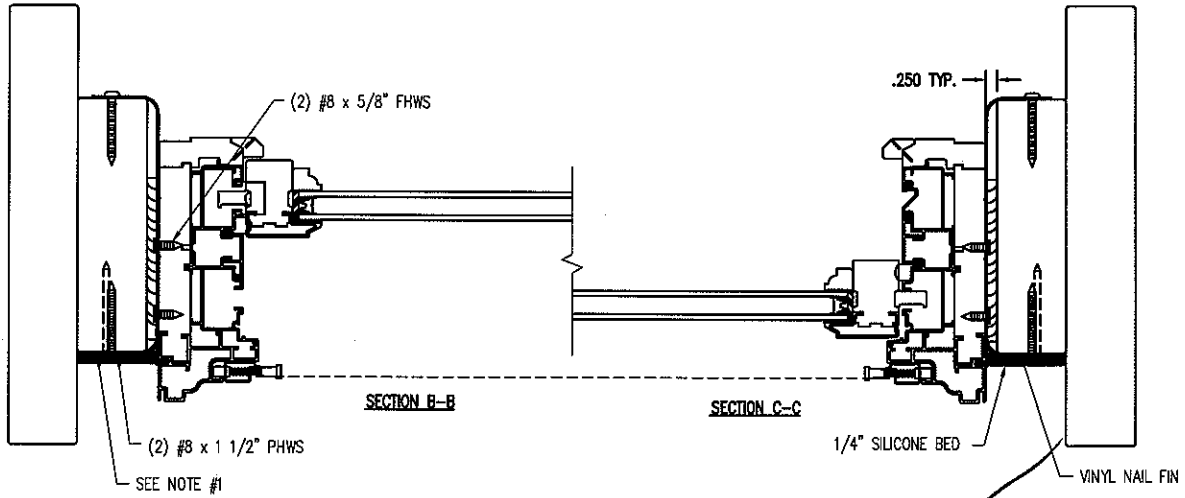

Architectural Testing

Test sample conditions may differ slightly. Deviations are noted.

Report# 73120
Date 5/29/16 Tech TC

THIS DRAWING AND ITS CONTENTS ARE THE PROPERTY OF EAGLE WINDOW & DOOR. NO USE OR REPRODUCTION OF THE CONTENTS OF THIS DOCUMENT IS PERMITTED WITHOUT THE EXPRESS WRITTEN PERMISSION OF EAGLE WINDOW & DOOR.

TITLE: CMSHV
INSTALLATION DETAIL

FINISH:

MATERIAL:

DFT: KJS SCALE: 1=4

DCN: 0881 DRWG: 0535

DATE: 3/19/07 C 02

NO	DESCRIPTION	DFT	DOC	DATE



Architectural Testing

Test sample complies with these details.
Deviations are noted.

Report# 73100
Date 5/29/07 Tech TG

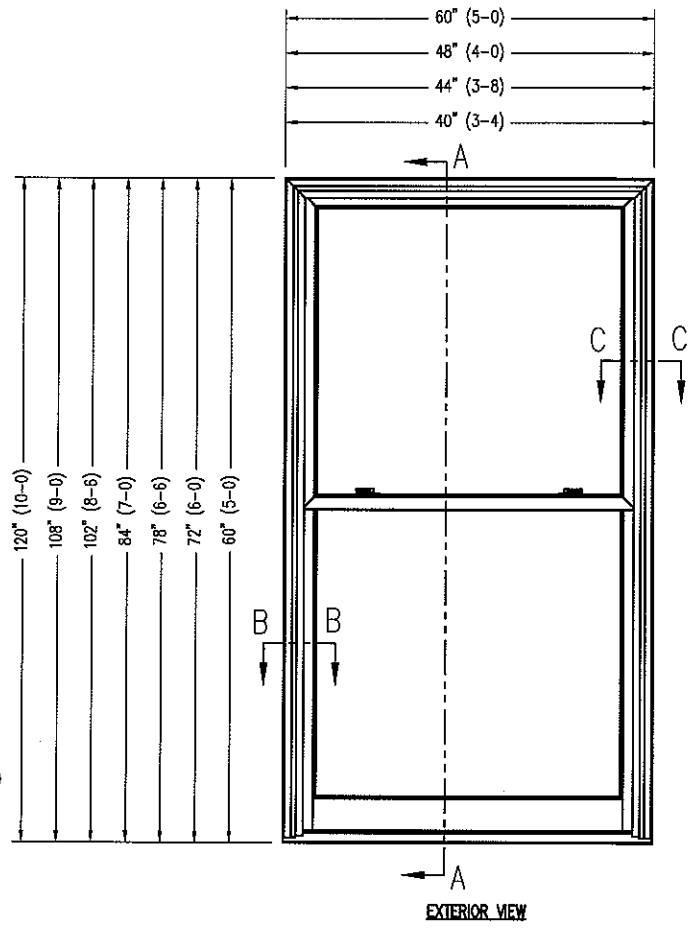
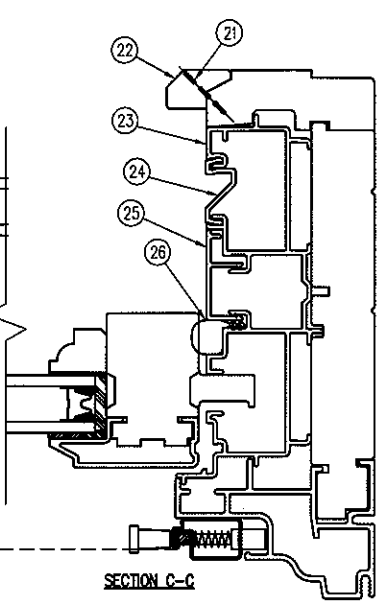
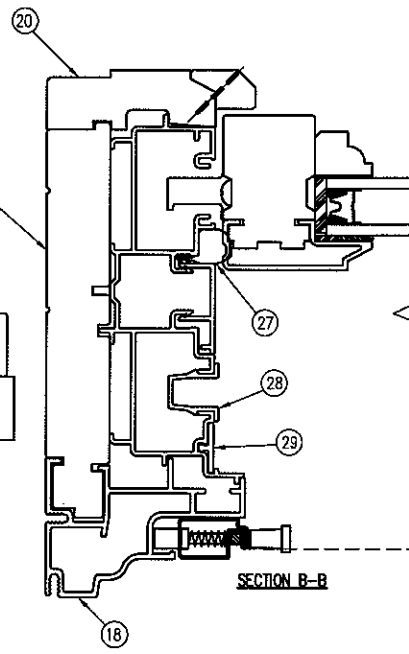
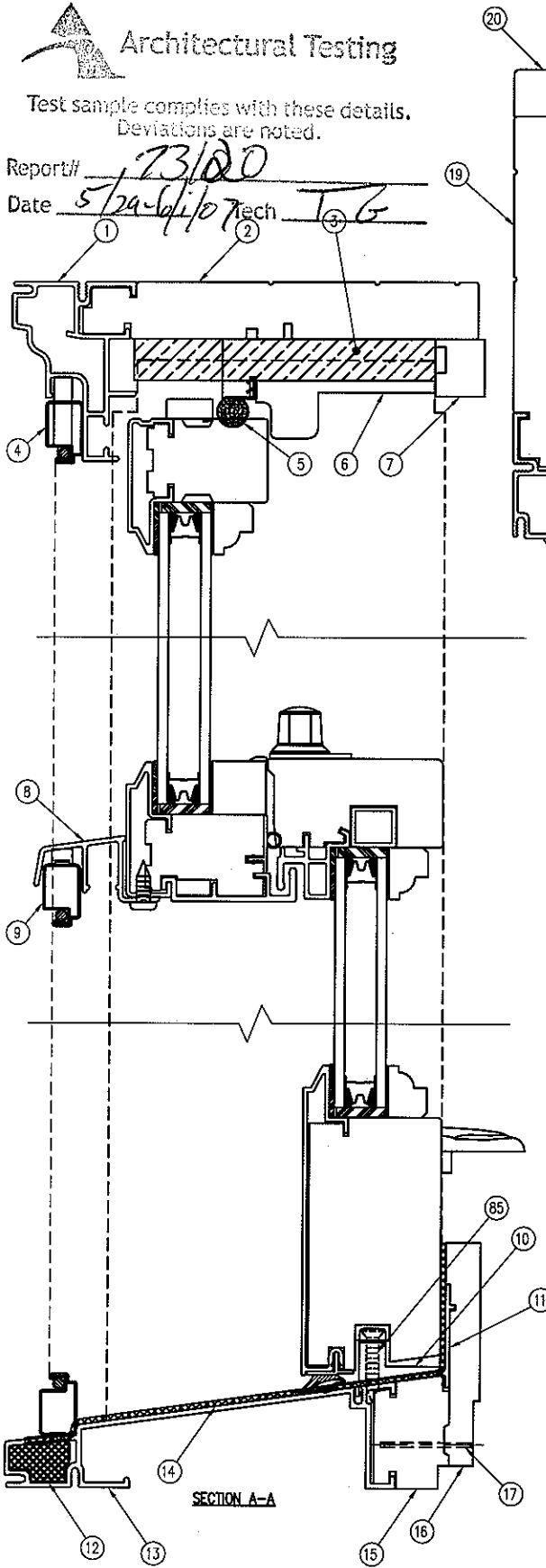

THIS DRAWING AND ITS CONTENTS ARE THE PROPERTY OF
EAGLE WINDOW & DOOR. NO USE OR REPRODUCTION OF THE
CONTENTS OF THIS DOCUMENT IS PERMITTED WITHOUT THE
EXPRESS WRITTEN PERMISSION OF EAGLE WINDOW & DOOR.

TITLE: 07 CDHV
UNIT ASSEMBLY

FINISH:

MATERIAL:

DFT: KJS SCALE: 1=2
DCN: 0881 DRWR: 0534
DATE: 3/19/07 C 01 OF 12

NOI	DESCRIPTION	DFT	DOC	DATE



Architectural Testing

Test sample complies with these details.
Deviations are noted.

Report# 73170
Date 2/29-6/10 Tech 16

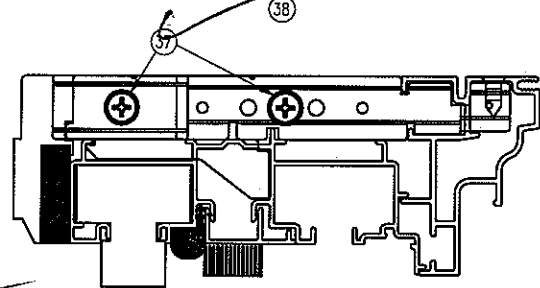
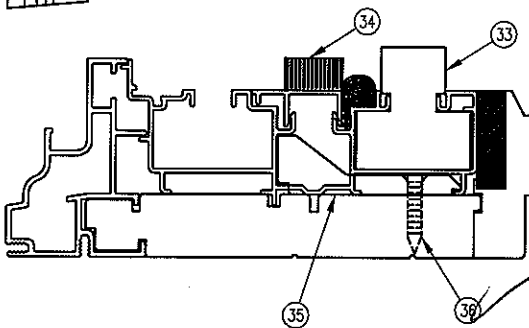
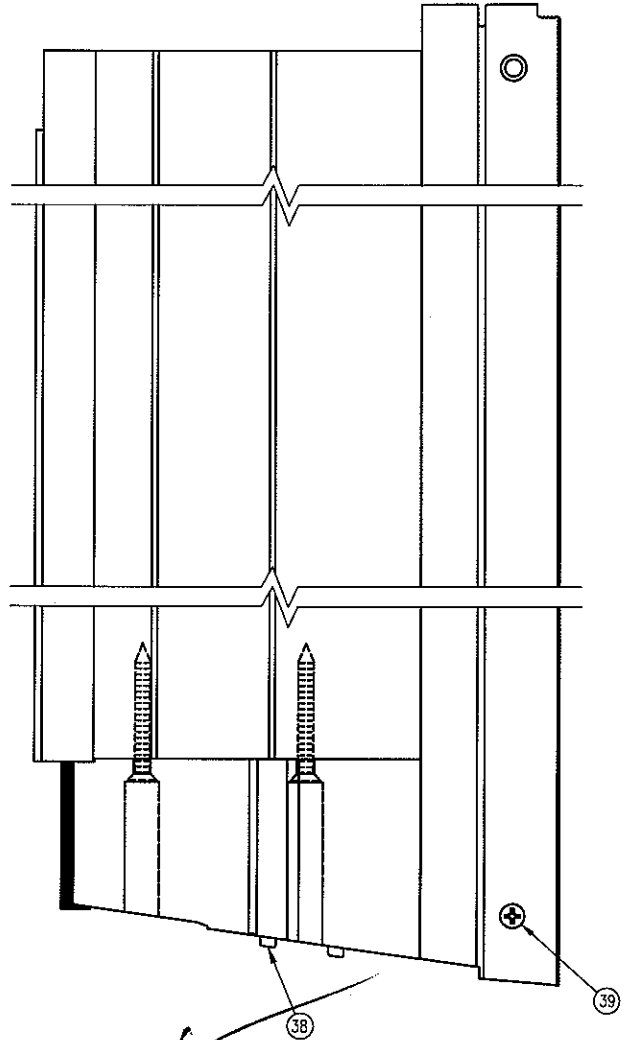
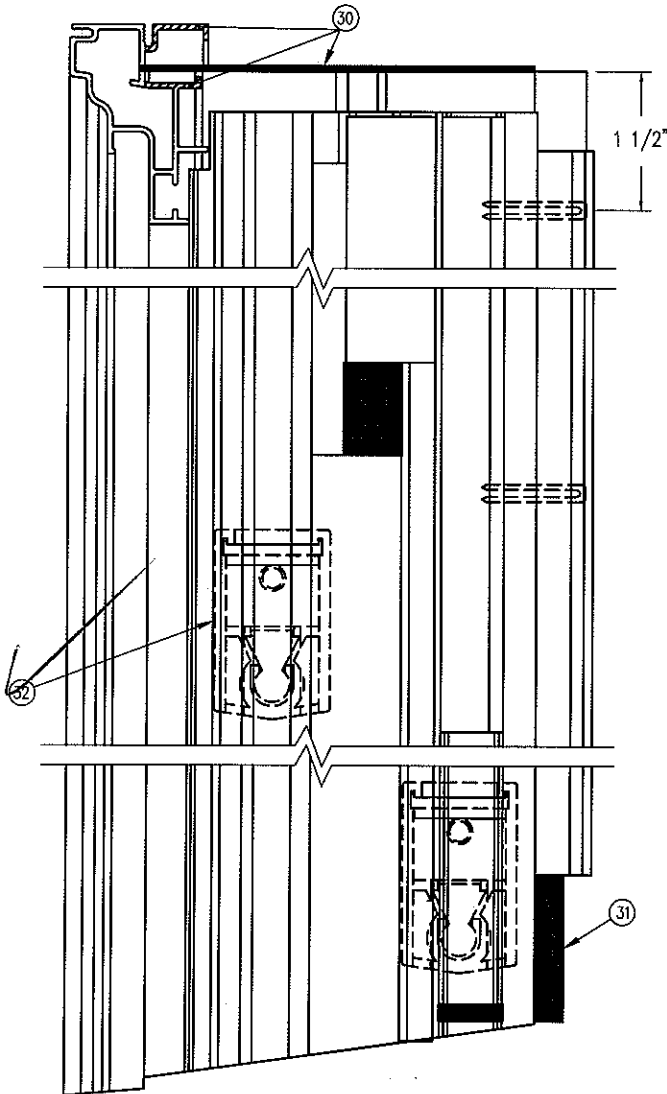
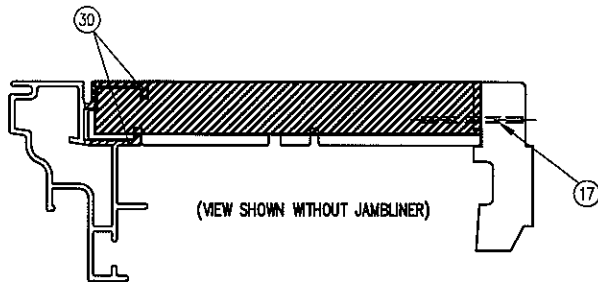

THIS DRAWING AND ITS CONTENTS ARE THE PROPERTY OF
EAGLE WINDOW & DOOR. NO USE OR REPRODUCTION OF THE
CONTENTS OF THIS DOCUMENT IS PERMITTED WITHOUT THE
EXPRESS WRITTEN PERMISSION OF EAGLE WINDOW & DOOR.

TITLE: CDHV
UNIT ASSEMBLY

FINISH:

MATL:

DFT: KJS SCALE: 1=2
DCN: 0881 DRWG: 0834

NO.	DESCRIPTION	DFT	DOC	DATE
				DATE: 3/19/07
				G 02



Architectural Testing

Test sample complies with these details.
Deviations are noted.

Report# **13120**
Date **5/22-6/10/07** Tech **TG**

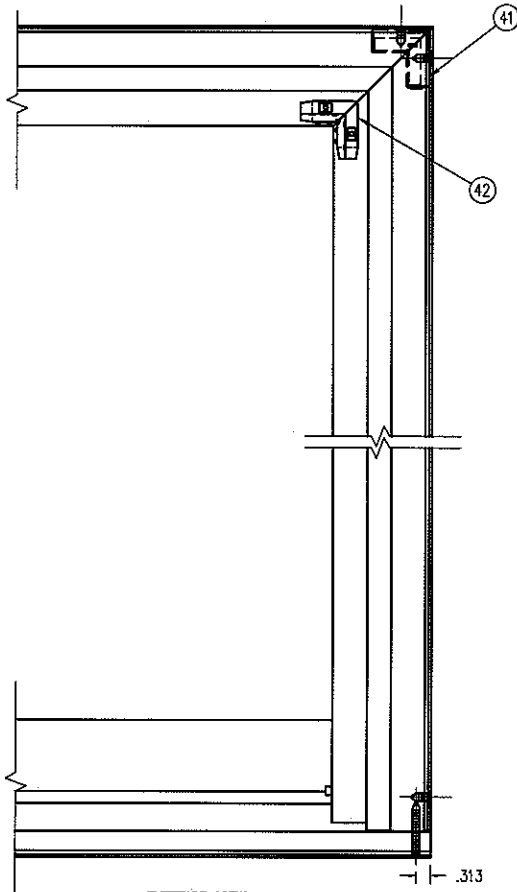
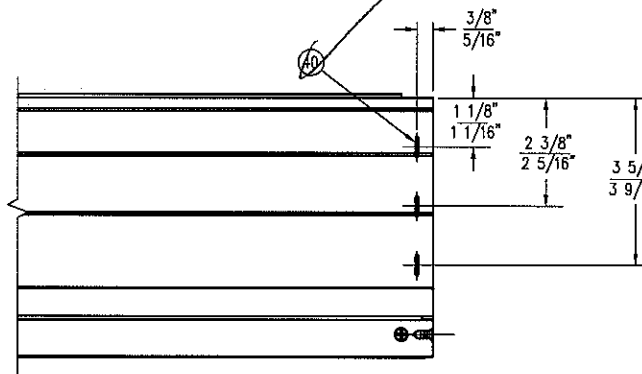

EXTERIOR VIEW

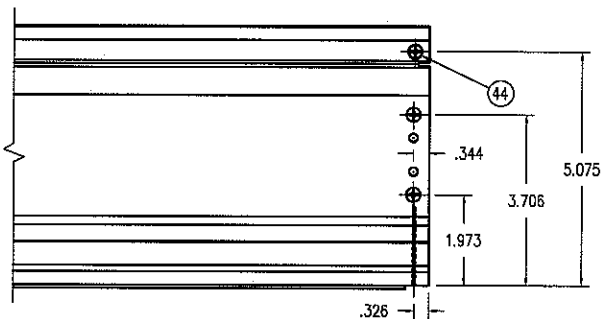
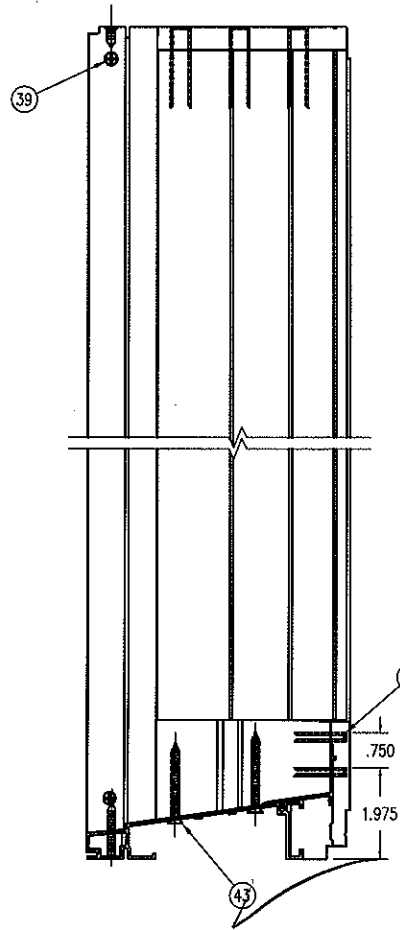

THIS DRAWING AND ITS CONTENTS ARE THE PROPERTY OF EAGLE WINDOW & DOOR. NO USE OR REPRODUCTION OF THE CONTENTS OF THIS DOCUMENT IS PERMITTED WITHOUT THE EXPRESS WRITTEN PERMISSION OF EAGLE WINDOW & DOOR.

TITLE: **CDRV**
UNIT ASSEMBLY
FINISH:
MATERIAL:

DFT: **KJS** SCALE: **1=4**
DCN: **0881** DRWG: **0534**

NOI	DESCRIPTION	DFT	DOC	DATE
				DATE: 3/19/07
				C 03



Architectural Testing

Test sample complies with these details.
Deviations are noted.

Report# 73120
Date 6/29-07 Tech JG

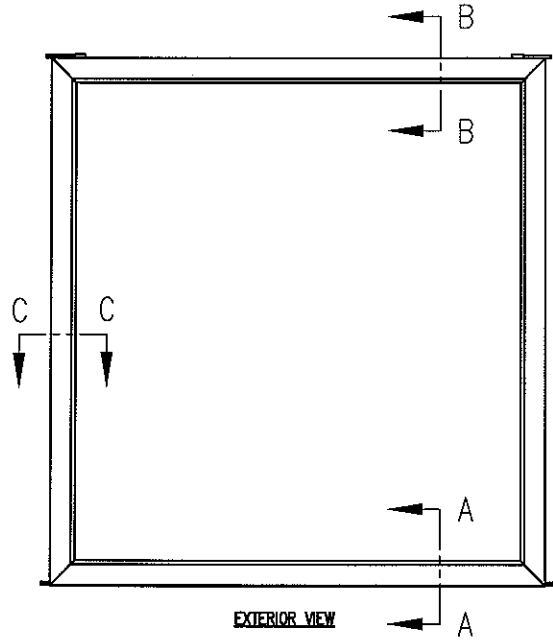
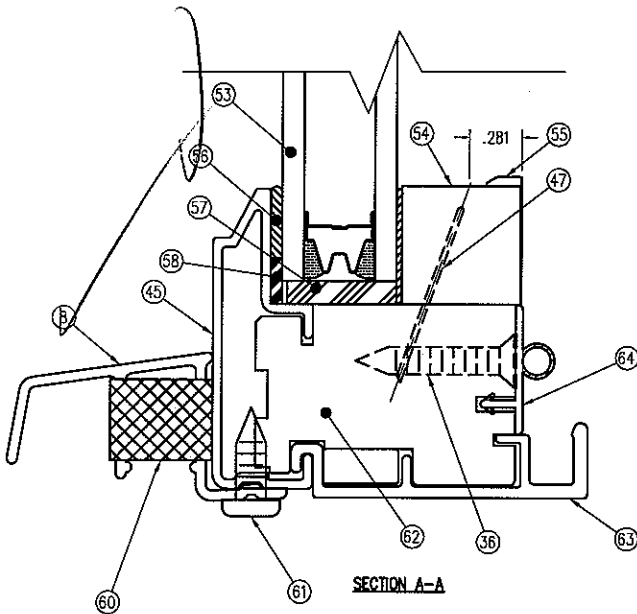
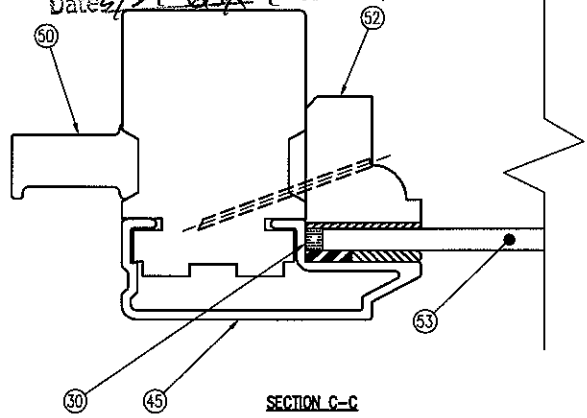
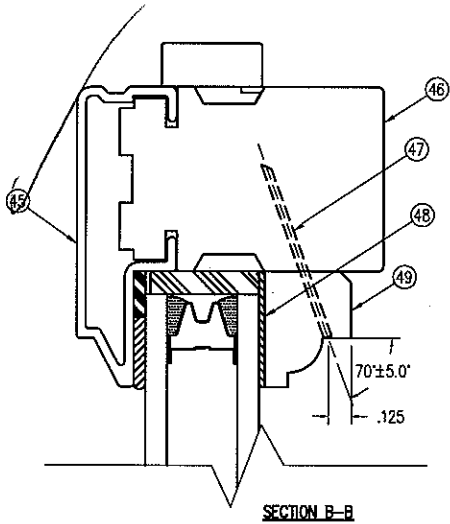

THIS DRAWING AND ITS CONTENTS ARE THE PROPERTY OF
EAGLE WINDOW & DOOR. NO USE OR REPRODUCTION OF THE
CONTENTS OF THIS DOCUMENT IS PERMITTED WITHOUT THE
EXPRESS WRITTEN PERMISSION OF EAGLE WINDOW & DOOR.

TITLE: CDHV
UPPER SASH ASSEMBLY

FINISH:

MATL:

DEF: KJS SCALE: 1=1
DCN: 0881 DRWG: 0534
DATE: 3/19/07 C 04

NOI	DESCRIPTION	DFT	DOC	DATE

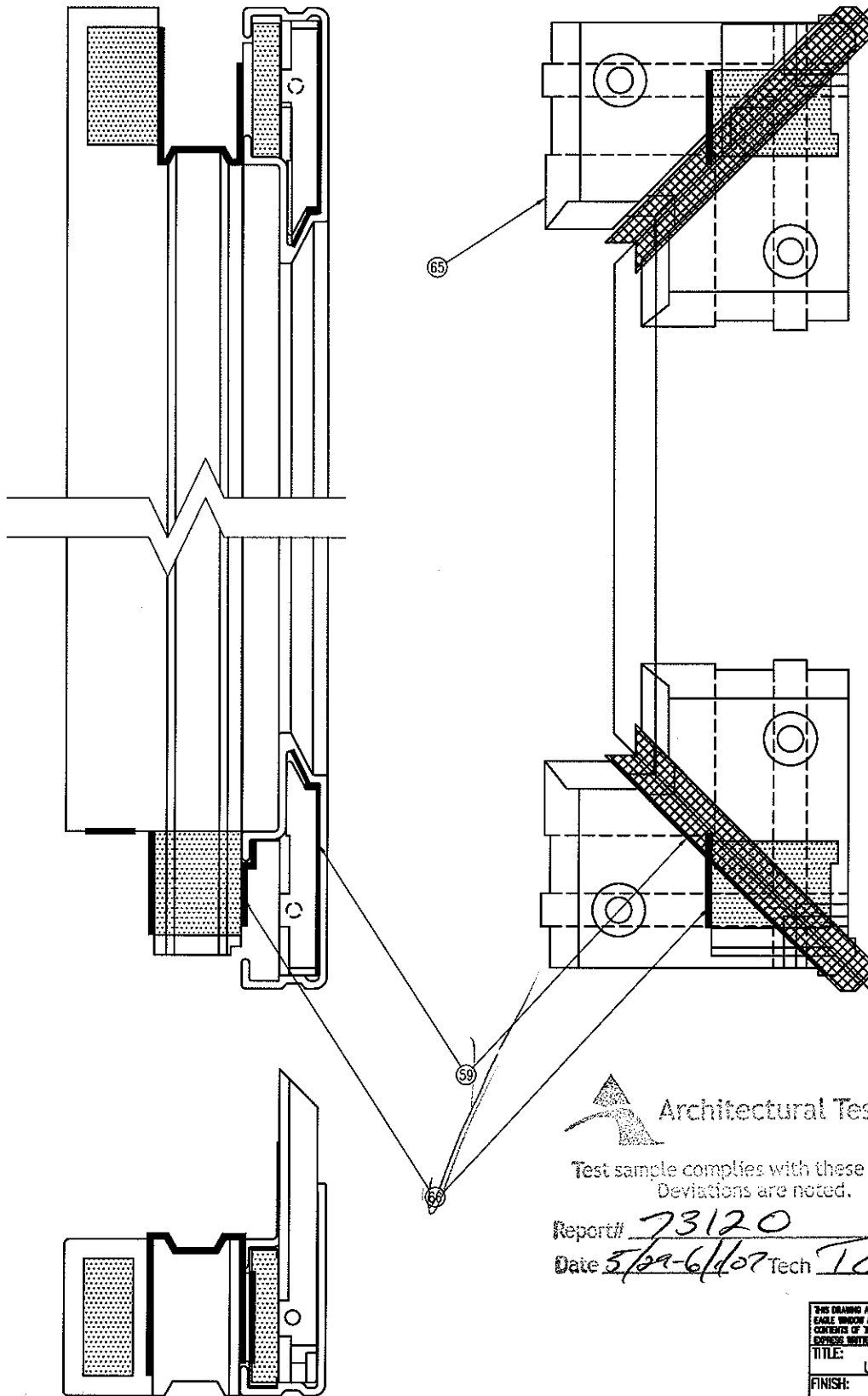

Architectural Testing

Test sample complies with these details.
Deviations are noted.

Report# 73120
Date 5/29-6/1/07 Tech TG

THIS DRAWING AND ITS CONTENTS ARE THE PROPERTY OF LEAGUE WINDOW & DOOR. NO USE OR REPRODUCTION OF THE CONTENTS OF THIS DOCUMENT IS PERMITTED WITHOUT THE EXPRESS WRITTEN PERMISSION OF LEAGUE WINDOW & DOOR.			
TITLE:		CDHV	
FINISH:		UPPER SASH ASSEMBLY	
MATERIAL:			
DFT:	KJS	SCALE:	1=1
DCN:	0881	DRWG:	0534
DATE:	3/19/07	C	05

NO.	DESCRIPTION	DFT	DOC	DATE

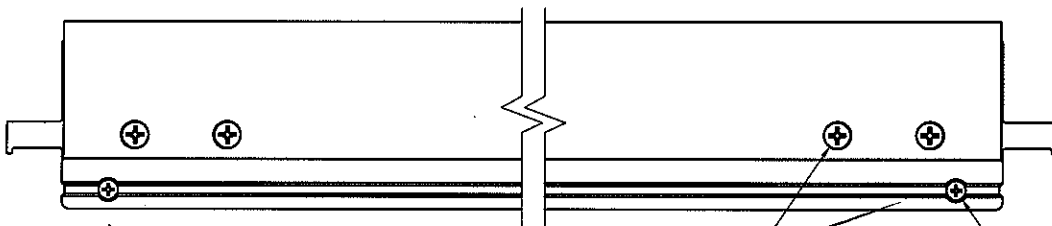
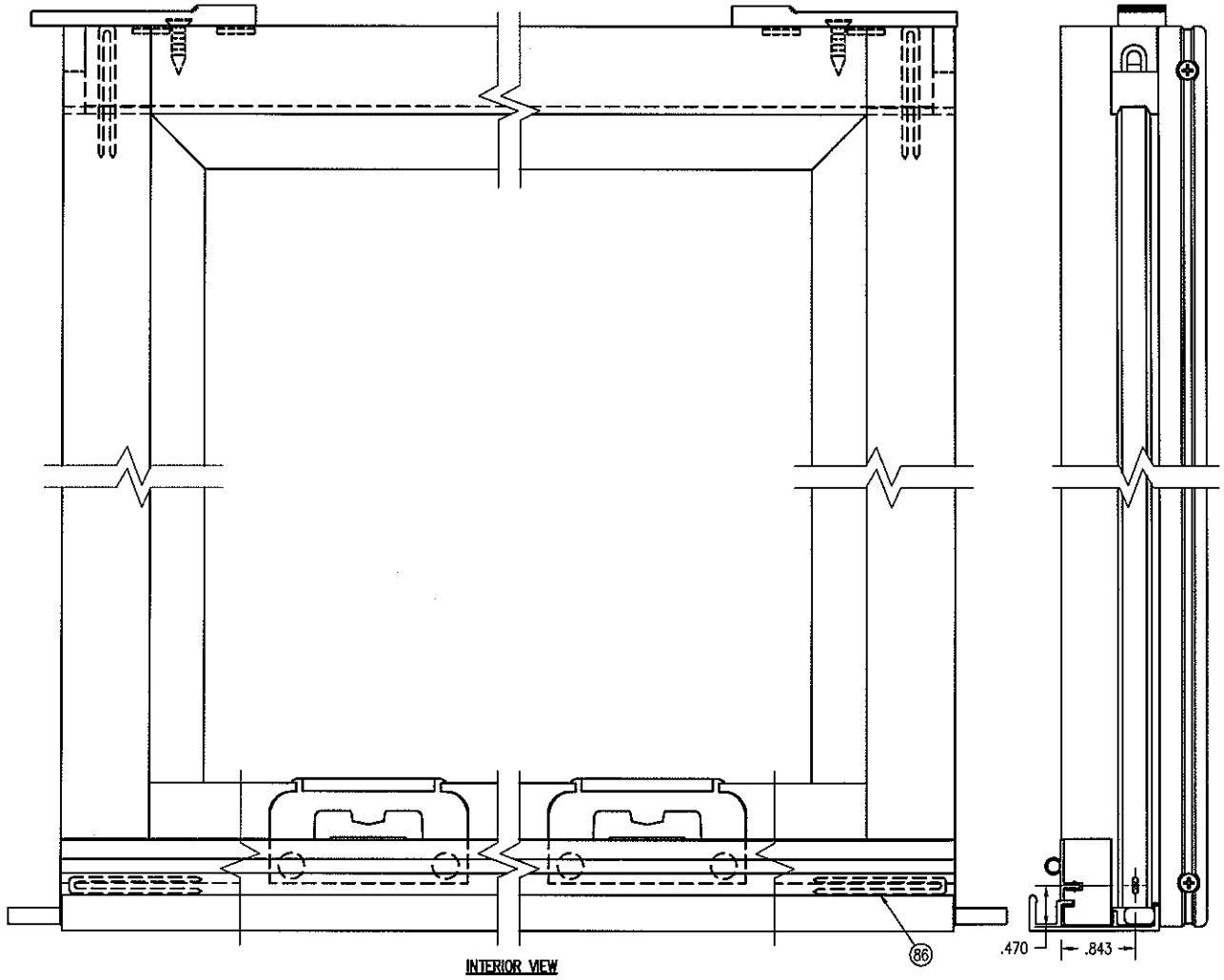
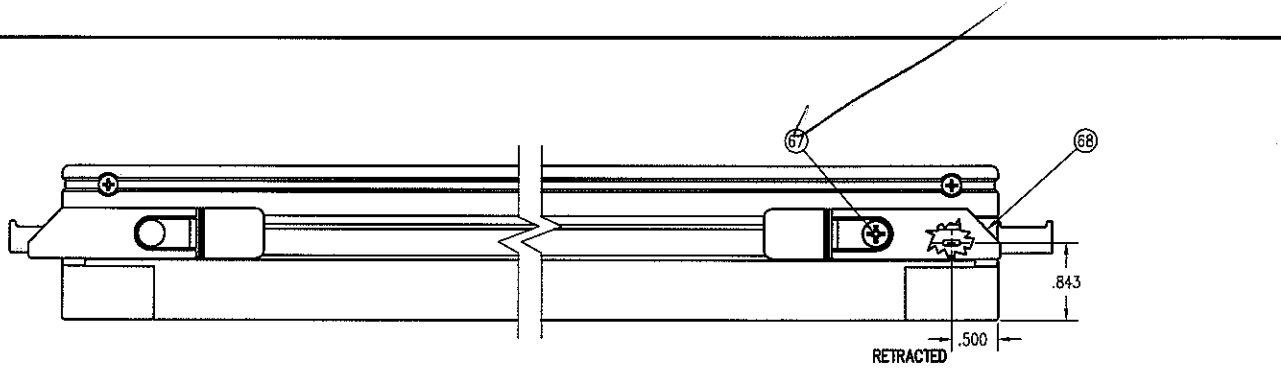

Architectural Testing

Test sample complies with these details.
Deviations are noted.

Report# 73120
Date 5/29-6/10/07 Tech TG

ALL DRAWINGS AND ITS CONTENTS ARE THE PROPERTY OF EAGLE WINDOW & DOOR. NO USE OR REPRODUCTION OF THE CONTENTS OF THIS DOCUMENT IS PERMITTED WITHOUT THE EXPRESS WRITTEN PERMISSION OF EAGLE WINDOW & DOOR.

TITLE:	CDHV		
TITLE:	UPPER SASH ASSEMBLY		
FINISH:			
MATL:			
DFT:	KJS	SCALE:	1=2
DCN:	0881	DRWG:	0534
DATE:	3/19/07	C	06

NOI	DESCRIPTION	DFT	DOC	DATE

Architectural Testing

Test sample complies with those details.
Deviations are noted.

Report# 73120
Date 5/22-6/1/07 Tech TG

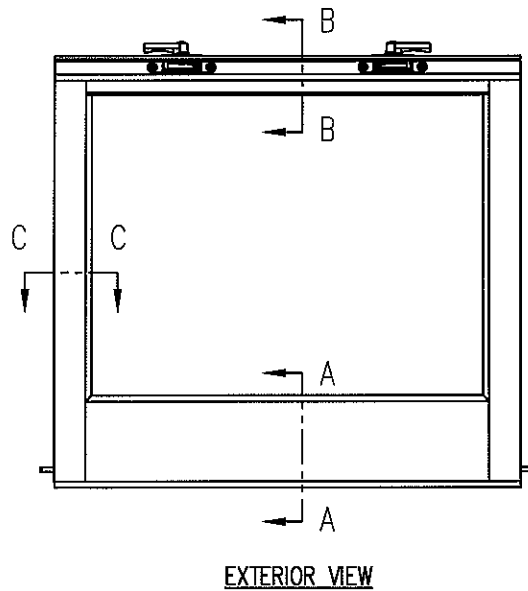
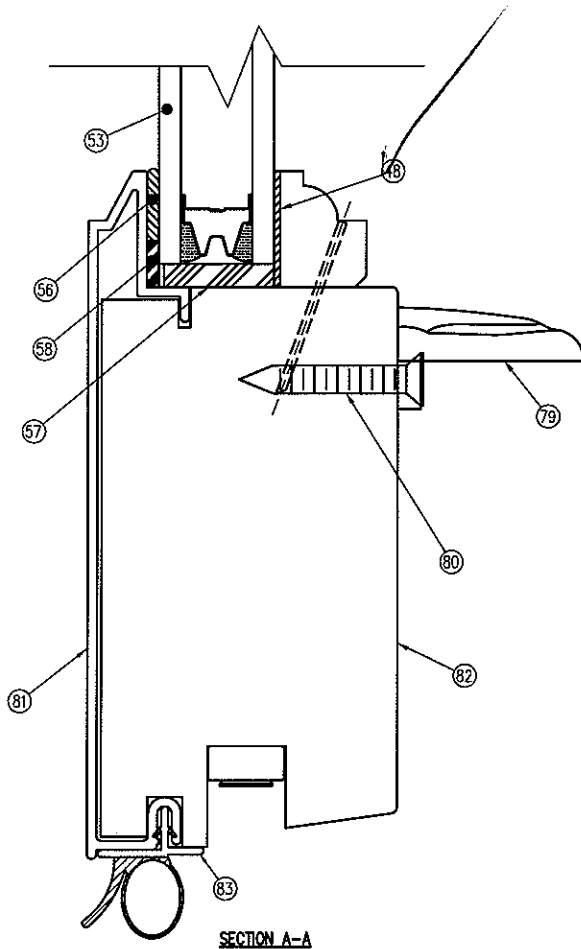
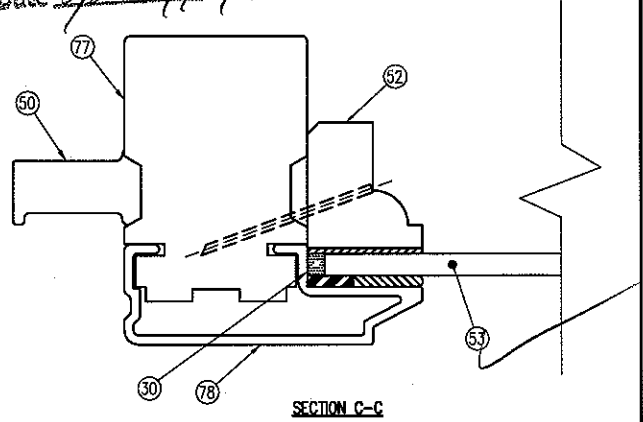
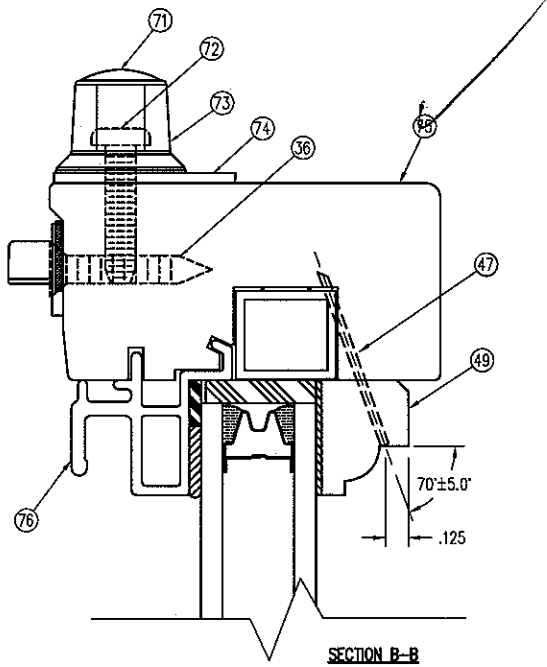

THIS DRAWING AND ITS CONTENTS ARE THE PROPERTY OF
EAGLE WINDOW & DOOR. NO USE OR REPRODUCTION OF THE
CONTENTS OF THIS DOCUMENT IS PERMITTED WITHOUT THE
EXPRESS WRITTEN PERMISSION OF EAGLE WINDOW & DOOR.

TITLE: CDHV
LOWER SASH ASSEMBLY

FINISH:

MATL:

DFT: KJS SCALE: 1=1
DCN: 0881 DRWG: 0534

NO	DESCRIPTION	DFT	DOC	DATE
				DATE: 3/19/07 C 07

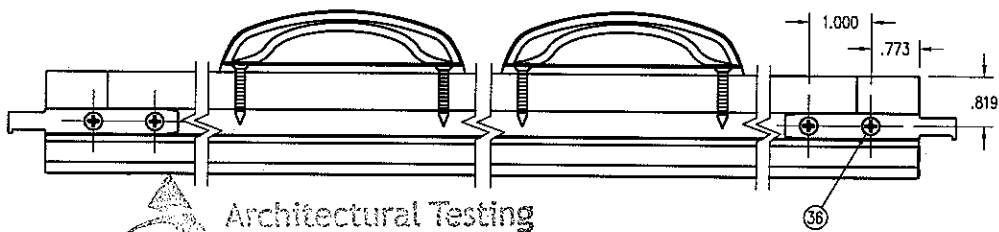
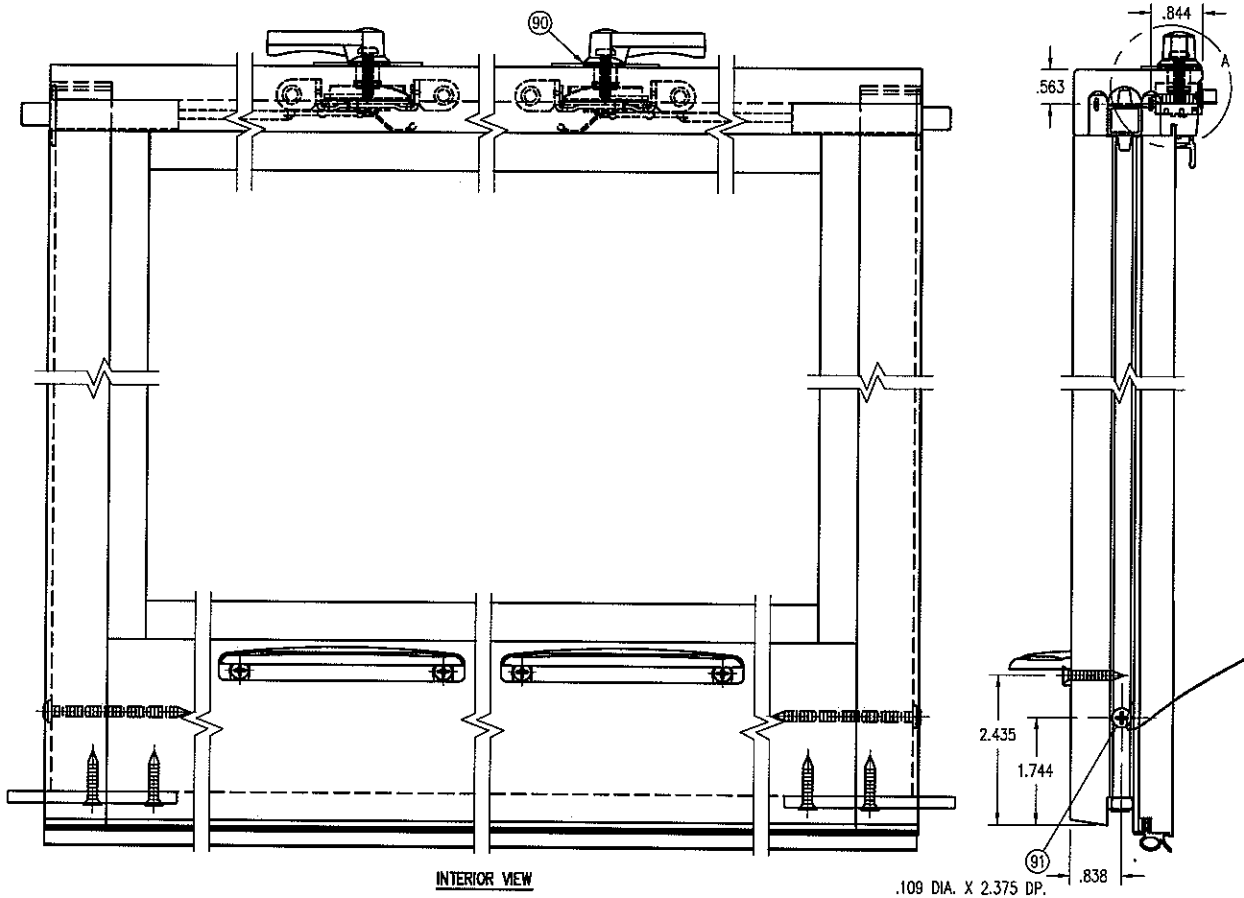
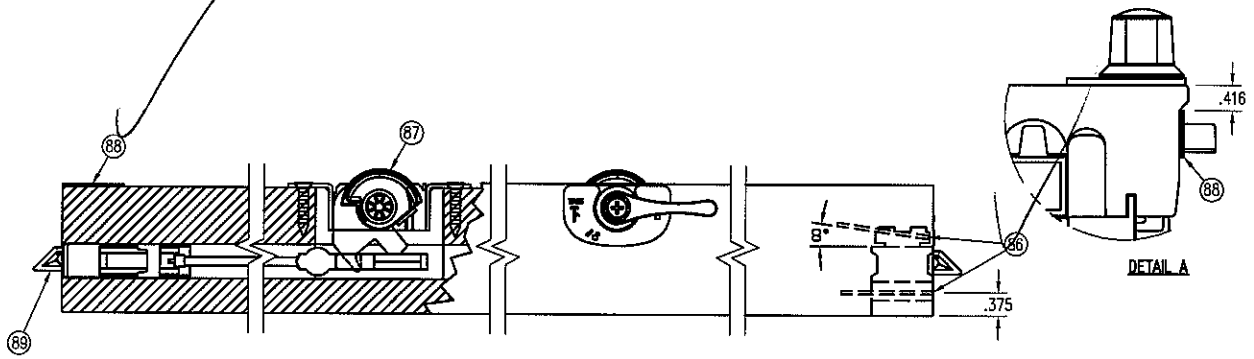

Architectural Testing

Test sample complies with these details.
Deviations are noted.

Report# 73120
Date 5/29-6/1/07 Tech TE

THIS DRAWING AND ITS CONTENTS ARE THE PROPERTY OF EAGLE WINDOW & DOOR. NO USE OR REPRODUCTION OF THE CONTENTS OF THIS DOCUMENT IS PERMITTED WITHOUT THE EXPRESS WRITTEN PERMISSION OF EAGLE WINDOW & DOOR.			
TITLE: CDHV		SCALE: 1=3	
FINISH: LOWER SASH ASSEMBLY			
MATERIAL:			
DFT: KJS	DCN: 0881	DRWG: 0534	DATE: 3/19/07
NOI		DESCRIPTION	DFT DOC DATE
			C 09



Test sample complies with these details.
Deviations are noted.

Report# 73120
Date 5/29-6/1/07 Tech TG

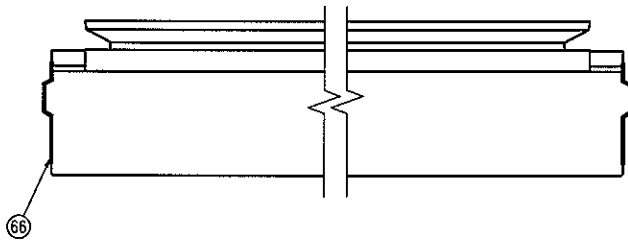
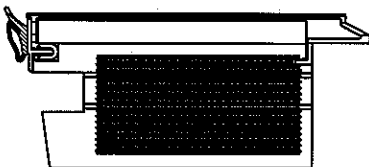
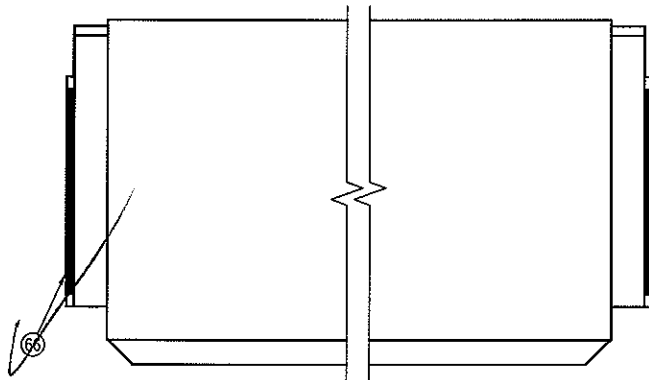
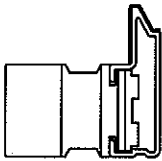
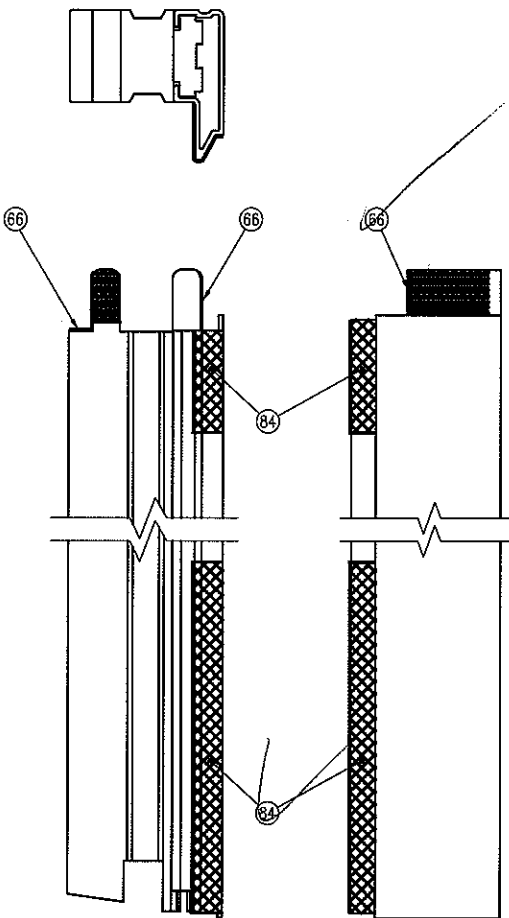

THIS DRAWING AND ITS CONTENTS ARE THE PROPERTY OF
EAGLE WINDOW & DOOR. NO USE OR REPRODUCTION OF THE
CONTENTS OF THIS DOCUMENT IS PERMITTED WITHOUT THE
EXPRESS WRITTEN PERMISSION OF EAGLE WINDOW & DOOR.

TITLE: CDHV
LOWER SASH ASSEMBLY

FINISH:

MAIL:

DFI: KJS SCALE: 1=2
DCN: 0881 DRWG: 0534

NOI	DESCRIPTION	DFT	DOC	DATE
				DATE: 3/19/07
				C 08

NO.	DWG NO.	DESCRIPTION	QUANTITY	MATERIAL	SUPPLIER
1	A514	HEAD FRAME CLADDING	1	ALUMINUM	BONNELL
2	21E9	HEAD	1	WOOD (LVL)	EAGLE WINDOW & DOOR
3	A52D	HEAD PAD	2	EPDM	CLIM-A-TECH
4	046W	SCREEN ASSEMBLY (OPT.)	1	ALUMINUM	HOMESHIELD
5	A43G	HEAD WEATHER STRIP	1	URETHANE FOAM	AMESBURY FOAMTITE
6	21YA	FRAME PARTING STOP/HEAD COVER	1	WOOD	EAGLE WINDOW & DOOR
7	212N	VENT INTERIOR HEAD STOP	1	WOOD	EAGLE WINDOW & DOOR
8	A473	HALF SCREEN RETAINER	1	ALUMINUM	BONNELL
9	046X	HALF SCREEN ASSEMBLY (OPT.)	1	ALUMINUM	HOMESHIELD
10	A732	SNUBBER	2	GLASS FILLED NYLON	LCS
11	A74H	SILL WATER DAM	1	VINYL	CLIM-A-TECH
12	A72H	FRAME PLUG	2	NYLON	LCS
13	A571	FRAME SILL COVER	1	ALUMINUM	HYDRO
14	A735	SETTING PAD	2	PVC FOAM	CLIM-A-TECH
15	20F1	THERMAL BLOCK	1	WOOD	EAGLE WINDOW & DOOR
16	20F8	SILL STOP	1	WOOD	EAGLE WINDOW & DOOR
	20FM	SILL STOP - AUX OPTION		WOOD	EAGLE WINDOW & DOOR
17	A00L	3/16" x 1 1/8" STAPLE	AS REQUIRED	GALVANIZED STEEL	ABILITY FASTENERS
18	A514	SIDE FRAME COVER	2	ALUMINUM	HYDRO
19	2134	JAMB	2	WOOD (LVL)	EAGLE WINDOW & DOOR
20	20F6	SIDE INTERIOR STOP	2	WOOD	EAGLE WINDOW & DOOR
21	A28C	5/8" BRAD HEAD FINISH NAIL - 18 GA.	AS REQUIRED	GALVANIZED STEEL	ABILITY FASTENERS
22	20FL	INTERIOR SIDE STOP (MONUMENTAL)	2	WOOD	EAGLE WINDOW & DOOR
23	A71W 01	JAMBLINER	2	VINYL	CLIM-A-TECH
	A71W 02	JAMBLINER (W/ NOTCH) (MONUMENTAL)		VINYL	CLIM-A-TECH
24	A71N	SPRING COVER	2	PVC	CLIM-A-TECH
25	A48Y	PVC SNAP IN UPPER	2	RIGID PVC	CLIM-A-TECH
	A558	WOOD VENEER SNAP IN UPPER (OPT.)		RIGID PVC	CLIM-A-TECH
26	A523	JAMB WEATHERSTRIP UPPER	2	URETHANE FOAM	SCHLEGEL
27	A523	JAMB WEATHERSTRIP LOWER	2	URETHANE FOAM	SCHLEGEL
28	A52F	SASH STOP	2	RIGID PVC	CLIM-A-TECH
29	A522	ALUM. SNAP IN LOWER EXT. (OPT.)	2	ALUMINUM	HOMESHIELD
30	A030	SILICONE SEALANT	AS REQUIRED	SILICONE	DOW CORNING
31	A733	FOAM SILL FILLER	1	CLOSED CELLFOAM	CLIM-A-TECH
32	A43R	LOCK TERMINAL SHOE	2		UNIQUE BALANCE
33	A734	07 CDHV SILL CUSHION	1	CLOSED CELLFOAM	CLIM-A-TECH
34	A54P	INTERLOCK FUZZ PAD	1	FELT ADHESIVE BACK	AMESBURY
35	A72Y	FRAME CLEAT (MONUMENTAL)	1	GLASS FILLED NYLON	LCS
36	A00T	#7 x 7/8" FHWS S.S.	17	STEEL	ABILITY FASTENERS
37	A330	#8 x 1 1/2" FHWS Z&Y	2	STEEL	ABILITY FASTENERS
38	A70K	07 CORNER BLOCK	1		LCS
39	A11K	#6 x 7/16", #8 BODY FHMS S.S.	7	STAINLESS STEEL	ABILITY FASTENERS
40	A11D	7/16" x 1 3/4" 16 GA. STAPLE	6	GALVANIZED STEEL	ABILITY FASTENERS
41	A100	90 CORNER KEY	2	NYLON	LAKE COUNTRY SALES
42	A08W	MDL CORNER KEY	2	ABS COMPOUND	LAKE COUNTRY SALES
43	A02E	#8 x 1 3/4" FH SMS (Z&Y)	4	STEEL	ABILITY FASTENERS
44	A39W	#7 x 1 1/4" FH SMS (S.S.)	2	STEEL	ABILITY FASTENERS
45	A16K	SASH COVER	4	ALUMINUM	HYDRO
46	20F4	UPPER RAIL	1	WOOD	EAGLE WINDOW & DOOR
47	A40E	1" HARDENED STEEL BRAD (18 GA.)	AS REQUIRED	STEEL	ABILITY FASTENERS
48	A67M	.031 x .625 FOAM TAPE (GLASS STOP TAPE)	AS REQUIRED	POLYTHYLENE	ADHESIVE RESEARCH
49	220N	HORZ. COLONIAL GLAZING STOP	4	WOOD	EAGLE WINDOW & DOOR
50	A742	PIVOT PIN (DIE-CAST) "STD. DH"	4	ZAMACK-3	DECO
	A743	PIVOT PIN (S.S.) "MONUMENTAL SH"		STAINLESS STEEL	GIESE
51	20F4	UPPER STILE	2	WOOD	EAGLE WINDOW & DOOR
52	220J	VERT. COLONIAL GLAZING STOP	4	WOOD	EAGLE WINDOW & DOOR
53	A08J	5/8" INSULATED GLASS	1	GLASS	CARDINAL IG
	A32Y	SINGLE PANE GLASS (OPT.)		GLASS	CARDINAL IG
54	221H	GLAZING STOP	1	WOOD	EAGLE WINDOW & DOOR
55	A72N	KEEPER	2	ZAMACK-3	ASHLAND
56	A51H	INSTANT GLAZE II SEALANT	AS REQUIRED	POLYURETHANE	DOW CORNING
57	A00E	NEOPRENE GLASS SETTING BLOCK	AS REQUIRED	NEOPRENE RUBBER	CLIM-A-TECH



Architectural Testing

Test sample complies with these details.
Deviations are noted.

Report#

73120

Date

5/22/07 Tech TG

TITLE:	CDHV UNIT ASSEMBLY
FINISH:	
MATL:	
DFT:	KJS
DCN:	0881
DATE:	3/19/07
SCALE:	1=1
DRWG:	0534
C	11

NO. | DESCRIPTION | DFT | DOC | DATE

NO.	DWG NO.	DESCRIPTION	QUANTITY	MATERIAL	SUPPLIER
58	A08K	GLAZING SHIM .250 x .065 x 4.000	AS REQUIRED	NEOPRENE RUBBER	CLIM-A-TECH
59	A01A	.094 x .265 BUTYL TAPE	AS REQUIRED	BUTYL RUBBER	PTI INC.
60	A627	FOAM END PLUG	2	POLYETHYLENE	CLIM-A-TECH
61	A04T	#8 x 1/2" PH TEKS SCREW	AS REQUIRED	STEEL	ABILITY FASTENERS
62	20F2	UPPER CHECK RAIL	1	WOOD	EAGLE WINDOW & DOOR
63	A72W	CHECK RAIL COVER (UPPER)	1	ALUMINUM	HYDRO
64	A72T	WEATHER STRIP	1	VINYL	CLIM-A-TECH
65	A172	SASH CORNER KEY	4	NYLON	LAKE COUNTRY SALES
66	A01D	TYPE 1 BOND WOOD ADHESIVE	AS REQUIRED	COPOLYMER	NATIONAL STARCH
67	A00R	#7 x 5/8" FHSMS	2	STAINLESS STEEL	ABILITY FASTENERS
68	A72R	SURFACE TILT-LATCH	2	NYLON	HILL DESIGN
69					
70	A19H	#4 x 1/2" FHSMS	8	STAINLESS STEEL	ABILITY FASTENERS
71	A54J	DH HANDLE SCREW HOLE PLUG	2	NYLON	ASHLAND HARDWARE
72	A54L	#8-32 x 7/8" PPHMS, TRI-OBIAL	2	STEEL	ASHLAND HARDWARE
73	A54G	E-TILT DH LOCK HANDLE	2	ZAMACK-3	ASHLAND HARDWARE
74	A54H	E-TILT DH BEZEL PLATE	2	ZAMACK-3	ASHLAND HARDWARE
75	20F5	LOWER CHECK RAIL	1	WOOD	EAGLE WINDOW & DOOR
76	A72X	CHECK RAIL COVER (LOWER)	1	ALUMINUM	HYDRO
77	20F4	LOWER STILE	2	WOOD	EAGLE WINDOW & DOOR
78	A741	LOWER STILE COVER	2	ALUMINUM	HYDRO
79	A63A	FINGER LIFT	AS REQUIRED	ZAMACK-3	ASHLAND HARDWARE
80	A03Y	#6 x 1 FHSMS Z&Y (PAINTED HEAD)	AS REQUIRED	STEEL	ABILITY FASTENERS
81	A71X	LOWER RAIL COVER	1	ALUMINUM	HYDRO
82	20E8	LOWER RAIL	1	WOOD	EAGLE WINDOW & DOOR
83	A72G	LOWER SASH WEATHER STRIP	1		CLIM-A-TECH
84	A737	.031 x 1.125 SEALANT (BUTYL TAPE)	3	BUTYL RUBBER	DEVAN SEALANTS
85	A54N	#6 x 1 1/4" FHWS TEKS POINT S.S.	4	STAINLESS STEEL	ABILITY FASTENERS
86	A131	3/16 x 1 1/2 STAPLE (STD. DH)	6	GALVANIZED STEEL	ABILITY FASTENERS
87	A54F	E-TILT DOUBLE HUNG LOCK	2		ASHLAND HARDWARE
88	A67G	LOWER SASH PAD	2		CLIM-A-TECH
89	A72P	TILT-LATCH ARM	2	PVC	ASHLAND HARDWARE
90	A54D	SPRING WASHER	2	STAINLESS STEEL	ASHLAND HARDWARE
91	A48C	#8 x 2 1/4" COMBO ROUND WASHER HEAD	2	STEEL	ABILITY FASTENERS
92	H-40	5/8" BETWEEN GLASS MUNTIN	AS REQUIRED	ALUMINUM	ALLMETAL
93	P/PD	1" CONTOUR MUNTIN	AS REQUIRED	ALUMINUM	ALLMETAL
94	220H	1 1/2" INTERIOR COLONIAL MDL BAR	AS REQUIRED	WOOD	EAGLE WINDOW & DOOR
95	H-40	SPACER CHANNEL	AS REQUIRED	ALUMINUM	ALLMETAL
96	A507	1 1/2" EXTERIOR MDL BAR	AS REQUIRED	ALUMINUM	HYDRO
97	A67X	1 1/2" MDL ADHESIVE TAPE (EXTERIOR TAPE)	AS REQUIRED	POLYETHYLENE	ADHESIVE RESEARCH
98	A67L	1 1/2" MDL ADHESIVE TAPE (INTERIOR TAPE)	AS REQUIRED	POLYETHYLENE	ADHESIVE RESEARCH
99	220H	1 1/8" INTERIOR COLONIAL MDL BAR	AS REQUIRED	WOOD	EAGLE WINDOW & DOOR
100	H-40	SPACER CHANNEL	AS REQUIRED	ALUMINUM	ALLMETAL
101	A507	1 1/8" EXTERIOR MDL BAR	AS REQUIRED	ALUMINUM	HYDRO
102	A67W	1 1/8" MDL ADHESIVE TAPE (EXTERIOR TAPE)	AS REQUIRED	POLYETHYLENE	ADHESIVE RESEARCH
103	A67R	1 1/8" MDL ADHESIVE TAPE (INTERIOR TAPE)	AS REQUIRED	POLYETHYLENE	ADHESIVE RESEARCH
104	220H	7/8" INTERIOR COLONIAL MDL BAR	AS REQUIRED	WOOD	EAGLE WINDOW & DOOR
105	H-40	SPACER CHANNEL	AS REQUIRED	ALUMINUM	ALLMETAL
106	A507	7/8" EXTERIOR MDL BAR	AS REQUIRED	ALUMINUM	HYDRO
107	A67T	7/8" MDL ADHESIVE TAPE (EXTERIOR TAPE)	AS REQUIRED	POLYETHYLENE	ADHESIVE RESEARCH
108	A67N	7/8" MDL ADHESIVE TAPE (INTERIOR TAPE)	AS REQUIRED	POLYETHYLENE	ADHESIVE RESEARCH
109	20FA	5/8" INTERIOR COLONIAL MDL BAR	AS REQUIRED	WOOD	EAGLE WINDOW & DOOR
110	H-40	SPACER CHANNEL	AS REQUIRED	ALUMINUM	ALLMETAL
111	A72D	5/8" EXTERIOR MDL BAR	AS REQUIRED	ALUMINUM	HYDRO
112	A75N	5/8" MDL ADHESIVE TAPE (EXTERIOR TAPE)	AS REQUIRED	POLYETHYLENE	ADHESIVE RESEARCH
113	A75M	5/8" MDL ADHESIVE TAPE (INTERIOR TAPE)	AS REQUIRED	POLYETHYLENE	ADHESIVE RESEARCH
114	N/A	ADHESIVE FOAM TAPE	AS REQUIRED	POLYETHYLENE	CARDINAL

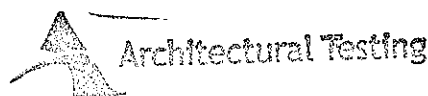

Test sample complies with these details.
Deviations are noted.

Report# 73120
Date 5/29-6/16/07 Tech [Signature]

TITLE:	CDHV
	UNIT ASSEMBLY
FINISH:	
MATL:	
DFT:	KJS
DCN:	0881
SCALE:	1=1
DRWG:	0534
DATE:	3/19/07
	C 12

NOTE: 1. UNLESS OTHERWISE SPECIFIED, ALL DIMENSIONS SHOWN ARE IN INCHES AND ALL TOLERANCES ARE TO BE: DEC. ±.005; FRAC. ±1/64; ANGLES ±1/2°.

PRODUCT	GLASS	A
(PRE '96 & NG) CLAD CASEMENT & AWNING	5/8"	.469
(PRE '96 & NG) CLAD CASEMENT PICTURE	3/4"	.469
CLAD PIANO HINGE CASEMENT	5/8"	.469
CLAD PIANO HINGE CASEMENT (3056 & ABOVE)	3/4"	.469
CLAD RADIUS CASEMENT	5/8" & 3/4"	.469
(PRE '96 & NG) CLAD DOUBLE / SINGLE HUNG	5/8"	.469
(PRE '96 & NG) CLAD DOUBLE HUNG PICTURE	5/8"	.469
CLAD DOUBLE HUNG TRANSOM	5/8"	.469
CLAD DOUBLE HUNG REPLACEMENT SASH	5/8"	.469
ALL CLAD (NON-RADIUS) AUXILIARY (0-15 SQ. FT.)	3/4"	.469
ALL CLAD (NON-RADIUS) AUXILIARY (15+ SQ. FT.)	1"	.469
CLAD SLIDING WINDOW	5/8"	.469
CLAD INSWING / OUTSWING FRENCH DOOR	3/4"	.469
CLAD FRENCH DOOR TRANSOM	3/4"	.469
CLAD PATIO / FRENCH SLIDING DOOR	3/4"	.469
(PRE '98) WOOD CASEMENT & AWNING	3/4"	.680
(PRE '98) WOOD CASEMENT PICTURE	3/4"	.680
(NG) WOOD CASEMENT & AWNING	5/8"	.469
(NG) WOOD CASEMENT PICTURE	5/8" & 3/4"	.469
WOOD PIANO HINGE CASEMENT	5/8"	.469
WOOD PIANO HINGE CASEMENT (3056 & ABOVE)	3/4"	.469
(PRE '96 & NG) WOOD DOUBLE / SINGLE HUNG	5/8"	.469
(PRE '96 & NG) WOOD DOUBLE HUNG PICTURE	5/8"	.469
WOOD SLIDING WINDOW	5/8"	.469
WOOD DOUBLE HUNG TRANSOM	5/8"	.469
WOOD DOUBLE HUNG REPLACEMENT SASH	5/8"	.469
WOOD (NON-RADIUS) AUXILIARY (0-15 SQ. FT.)	3/4"	.469
WOOD (NON-RADIUS) AUXILIARY (15+ SQ. FT.)	1"	.469
WOOD INSWING / OUTSWING FRENCH DOOR	3/4"	.469
WOOD FRENCH DOOR TRANSOM	3/4"	.469
WOOD PATIO / FRENCH SLIDING DOOR	3/4"	.469
CLAD & WOOD PATIO/FR. SLIDING DOOR (BLIND GLASS)	1"	.406
ALL CLAD AND WOOD WINDOWS AND DOORS EXCEPT AUXILIARY UNITS WHICH ALWAYS USES	SINGLE GLAZED H. MSTR MONO	.680

Architectural Testing

Test sample complies with these details. Deviations are noted.

Report# 73120
Date 5/29/07 Tech TC

PANEL STOPS	
PRODUCT	A
WOOD OUTSWING SIDELITE	.469
WOOD OUTSWING TRANSOM	.469
WOOD INSWING SIDELITE	.469
WOOD INSWING TRANSOM	.469
CLAD DHG PICTURE	.406

.062 x .062 CHAMFER

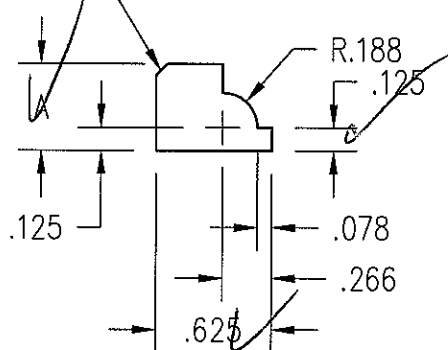

THIS DRAWING AND ITS CONTENTS ARE THE PROPERTY OF EAGLE WINDOW & DOOR. NO USE OR REPRODUCTION OF THE CONTENTS OF THIS DOCUMENT IS PERMITTED WITHOUT THE EXPRESS WRITTEN PERMISSION OF EAGLE WINDOW & DOOR.

TITLE: COLONIAL GLAZING STOP

FINISH:

04	ADDED CDHG PICT TO CHART	KJS	0881	3/6/07	MATL:
03	ADDED SIZE FOR IMPACT GLAZING	TWN	0972	9/1/05	EAGLE STD WOOD OFFERINGS
02	CHG'D CLAD PANEL STOP "A" DIM	JH	0794	6/30/05	DFT: JMH SCALE: 1=1
01	ADDED KYLER BLIND SIZE	TWN	0910	4/19/05	DCN: 0650 DRWG: 220J
NO	DESCRIPTION	DFT	DOC	DATE	DATE: 5/29/2002 A 01 OF 03

NOTE: 1. UNLESS OTHERWISE SPECIFIED, ALL DIMENSIONS SHOWN ARE IN INCHES AND ALL TOLERANCES ARE TO BE: DEC. ± 0.005 ; FRAC. $\pm 1/64$; ANGLES $\pm 1/2^\circ$.
 2. UNLESS OTHERWISE SPECIFIED ALL RADII = $.031$. DENOTED BY * (12 PLCS).



Architectural Testing

Test sample complies with these details.
 Deviations are noted.

Report# 73120
 Date 5/29-6/10/07 Tech TG

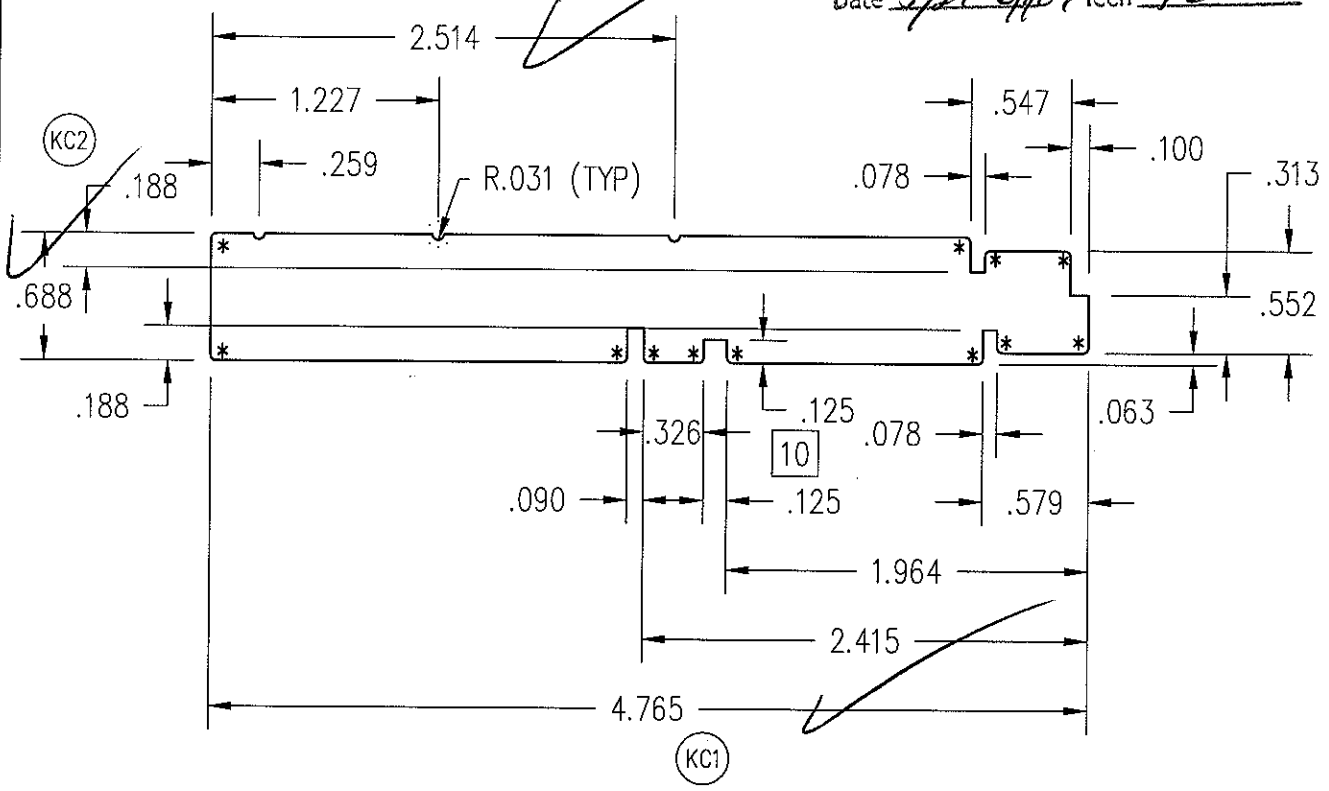

THIS DRAWING AND ITS CONTENTS ARE THE PROPERTY OF EAGLE WINDOW & DOOR. NO USE OR REPRODUCTION OF THE CONTENTS OF THIS DOCUMENT IS PERMITTED WITHOUT THE EXPRESS WRITTEN PERMISSION OF EAGLE WINDOW & DOOR.

TITLE: CDHV/CDHVET/CSW - HEAD
 CDHF - HEAD/SIDE JAMB

FINISH:

MATL: SEE PAGE 02

10	ADD 2ND KERF TO MATCH #2134	TWN	0768	1/30/03	DFT: BRL	SCALE: 1=1
09	ADDED E-TILT DHG	RJW	0589	6/26/02	DCN: 0215	DRWG: 21E9
NO	DESCRIPTION	DFT	DOC	DATE	DATE: 9/29/1995	A 01 OF 02

NOTE: 1. UNLESS OTHERWISE SPECIFIED, ALL DIMENSIONS SHOWN ARE IN INCHES AND ALL TOLERANCES ARE TO BE: DEC. ± 0.005 ; FRAC. $\pm 1/64$; ANGLES $\pm 1/2^\circ$.
 2. UNLESS OTHERWISE SPECIFIED ALL RADII = $.031$. DENOTED BY * (13 PLCS)



Test sample complies with these details.
 Deviations are noted.

Report# 73120
 Date 5/29-6/6/01 Tech JB

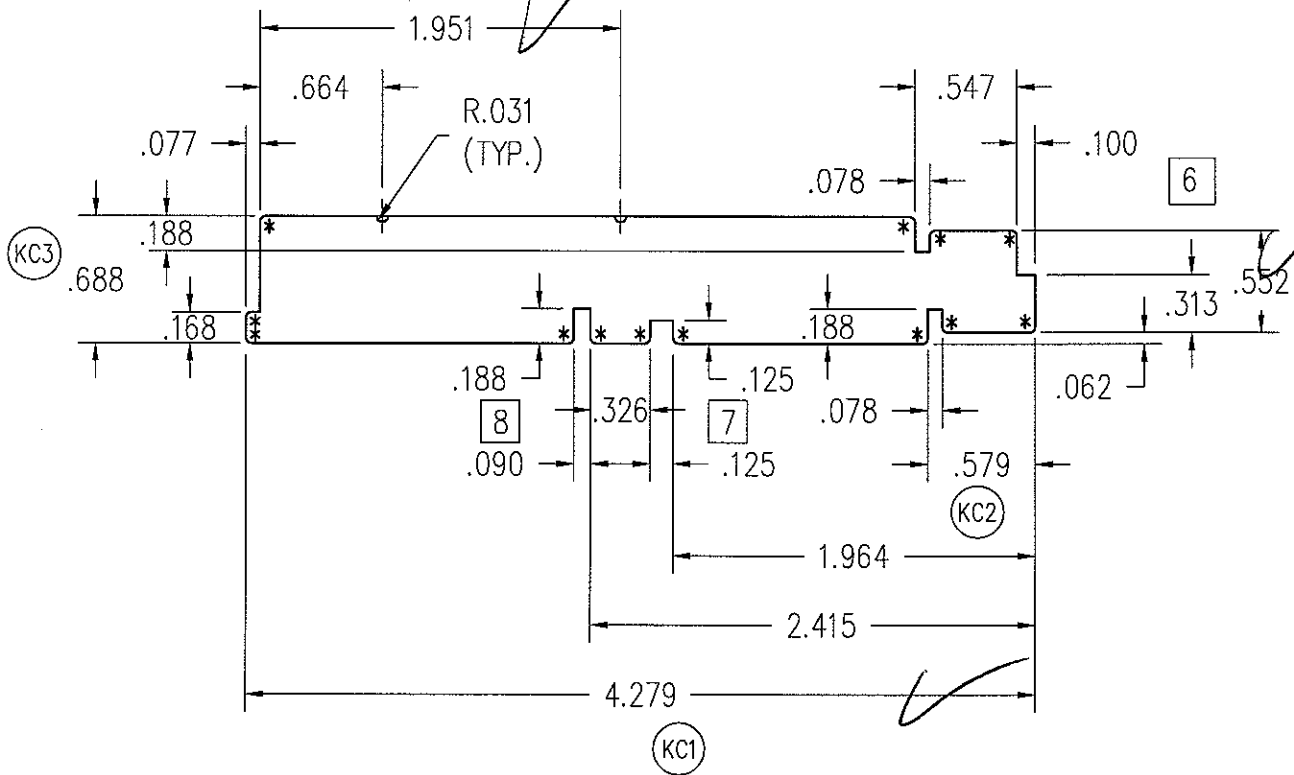

THIS DRAWING AND ITS CONTENTS ARE THE PROPERTY OF EAGLE WINDOW & DOOR. NO USE OR REPRODUCTION OF THE CONTENTS OF THIS DOCUMENT IS PERMITTED WITHOUT THE EXPRESS WRITTEN PERMISSION OF EAGLE WINDOW & DOOR.

TITLE: CDHV/CDHVET/CSW
 SIDE JAMB

FINISH:

08	ADD 2ND KEFT TO MATCH #21E9	TWN	0768	1/30/2003		
07	ADDED KERF FOR E-TILT	AWW	0589	5/26/2002	MATL:	SEE PAGE 02
06	CHNG'D PROFILE	AWW	0580	8/3/2001		
05	ADD RADIUS TO CORNERS	SCT	0292	5/1/1998	DFT:	GDE SCALE: 1=1
04	CHG'D DESCRIPTION	CEL	0247	5/5/1997	DCN:	0073 DRWG: 2134
NO	DESCRIPTION	DFT	DOC	DATE	DATE: 3/2/1993	A 01 OF 02

- NOTE: 1. UNLESS OTHERWISE SPECIFIED, ALL DIMENSIONS SHOWN ARE IN INCHES AND ALL TOLERANCES ARE TO BE: DEC. ± 0.005 ; FRAC. $\pm 1/64$; ANGLES $\pm 1/2^\circ$.
 2. L = FRAME WIDTH - $1 \frac{3}{8}$.

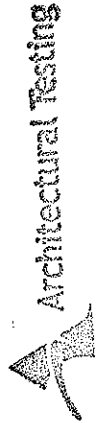

Test sample complies with these details. Deviations are noted.

Report# 25120
 Date 5/29-6/16/93 Tech TC

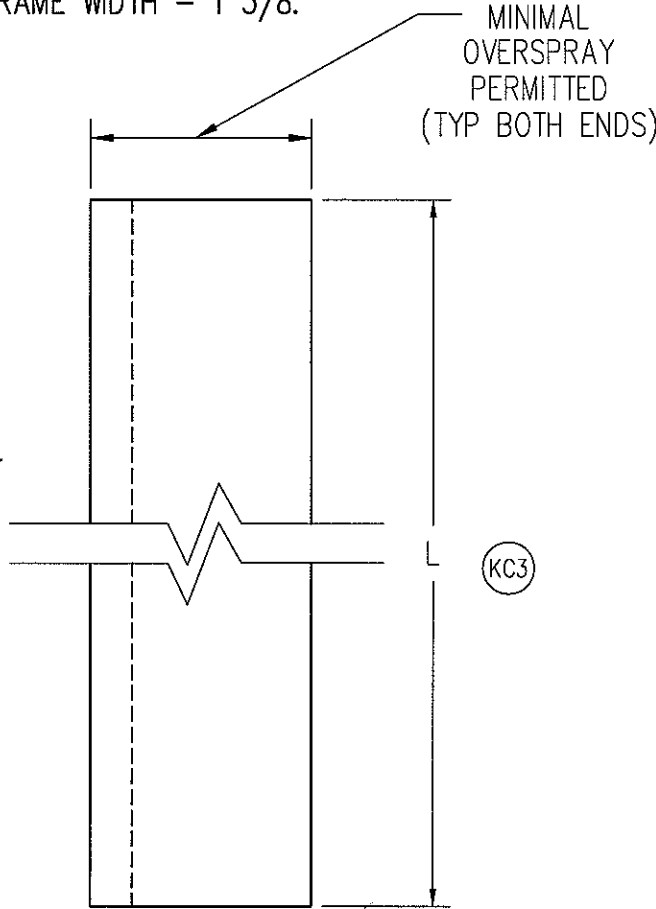

DOUBLE HUNG	
FRAME WIDTH	L
20	18 5/8
24	22 5/8
28	26 5/8
30	28 5/8
32	30 5/8
36	34 5/8
40	38 5/8
44	42 5/8
48	46 5/8
60	58 5/8

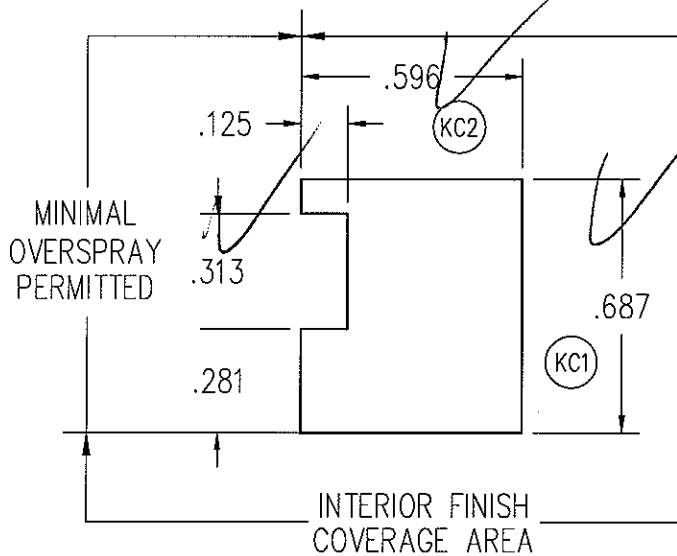

CSW / WSW	
FRAME WIDTH	L
36	34 5/8
48	46 5/8
60	58 5/8
72	70 5/8
96	94 5/8

THIS DRAWING AND ITS CONTENTS ARE THE PROPERTY OF EAGLE WINDOW & DOOR. NO USE OR REPRODUCTION OF THE CONTENTS OF THIS DOCUMENT IS PERMITTED WITHOUT THE EXPRESS WRITTEN PERMISSION OF EAGLE WINDOW & DOOR.

TITLE: CDHV,WDHV,CSW,WSW HEAD INTERIOR STOP

FINISH:

MATL: CLEAR PINE

DFT: GDE SCALE: 2=1

DCN: 0073 DRWG: 212N

DATE: 3/25/1993 A 01 OF 01

06	CHG'D PROFILE	JH	0840	8/15/2003
NO	DESCRIPTION	DFT	DOC	DATE

- Note: 1 UNLESS OTHERWISE SPECIFIED, ALL DIMENSIONS ARE SHOWN ARE IN INCHES AND ALL TOLERANCES ARE TO BE:
 DEC.+/- .005, FRACTION +/- 1/64, ANGLES +/- 1/2.
 2 L = FRAME HEIGHT - 2 11/16".
 3 LEFT & RIGHTS REQUIRED, LEFT HAND SHOWN (AS VIEWED FROM EXT.)
 4 HOLD 0.750 AT TENON BEFORE MOULDING

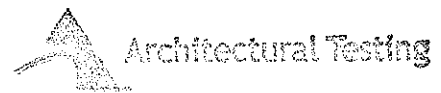
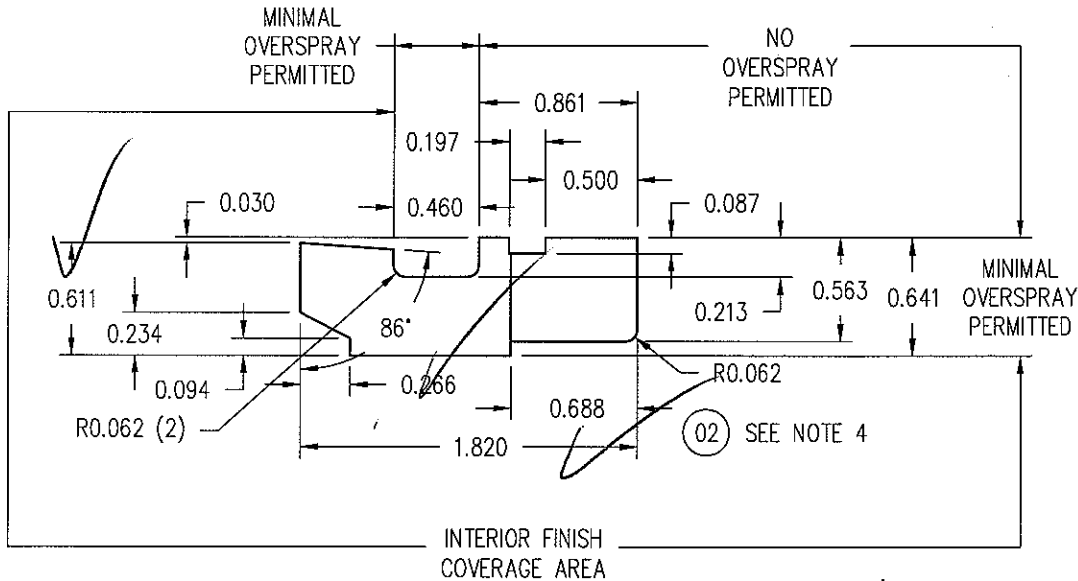

Test sample complies with these details.
 Deviations are noted.

Report# 73120
 Date 5/24 4/107 Tech TG

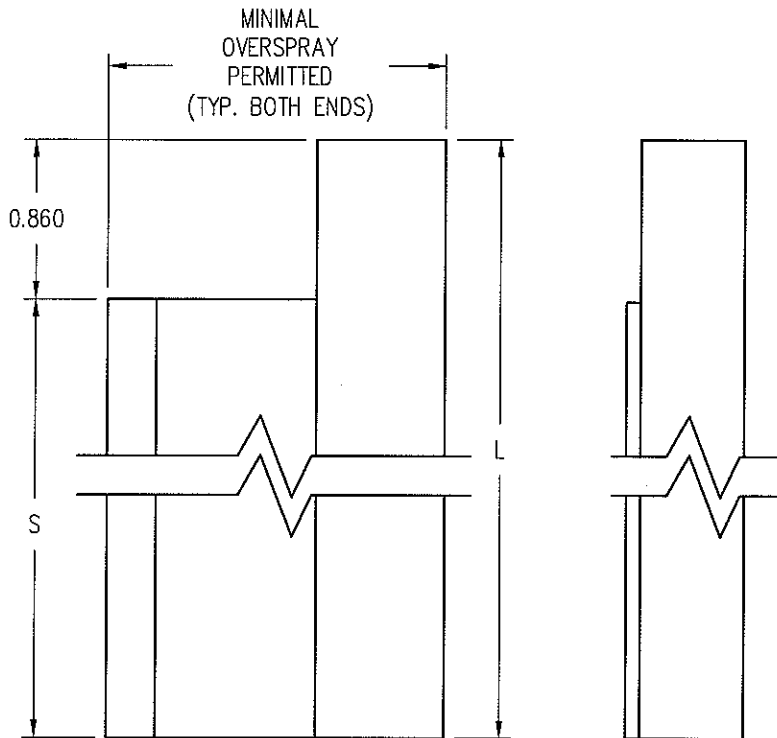

FRAME HEIGHT	L	S
36	33 5/16	32 7/16
40	37 5/16	36 7/16
48	45 5/16	44 7/16
54	51 5/16	50 7/16
60	57 5/16	56 7/16
66	63 5/16	62 7/16
72	69 5/16	68 7/16
78	75 5/16	74 7/16
84	81 5/16	80 7/16
90	87 5/16	86 7/16

02	ADDED NOTE #4	JH	0893	06/17/2004
01	ADD FILLET	PJB	0723	10/08/2002
NO	Description of Change	Drafter	DCN#	Date
Title: CDHVET/WDHVET SIDE INTERIOR STOP		Finish: INT FINISH SEE A02F		Material: CLEAR PINE
Scale: 1"=1"		Date: 1/18/2002		THIS DRAWING AND ITS CONTENTS ARE THE PROPERTY OF EAGLE WINDOW & DOOR. NO USE OR REPRODUCTION OF THE CONTENTS OF THIS DOCUMENT IS PERMITTED WITHOUT THE EXPRESS WRITTEN PERMISSION OF EAGLE WINDOW & DOOR.
Drafter: AWW		DCN# 0723		
			REVISION: 2	21Y9 01 of 01

Note: 1. UNLESS OTHERWISE SPECIFIED, ALL DIMENSIONS ARE SHOWN ARE IN INCHES AND ALL TOLERANCES ARE TO BE:
 DEC. +/- .005, FRACTION +/- 1/64, ANGLES +/- 1/2.
 2. L = FRAME WIDTH - 3 21/32".



Architectural Testing

Test sample complies with these details.
 Deviations are noted.

Report# 93120
 Date 5/18/07 Tech LG

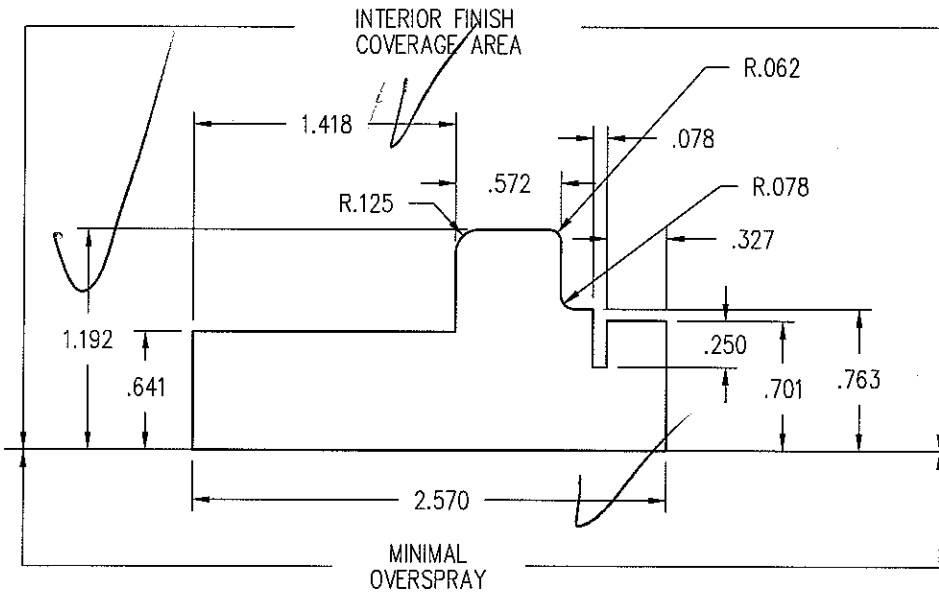
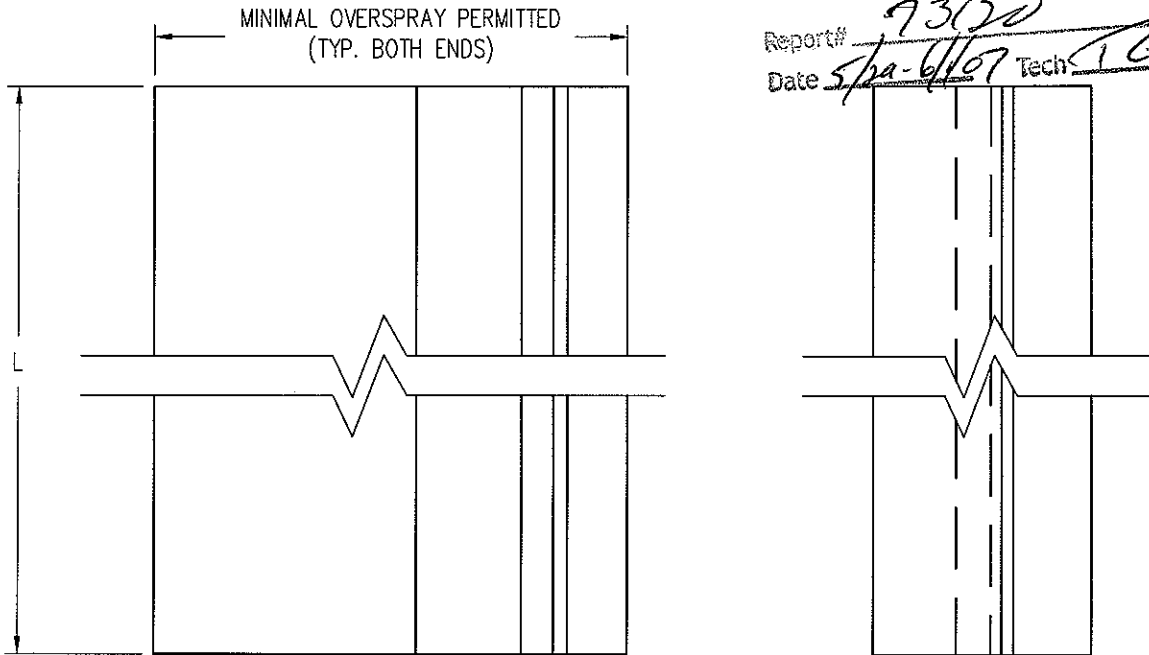

FRAME WIDTH	L
20	16 11/32
24	20 11/32
28	24 11/32
30	26 11/32
32	28 11/32
36	32 11/32
40	36 11/32
44	40 11/32
48	44 11/32
60	56 11/32

NO	Description of Change	Drafter	DCN#	Date
03	CHANGED PROFILE SIZE	TWN	0881	3/30/07
02	CHANGED SCALE	KJS	BOM	05/02/06
01	ADDED FINISH TO TITLE BLOCK	JH	0893	06/17/04

Title: CDHV/WDHV HEAD PARTING STOP		Finish: PRESERVATIVE	Material: CLEAR PINE
Scale: 1"=1"	Date: 1/18/2002	THIS DRAWING AND ITS CONTENTS ARE THE PROPERTY OF EAGLE WINDOW & DOOR. NO USE OR REPRODUCTION OF THE CONTENTS OF THIS DOCUMENT IS PERMITTED WITHOUT THE EXPRESS WRITTEN PERMISSION OF EAGLE WINDOW & DOOR.	
Drafter: AWW	DCN# 0589		

- NOTE: 1. UNLESS OTHERWISE SPECIFIED, ALL DIMENSIONS SHOWN ARE IN INCHES AND ALL TOLERANCES ARE TO BE: DEC. ± 0.005 ; FRAC. $\pm 1/64$; ANGLES $\pm 1/2^\circ$.
 2. L = FRAME WIDTH.

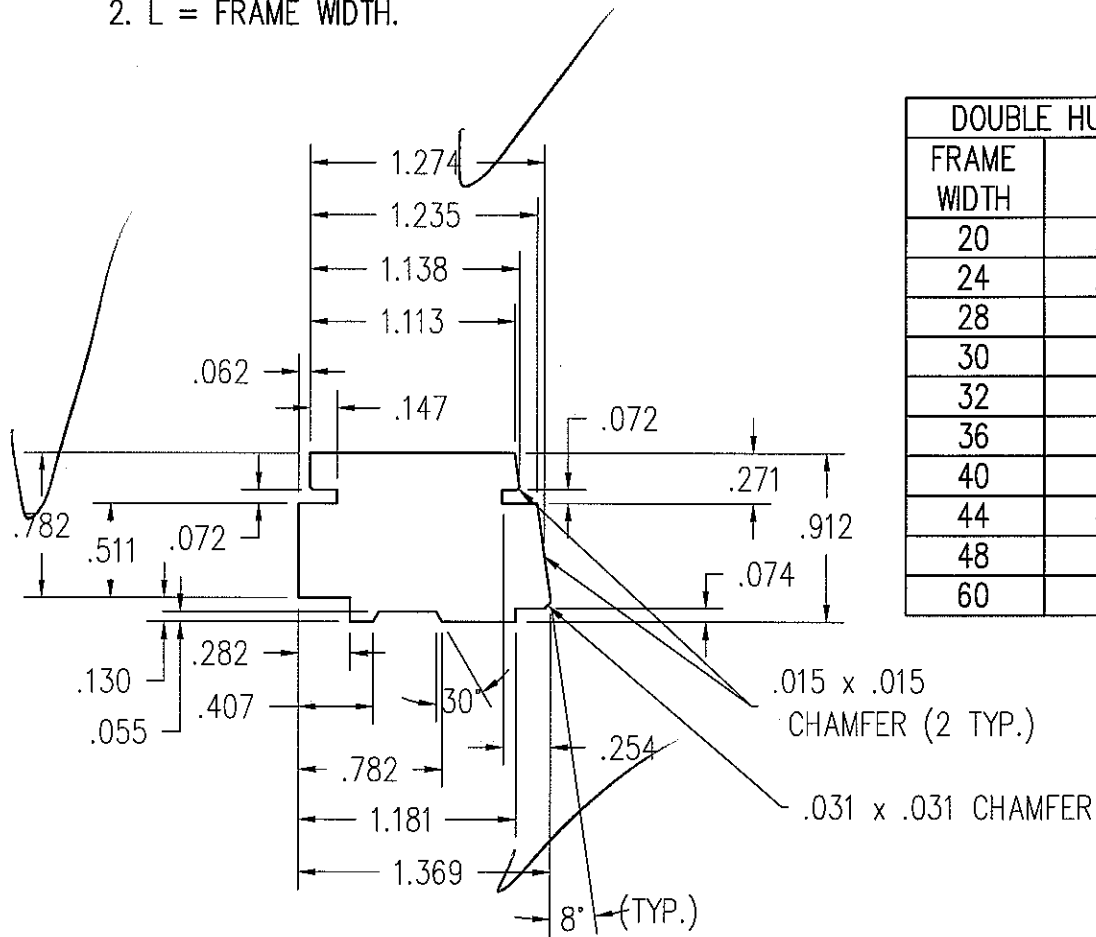

DOUBLE HUNG	
FRAME WIDTH	L
20	20
24	24
28	28
30	30
32	32
36	36
40	40
44	44
48	48
60	60

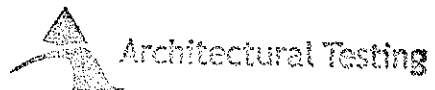
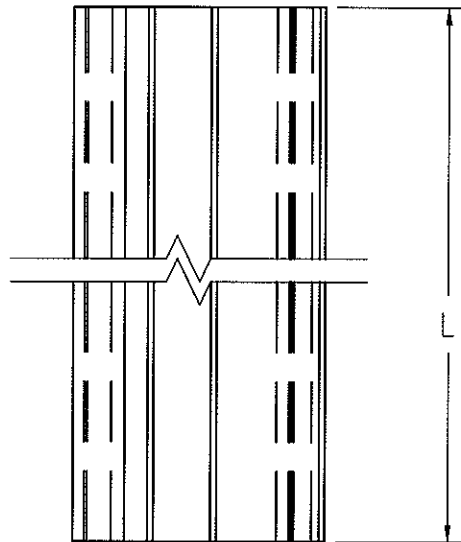

Test sample complies with these details.
 Deviations are noted.

Report# 73120
 Date 5/21-6/10/07 Tech TG

THIS DRAWING AND ITS CONTENTS ARE THE PROPERTY OF EAGLE WINDOW & DOOR. NO USE OR REPRODUCTION OF THE CONTENTS OF THIS DOCUMENT IS PERMITTED WITHOUT THE EXPRESS WRITTEN PERMISSION OF EAGLE WINDOW & DOOR.

TITLE: '07 DOUBLE HUNG THERMAL BLOCK

FINISH: PRESERVATIVE

MATL: EDGE GLUED AND FINGER JOINTED PINE

DFT: tnies SCALE: 1=1

01	UPDATED PROFILE	KJS	0881	1/4/07	DCN: 0881	DRWG: 20F1
NO	DESCRIPTION	DFT	DOC	DATE	DATE: 9/28/2006	A 01 OF 01

NOTE: 1. UNLESS OTHERWISE SPECIFIED, ALL DIMENSIONS SHOWN ARE IN INCHES AND ALL TOLERANCES ARE TO BE: DEC. ± 0.005 ; FRAC. $\pm 1/64$; ANGLES $\pm 1/2^\circ$.



Test sample complies with these details.
Deviations are noted.

Report# 73120
Date 5/29-6/6/07 Tech TG

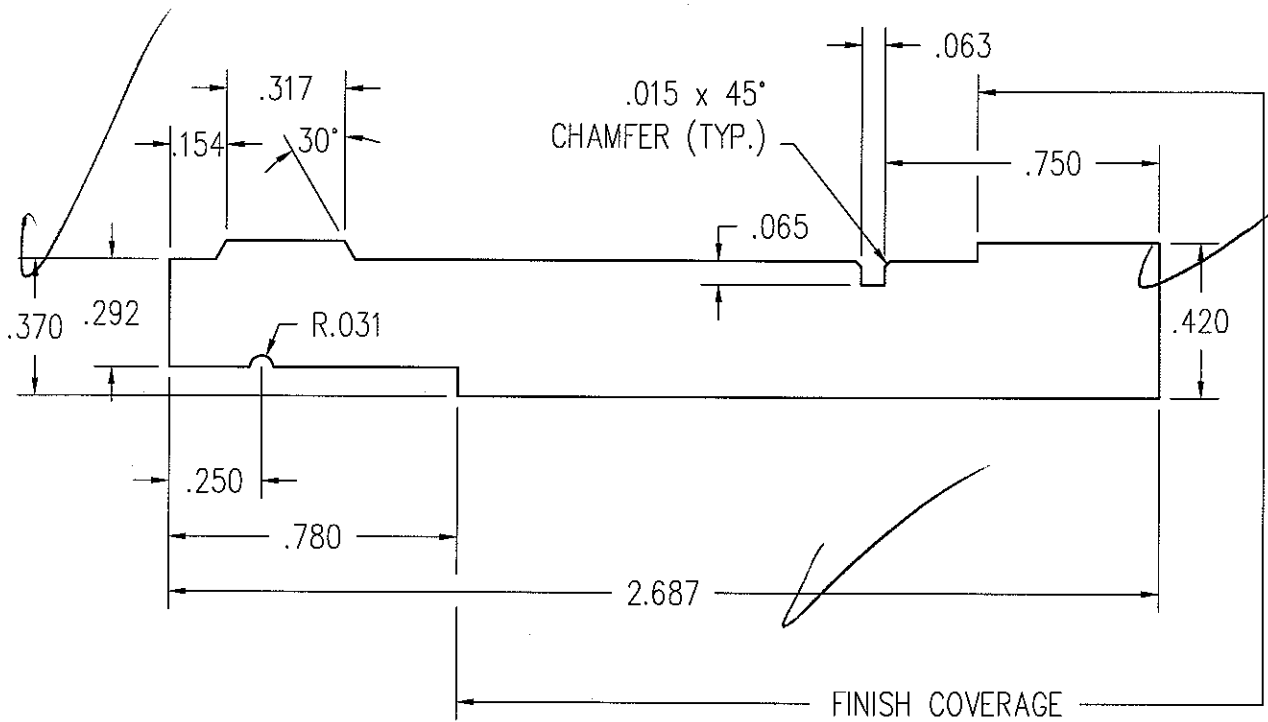

THIS DRAWING AND ITS CONTENTS ARE THE PROPERTY OF EAGLE WINDOW & DOOR. NO USE OR REPRODUCTION OF THE CONTENTS OF THIS DOCUMENT IS PERMITTED WITHOUT THE EXPRESS WRITTEN PERMISSION OF EAGLE WINDOW & DOOR.

TITLE: '07 SILL STOP

FINISH:

MATL: CLEAR PINE

DFT: tnies SCALE: 2=1

DCN: 0881 DRWG: 20F8

DATE: 12/12/2006 A 01 OF 02

NO	DESCRIPTION	DFT	DOC	DATE

- NOTE: 1. UNLESS OTHERWISE SPECIFIED, ALL DIMENSIONS SHOWN ARE IN INCHES AND ALL TOLERANCES ARE TO BE: DEC. ± 0.005 ; FRAC. $\pm 1/64$; ANGLES $\pm 1/2^\circ$.
 2. L = AFH - 4.344.



Architectural Testing

Test sample complies with these details.
 Deviations are noted.

Report# 93120
 Date 5/29-6/10/07 Tech TG

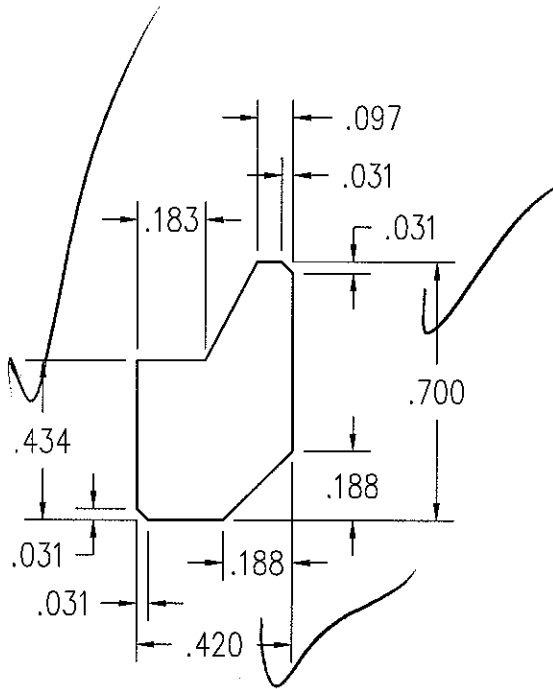

FRAME HEIGHT	L
72	67.656
78	73.656
84	79.656
90	85.656
96	91.656
102	97.656
108	103.656
114	109.656
120	115.656

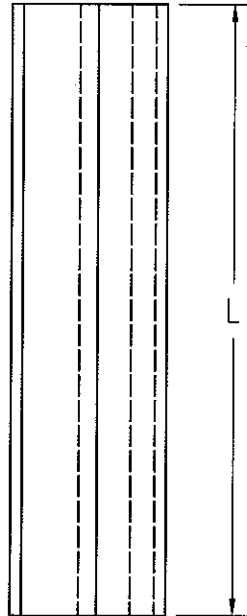

THIS DRAWING AND ITS CONTENTS ARE THE PROPERTY OF EAGLE WINDOW & DOOR. NO USE OR REPRODUCTION OF THE CONTENTS OF THIS DOCUMENT IS PERMITTED WITHOUT THE EXPRESS WRITTEN PERMISSION OF EAGLE WINDOW & DOOR.

TITLE: '07 CSHMV - INTERIOR SIDE STOP

FINISH:

MATL: CLEAR PINE

DFT: tnies SCALE: 2=1

DCN: 0881 DRWG: 20FL

DATE: 2/2/2007 A 01 OF 01

NO	DESCRIPTION	DFT	DOC	DATE

- NOTE: 1. UNLESS OTHERWISE SPECIFIED, ALL DIMENSIONS SHOWN ARE IN INCHES AND ALL TOLERANCES ARE TO BE: DEC. ± 0.005 ; FRAC. $\pm 1/64$; ANGLES $\pm 1/2^\circ$.
 2. UNLESS OTHERWISE SPECIFIED, WALL THICKNESS IS $.060$.
 3. UNLESS OTHERWISE SPECIFIED BREAK ALL CORNERS $.015$ RADIUS.
 4. AREA = $.572$ SQIN
 5. MILL PART NO. = # M5746 ,
 6. BON-L # EWD-285

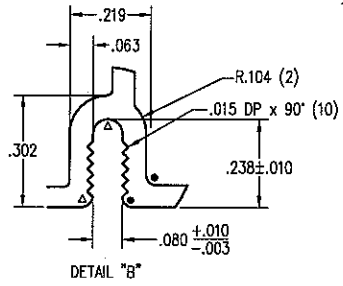
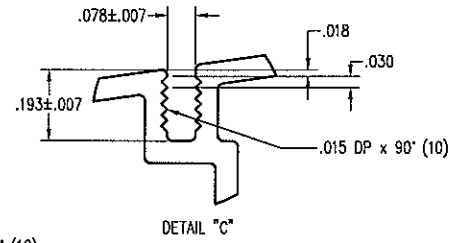
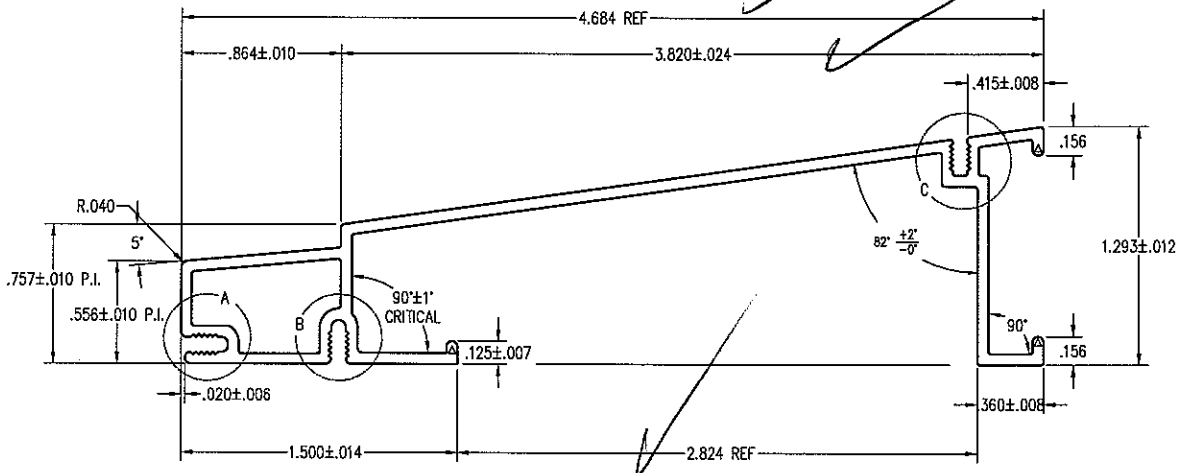
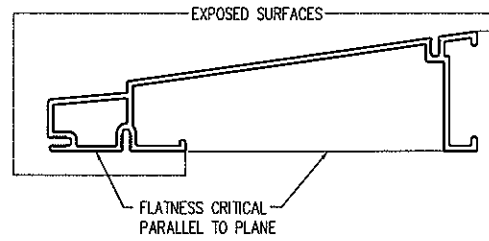

- R .028 (6)
- R .031 (2)
- x R .062 (0)
- △ FULL RAD.(4)

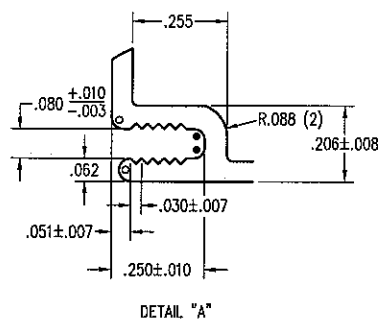

Architectural Testing

Test sample complies with these details.
 Deviations are noted.

Report# 73120
 Date 5/29-6/1/07 Tech 76

THIS DRAWING AND ITS CONTENTS ARE THE PROPERTY OF EAGLE WINDOW & DOOR. NO USE OR REPRODUCTION OF THE CONTENTS OF THIS DOCUMENT IS PERMITTED WITHOUT THE EXPRESS WRITTEN PERMISSION OF EAGLE WINDOW & DOOR.	
TITLE: CDH/CDF/CSW	
FINISH: SILL COVER (HOLLOW NOSE) EAGLE'S STD. COLORS	
MATERIAL: 6063 T-6 ALUMINUM	
DFT: PUB	SCALE: 1=1
DCN: 0734	DRWG: A571
DATE: 7/23/2002	C 01 OF 02

NO	DESCRIPTION	DFT	DOC	DATE

- NOTE: 1. UNLESS OTHERWISE SPECIFIED, ALL DIMENSIONS SHOWN ARE IN INCHES AND ALL TOLERANCES ARE TO BE: DEC. ± 0.05 ; FRAC. $\pm 1/64$; ANGLES $\pm 1/2^\circ$.
 2. UNLESS OTHERWISE SPECIFIED, WALL THICKNESS IS $.055$.
 3. UNLESS OTHERWISE SPECIFIED, BREAK ALL CORNERS $.010$ RADIUS.
 4. AREA = $.463$ SQ.IN.
 5. MILL PART NO. = #M5740

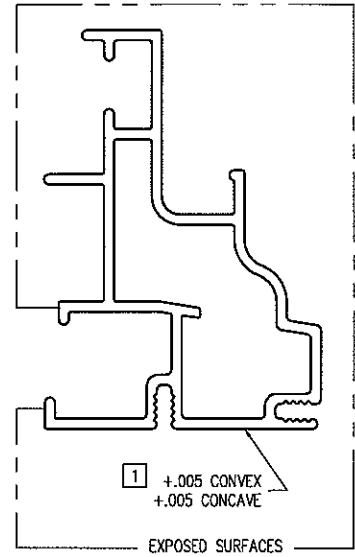
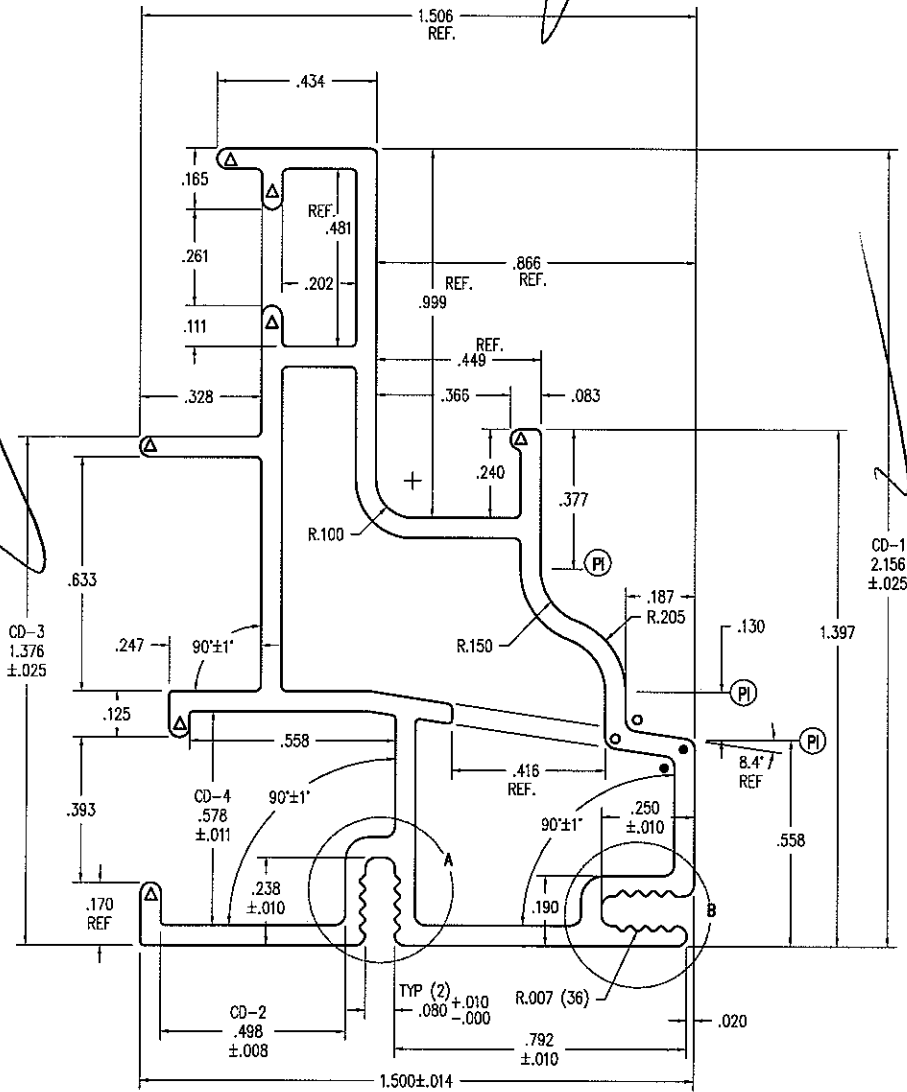

- R .028 (13)
- R .031 (3)
- X R .062 (2)
- △ FULL RAD.(5)

Architectural Testing
 Test sample complies with these details.
 Deviations are noted.
 Report# 73120
 Date 5/29-6/6/2001 Tech JG

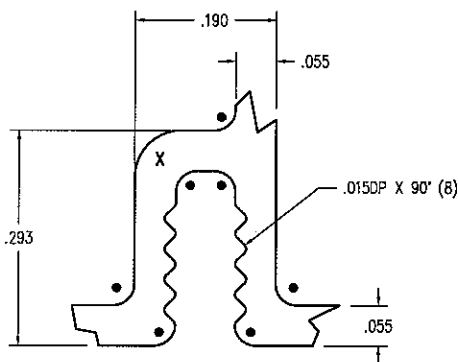

DETAIL "A"

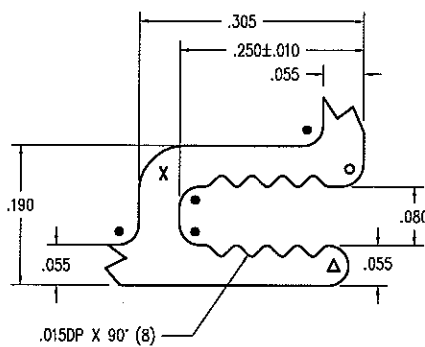

DETAIL "B"

THIS DRAWING AND ITS CONTENTS ARE THE PROPERTY OF EAGLE WINDOW & DOOR. NO USE OR REPRODUCTION OF THE CONTENTS OF THIS DOCUMENT IS PERMITTED WITHOUT THE EXPRESS WRITTEN PERMISSION OF EAGLE WINDOW & DOOR.	
TITLE: CHW/CHH/CSW	
FINISH: HEAD SIDE FRAME COVER	
MATERIAL: 6063 T-6 ALUMINUM	
DFT: AWW	SCALE: 2=1
NO: 01	DESCRIPTION: ADDED/CHG'D DIM. & TOLERANCE
TWN: 0778	DATE: 11/7/2001
DCN: 0867	DRWG: AS14
DFT: DOC	DATE: 11/7/2001
DATE: 11/7/2001	C 01 OF 03

NOTE: 1. UNLESS OTHERWISE SPECIFIED, ALL DIMENSIONS SHOWN ARE IN INCHES AND ALL TOLERANCES ARE TO BE: DEC. ± 0.005 ; FRAC. $\pm 1/64$; ANGLES $\pm 1/2^\circ$.
 2. TYPICAL RIGID WALL THICKNESS: .050.
 3. TYPICAL FLEXIBLE WALL THICKNESS: .020.

Test sample complies with these details.
 Deviations are noted.

Report# 93120
 Date 5/29-6/10/07 TB

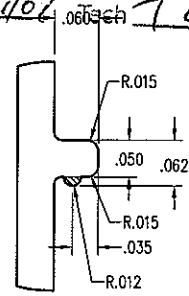
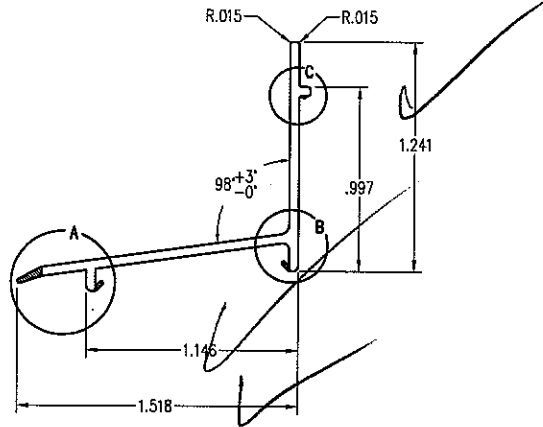

DETAIL C
 SCALE X 4

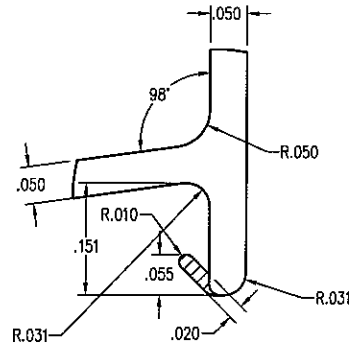

DETAIL B
 SCALE X 4

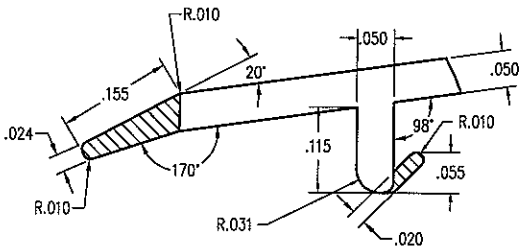

DETAIL A
 SCALE X 4

TOLERANCES (UNLESS NOTED)	
.000 - .125	± 0.010
.125 - .500	± 0.015
.500 - 2.00	± 0.020
2.00 - 4.00	± 0.030
4.00 - 5.00	± 0.040
WALLS	± 0.005
ANGLES	$\pm 3^\circ$

THIS DRAWING AND ITS CONTENTS ARE THE PROPERTY OF EAGLE WINDOW & DOOR. NO USE OR REPRODUCTION OF THE CONTENTS OF THIS DOCUMENT IS PERMITTED WITHOUT THE EXPRESS WRITTEN PERMISSION OF EAGLE WINDOW & DOOR.

TITLE: 07 SILL WATER DAM

FINISH:

MATL: BEIGE VINYL

DFT: ksmith SCALE: 1=1

DCN: 0881 DRWG: A74H

DATE: 2/28/2007 C 01 OF 02

NO	DESCRIPTION	DFT	DOC	DATE

- NOTE: 1. UNLESS OTHERWISE SPECIFIED, ALL DIMENSIONS SHOWN ARE IN INCHES AND ALL TOLERANCES ARE TO BE: DEC. ± 0.005 ; FRAC. $\pm 1/64$; ANGLES $\pm 1/2^\circ$.
2. WALL THICKNESS = .045
3. AREA = .569 SQ. IN.
4. ALL UNSPECIFIED RADII = .015
5. DIMENSIONS MARKED IN A [BOX] ARE CRITICAL.

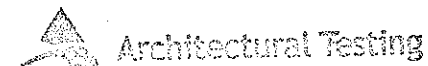

Test sample complies with these details.
Deviations are noted.

Report# 73120
Date 5/22-6/1/02 Tech AG

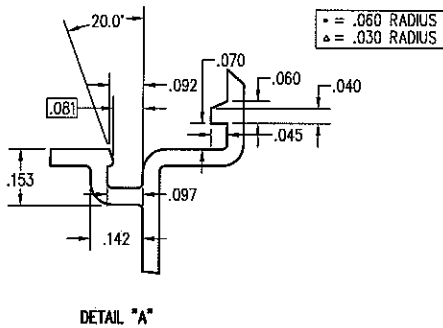
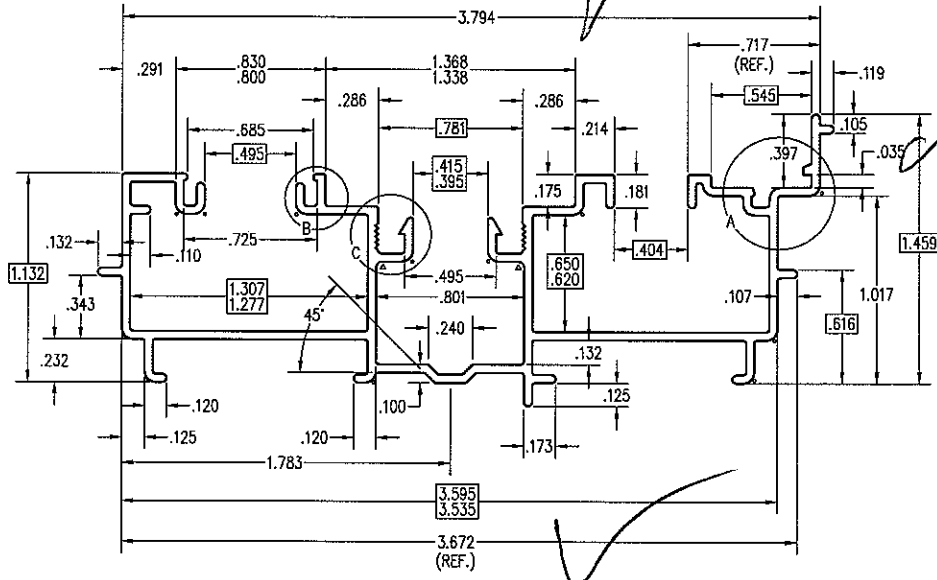

DETAIL "A"

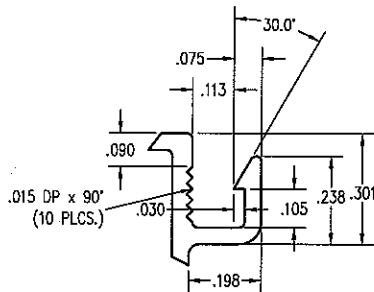

DETAIL "C"

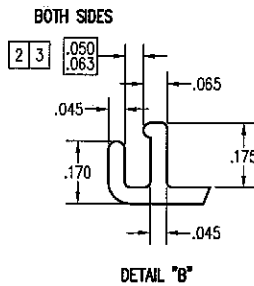

DETAIL "B"

PVC TOLERANCES

.000-.125	$\pm .010$
.125-.500	$\pm .015$
.500-2.00	$\pm .020$
2.00-4.00	$\pm .030$
4.00-5.00	$\pm .040$
WALLS	$\pm .005$
ANGLES	$\pm 3'$

THIS DRAWING AND ITS CONTENTS ARE THE PROPERTY OF
EAGLE WINDOW & DOOR. NO USE OR REPRODUCTION OF THE
CONTENTS OF THIS DOCUMENT IS PERMITTED WITHOUT THE
EXPRESS WRITTEN PERMISSION OF EAGLE WINDOW & DOOR.

TITLE: CHVET/WDHVEI
RIGID JAMBLINER
FINISH: BEIGE, WHITE
MATERIAL: RIGID PVC

03	CHANGED DIM/TOLERANCE	TWN	0805 17/9/2003				
02	ADDED .045 CRITICAL DIM	PJB	0784 5/27/2003DFT:	AWW	SCALE:	1=1	
01	ADDED CRITICAL INDICATORS	TWN	0730 2/20/2003DCN:	0589	DRWG:	A48X	
NO	DESCRIPTION	DFT	DOC	DATE	DATE:	6/21/2001	C 01 OF 05

- NOTE: 1. UNLESS OTHERWISE SPECIFIED, ALL DIMENSIONS SHOWN ARE IN INCHES AND ALL TOLERANCES ARE TO BE: DEC. $\pm .005$; FRAC. $\pm 1/64$; ANGLES $\pm 1/2^\circ$.
2. WALL THICKNESS = .045.
3. AREA = .0808 SQ. IN.
4. ALL RADII = .015.

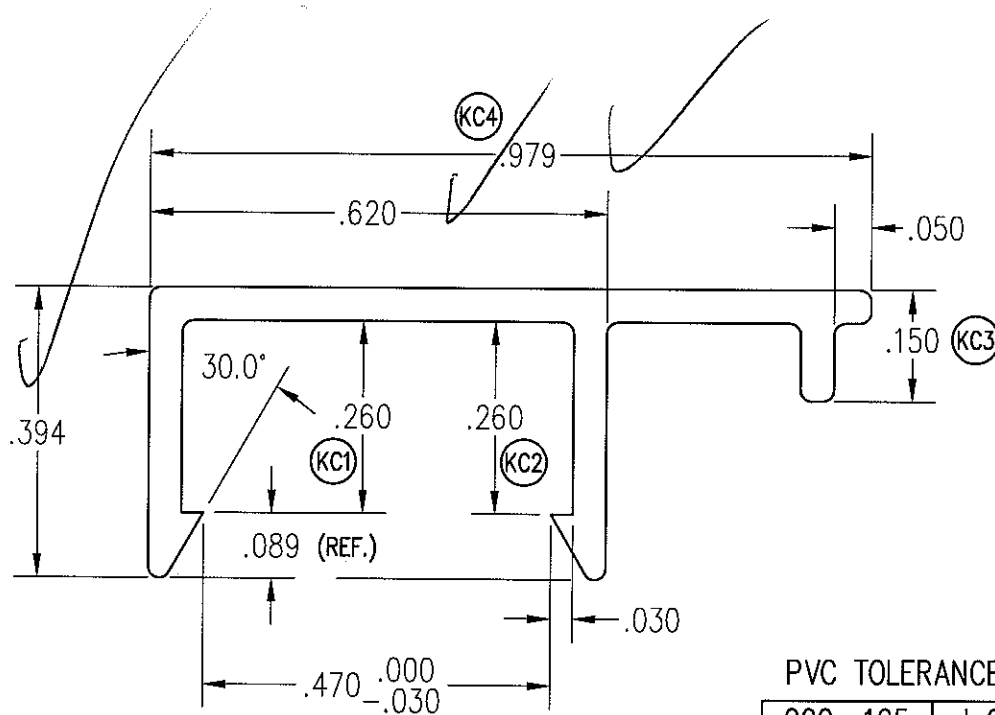

PVC TOLERANCES

.000-.125	$\pm .010$
.125-.500	$\pm .015$
.500-2.00	$\pm .020$
2.00-4.00	$\pm .030$
4.00-5.00	$\pm .040$
WALLS	$\pm .005$
ANGLES	$\pm 3^\circ$



Architectural Testing

Test sample complies with these details.
Deviations are noted.

Report# 73170
Date 5/29/07 Tech AB

THIS DRAWING AND ITS CONTENTS ARE THE PROPERTY OF EAGLE WINDOW & DOOR. NO USE OR REPRODUCTION OF THE CONTENTS OF THIS DOCUMENT IS PERMITTED WITHOUT THE EXPRESS WRITTEN PERMISSION OF EAGLE WINDOW & DOOR.

TITLE: CDHV/WDHV
PVC JAMBLINER COVER

FINISH: BEIGE, WHITE

MATL: RIGID PVC

DFT: PJB SCALE: 4=1

DCN: 0589 DRWG: A48Y

DATE: 6/21/2001 A 01 OF 03

01	ADDED CRITICAL DIM & TOL. BLK.	PJB	PRE	6/4/2002
NO	DESCRIPTION	DFT	DOC	DATE

- NOTE: 1. UNLESS OTHERWISE SPECIFIED, ALL DIMENSIONS SHOWN ARE IN INCHES AND ALL TOLERANCES ARE TO BE: DEC. ± 0.005 ; FRAC. $\pm 1/64$; ANGLES $\pm 1/2^\circ$.
2. WALL THICKNESS IS .045.
3. ALL RADII = .015, UNLESS NOTED.

Architectural Testing

Test sample complies with these details.
Deviations are noted.

Report# 73120
Date 5/29-6/10/07 Tech T6

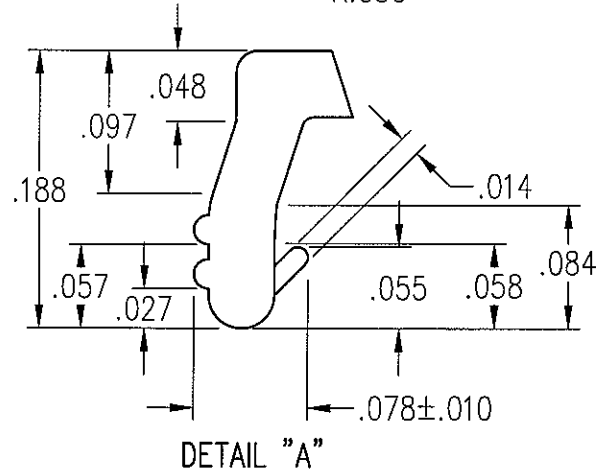
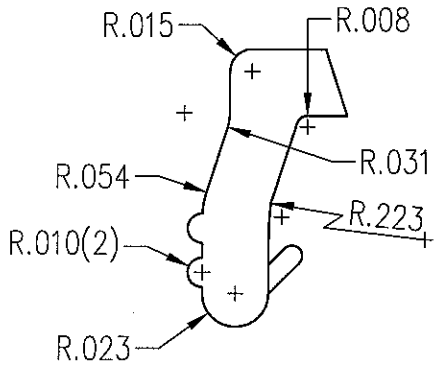
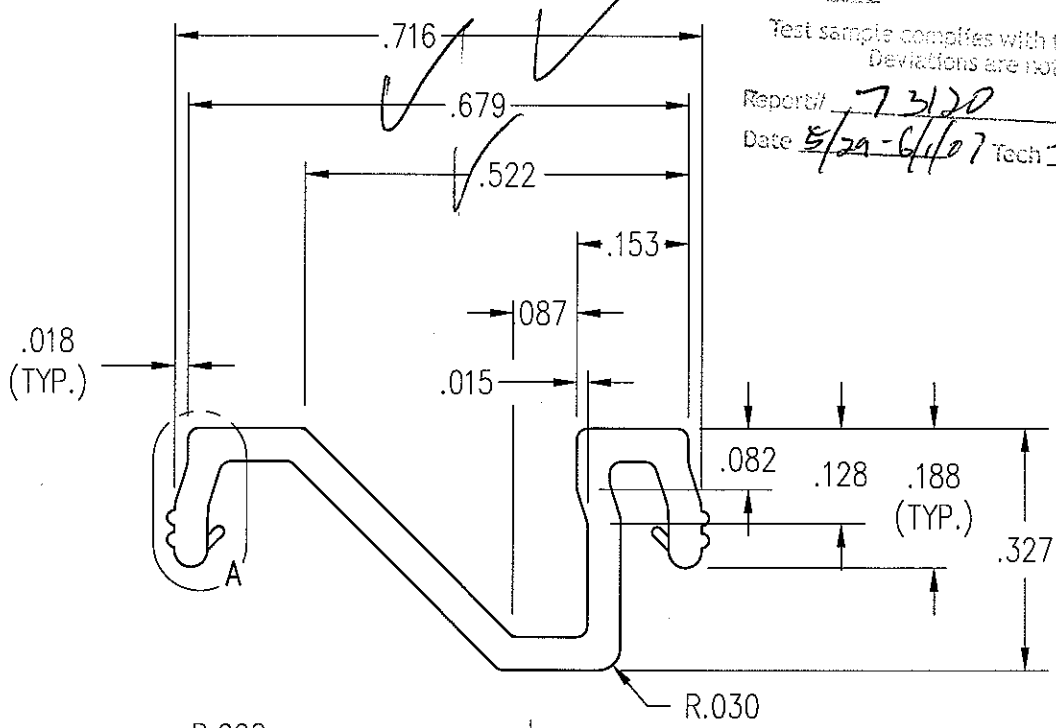

PVC TOLERANCES

.000-.125	± 0.010
.125-.500	± 0.015
.500-2.00	± 0.020
2.00-4.00	± 0.030
4.00-5.00	± 0.040
WALLS	± 0.005
ANGLES	$\pm 3^\circ$

THIS DRAWING AND ITS CONTENTS ARE THE PROPERTY OF EAGLE WINDOW & DOOR. NO USE OR REPRODUCTION OF THE CONTENTS OF THIS DOCUMENT IS PERMITTED WITHOUT THE EXPRESS WRITTEN PERMISSION OF EAGLE WINDOW & DOOR.	
TITLE:	'07 CDHV SPRING COVER
FINISH:	BEIGE, WHITE
MATL:	PVC
DFT:	ksmith
DCN:	0881
SCALE:	4=1
DRWG:	A71N
DATE:	1/29/2007
	A 01 OF 02

NO	DESCRIPTION	DFT	DOC	DATE
----	-------------	-----	-----	------

NOTE: 1. UNLESS OTHERWISE SPECIFIED, ALL DIMENSIONS SHOWN ARE IN INCHES AND ALL TOLERANCES ARE TO BE: DEC. ± 0.005 ; FRAC. $\pm 1/64$; ANGLES $\pm 1/2^\circ$.
 2. DOUGLAS FIR LVL IS REQUIRED.



Test sample complies with these details.
 Deviations are noted.

Report# 73120
 Date 5/29-6/10/07 Tech TB

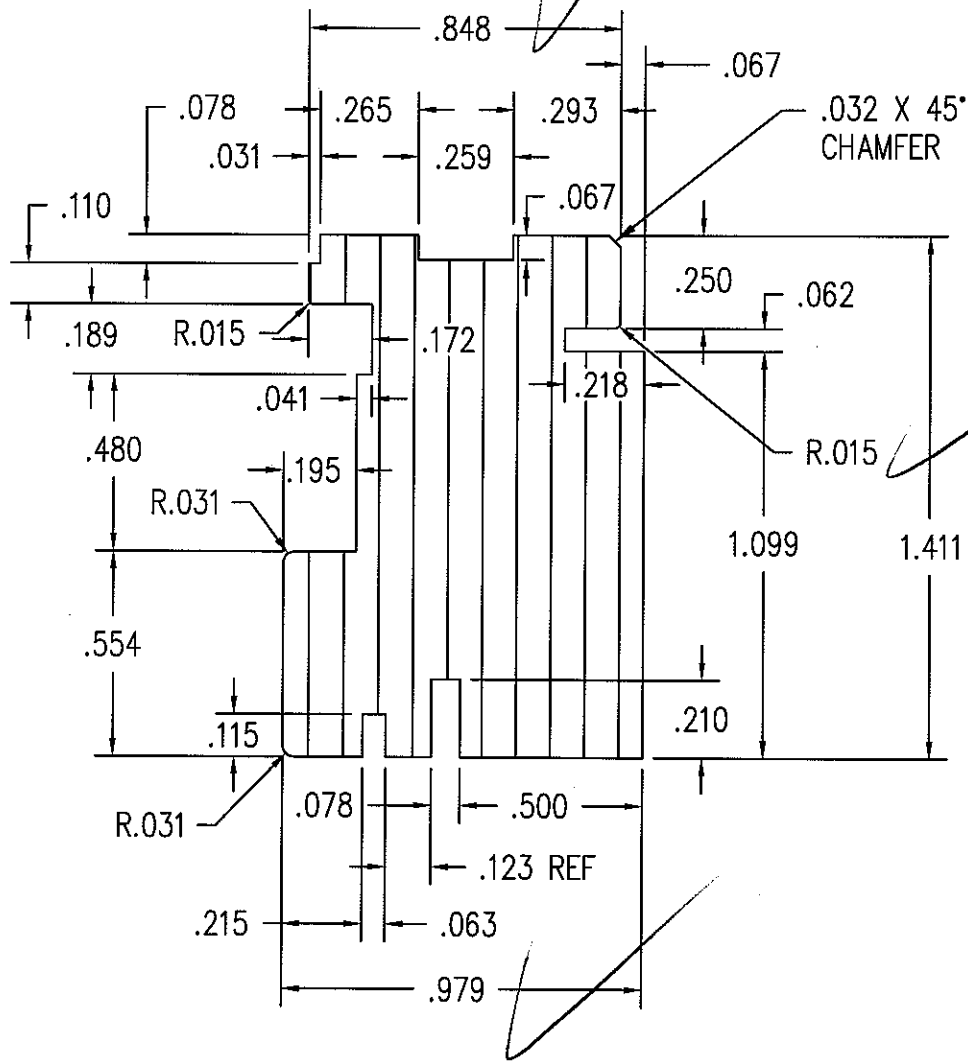

THIS DRAWING AND ITS CONTENTS ARE THE PROPERTY OF EAGLE WINDOW & DOOR. NO USE OR REPRODUCTION OF THE CONTENTS OF THIS DOCUMENT IS PERMITTED WITHOUT THE EXPRESS WRITTEN PERMISSION OF EAGLE WINDOW & DOOR.

TITLE: '07 CLAD DOUBLE HUNG UPPER CHECK RAIL

FINISH:

MATL: SEE NOTE #2

03	CHANGED PROFILE	TWN	PRE	3/20/07		
02	REVISED PROFILE	TWN	PRE	1/15/07	DFT: tnies	SCALE: 2=1
01	UPDATED PROFILE	KJS	0881	1/4/07	DCN: 0881	DRWG: 20F2
NO	DESCRIPTION	DFT	DOC	DATE	DATE: 9/28/2006	A 01 OF 02

NOTE: 1. UNLESS OTHERWISE SPECIFIED, ALL DIMENSIONS SHOWN ARE IN INCHES AND ALL TOLERANCES ARE TO BE: DEC. ± 0.005 ; FRAC. $\pm 1/64$; ANGLES $\pm 1/2^\circ$.

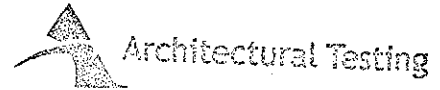

Test sample complies with these details.
Deviations are noted.

Report# 73120
Date 5/29-6/1/07 Tech TG

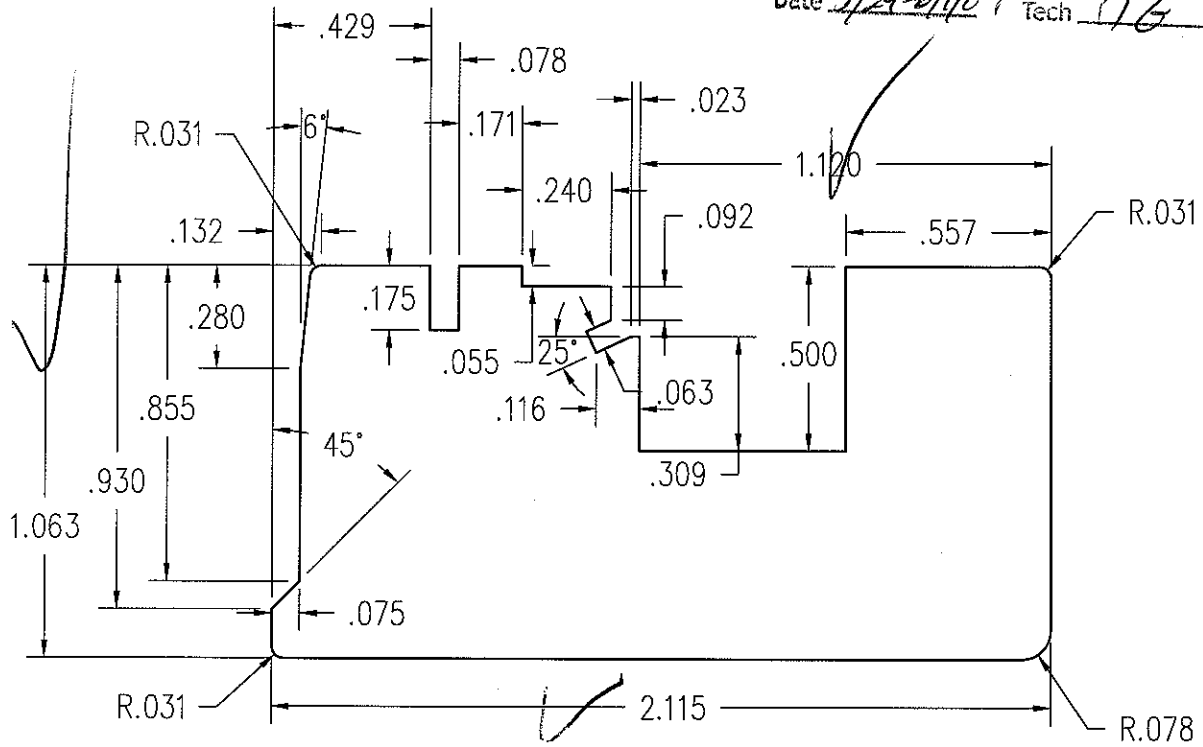

THIS DRAWING AND ITS CONTENTS ARE THE PROPERTY OF EAGLE WINDOW & DOOR. NO USE OR REPRODUCTION OF THE CONTENTS OF THIS DOCUMENT IS PERMITTED WITHOUT THE EXPRESS WRITTEN PERMISSION OF EAGLE WINDOW & DOOR.

TITLE: '07 CLAD DOUBLE HUNG LOWER CHECK RAIL

FINISH:

MATL: CLEAR PINE

DFT: tnies SCALE: 2=1

DCN: 0881 DRWG: 20F5

01	UPDATED PROFILE	KJS	0881	1/4/07	DATE: 9/28/2006	A	01 OF 02
NO	DESCRIPTION	DFT	DOC	DATE			

NOTE: 1. UNLESS OTHERWISE SPECIFIED, ALL DIMENSIONS SHOWN ARE IN INCHES AND ALL TOLERANCES ARE TO BE: DEC. ± 0.005 ; FRAC. $\pm 1/64$; ANGLES $\pm 1/2^\circ$.

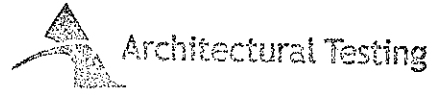

Test sample complies with these details.
Deviations are noted.

Report# 73100
Date 5/29-4/07 Tech 16

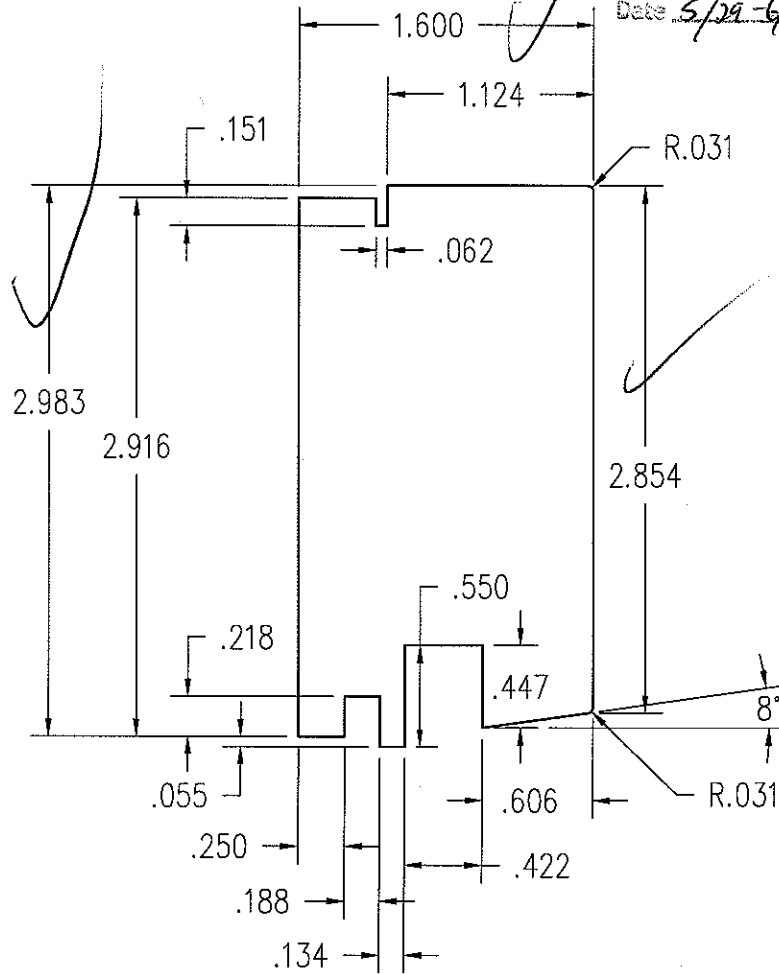

THIS DRAWING AND ITS CONTENTS ARE THE PROPERTY OF EAGLE WINDOW & DOOR. NO USE OR REPRODUCTION OF THE CONTENTS OF THIS DOCUMENT IS PERMITTED WITHOUT THE EXPRESS WRITTEN PERMISSION OF EAGLE WINDOW & DOOR.

TITLE: '07 CDHV, CDHF
WIDE RAIL

FINISH:

MATL: CLEAR PINE

DFT: tnies SCALE: 1=1

DCN: 0881 DRWG: 20E8

NO	DESCRIPTION	DFT	DOC	DATE
				DATE: 9/29/2006
				A 01 OF 02

- NOTE: 1. UNLESS OTHERWISE SPECIFIED, ALL DIMENSIONS SHOWN ARE IN INCHES AND ALL TOLERANCES ARE TO BE: DEC. $\pm .005$; FRAC. $\pm 1/64$; ANGLES $\pm 1/2^\circ$.
 2. TYPICAL WALL THICKNESS $.050 \pm .005$.
 3. UNSPECIFIED RADIUS TO BE $.015$.

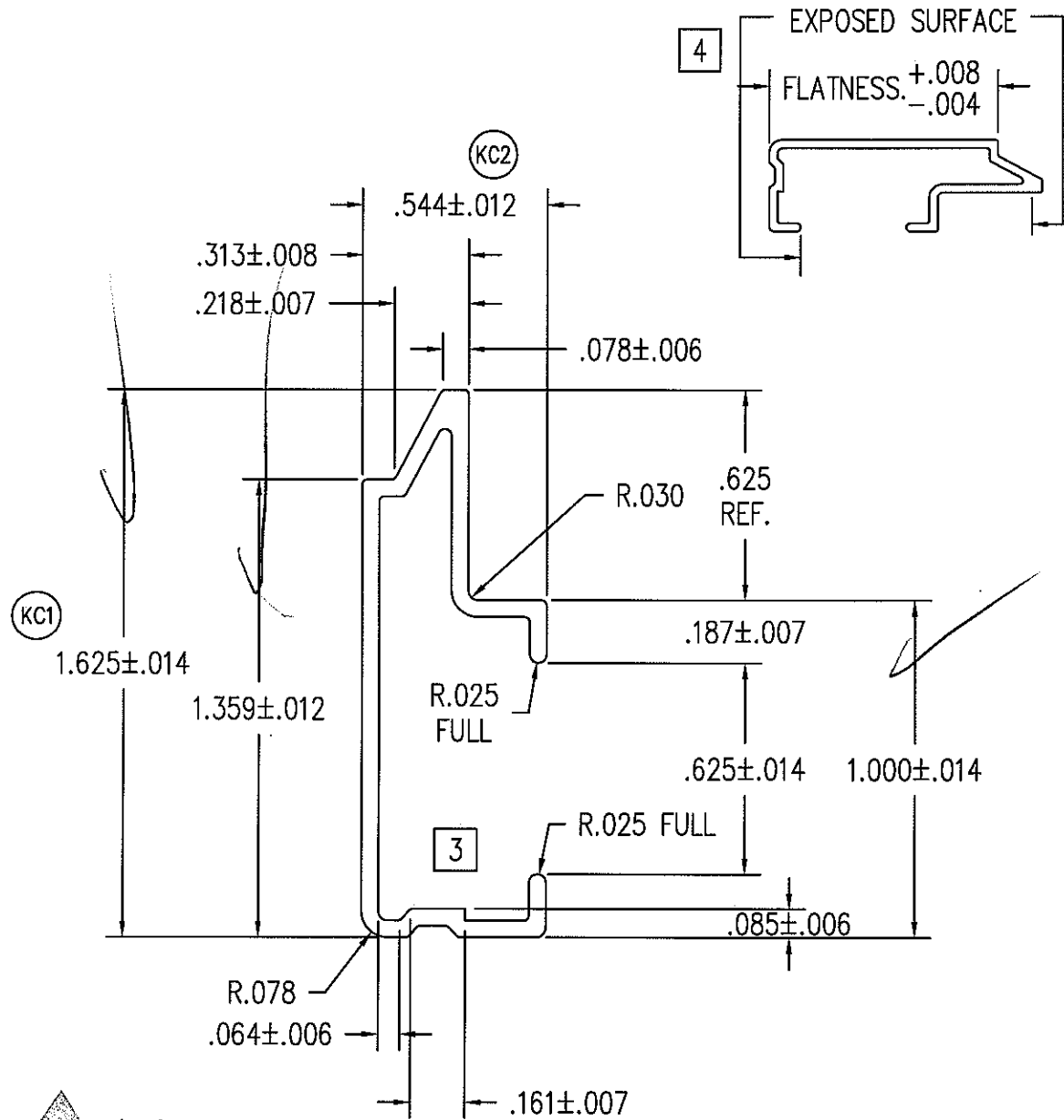

Architectural Testing
 Test sample complies with these details.
 Deviations are noted.

Report# 73120
 Date 5/29-6/1/07 Tech TG

THIS DRAWING AND ITS CONTENTS ARE THE PROPERTY OF EAGLE WINDOW & DOOR. NO USE OR REPRODUCTION OF THE CONTENTS OF THIS DOCUMENT IS PERMITTED WITHOUT THE EXPRESS WRITTEN PERMISSION OF EAGLE WINDOW & DOOR.
 TITLE: CDHV, CDHF, CSW, CDHVET SASH COVER
 FINISH: EAGLE'S STD. COLORS

05	ADDED E-TILT DHG	RJW	0589	6/26/2002		
04	ADDED TOLERANCE SPECS.	TWN	0595	8/31/2001	MATL:	6063 T-6 ALUMINUM OR EQUIVALENT
03	REVISED PROFILE	CEL	0366	10/27/1998	DFT:	GDE SCALE: 2=1
02	CHG'D DESCRIPTION	CEL	0247	4/14/1997	DCN:	0073 DRWG: A16K
01	PROFILE REDESIGNED	BRL	0215	8/29/1995	DATE:	3/26/1993 A 01 OF 02
NO	DESCRIPTION	DFT	DOC	DATE	DATE:	3/26/1993 A 01 OF 02

- NOTE: 1. UNLESS OTHERWISE SPECIFIED, ALL DIMENSIONS SHOWN ARE IN INCHES AND ALL TOLERANCES ARE TO BE: DEC. ± 0.005 ; FRAC. $\pm 1/64$; ANGLES $\pm 1/2^\circ$.
 2. TYPICAL WALL THICKNESS .055
 3. ALL RADII TO BE .010 UNLESS OTHERWISE SPECIFIED.
 4. AREA = .171 SQ. IN.



Architectural Testing

Test sample complies with these details.
 Deviations are noted.

Report# 73120
 Date 5/29-6/1/07 Tech. JG

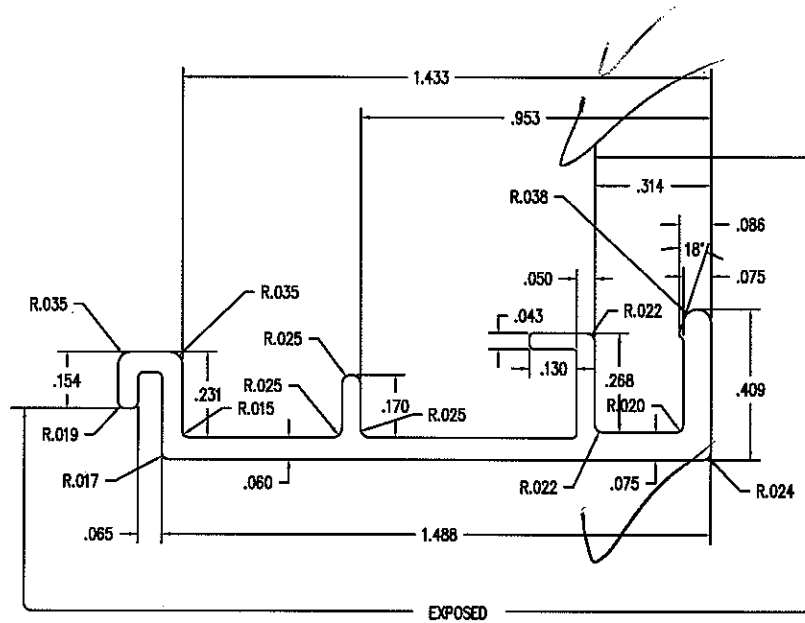

THIS DRAWING AND ITS CONTENTS ARE THE PROPERTY OF EAGLE WINDOW & DOOR. NO USE OR REPRODUCTION OF THE CONTENTS OF THIS DOCUMENT IS PERMITTED WITHOUT THE EXPRESS WRITTEN PERMISSION OF EAGLE WINDOW & DOOR.

TITLE:	07 CDHV, CSHV CHECK RAIL
FINISH:	EAGLE'S STD. COLORS
MATL:	6063 - T6 ALUMINUM
DFT:	ksmith
DCN:	0881
SCALE:	2=1
DRWG:	A72W

NOI	DESCRIPTION	DFT	DOC	DATE
				DATE: 1/29/2007

- NOTE: 1. UNLESS OTHERWISE SPECIFIED, ALL DIMENSIONS SHOWN ARE IN INCHES AND ALL TOLERANCES ARE TO BE: DEC. ± 0.005 ; FRAC. $\pm 1/64$; ANGLES $\pm 1/2^\circ$.
 2. WALL THICKNESS TO BE .050 UNLESS OTHERWISE SPECIFIED.
 3. RADIUS TO BE .016 UNLESS OTHERWISE SPECIFIED.

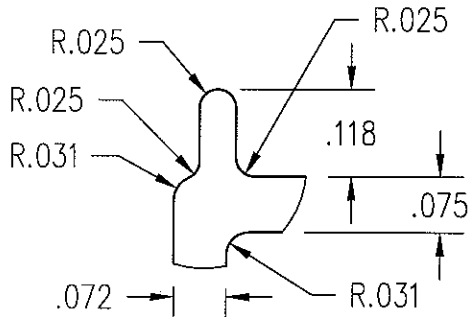

DETAIL B
SCALE X 2

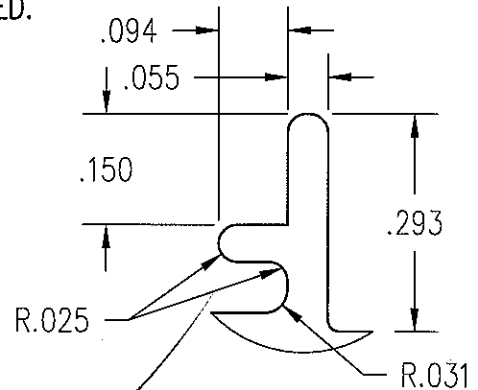

DETAIL A
SCALE X 2

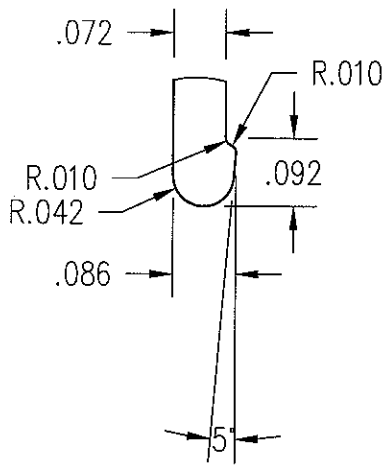
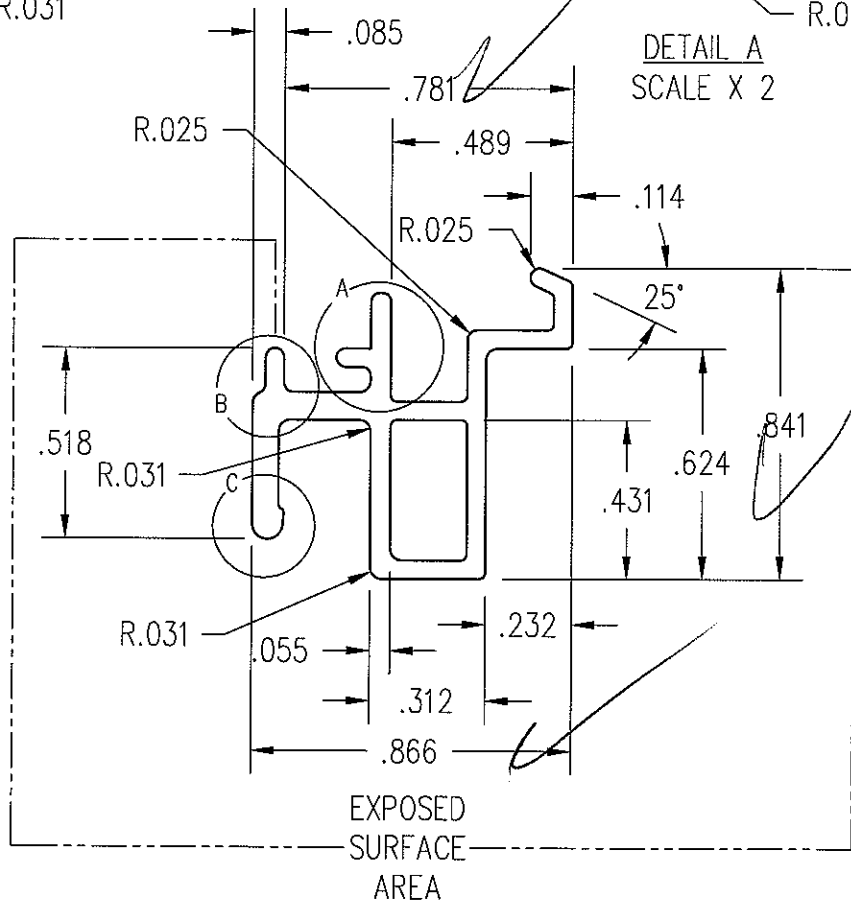

DETAIL C
SCALE X 2



Architectural Testing

Test sample complies with these details:
 Deviations are noted:

Report# 73120
 Date 5/29-6/1/07 Tech TG

THIS DRAWING AND ITS CONTENTS ARE THE PROPERTY OF EAGLE WINDOW & DOOR. NO USE OR REPRODUCTION OF THE CONTENTS OF THIS DOCUMENT IS PERMITTED WITHOUT THE EXPRESS WRITTEN PERMISSION OF EAGLE WINDOW & DOOR.

TITLE: '07 CDHV
 BOTTOM CHECK RAIL

FINISH: EAGLE'S STD. COLORS

MATL: 6063 - T6 ALUMINUM

DFT: ksmith SCALE: 2=1

DCN: 0881 DRWG: A72X

DATE: 1/29/2007 A 01 OF 02

NO	DESCRIPTION	DFT	DOC	DATE

- NOTE: 1. UNLESS OTHERWISE SPECIFIED, ALL DIMENSIONS SHOWN ARE IN INCHES AND ALL TOLERANCES ARE TO BE: DEC. $\pm .010$; FRAC. $\pm 1/64$; ANGLES $\pm 1/2^\circ$.
 2. TYPICAL WALL THICKNESS $.050$.
 3. UNSPECIFIED RADIUS TO BE $.010$.
 4. AREA = $.287$ SQ. IN.

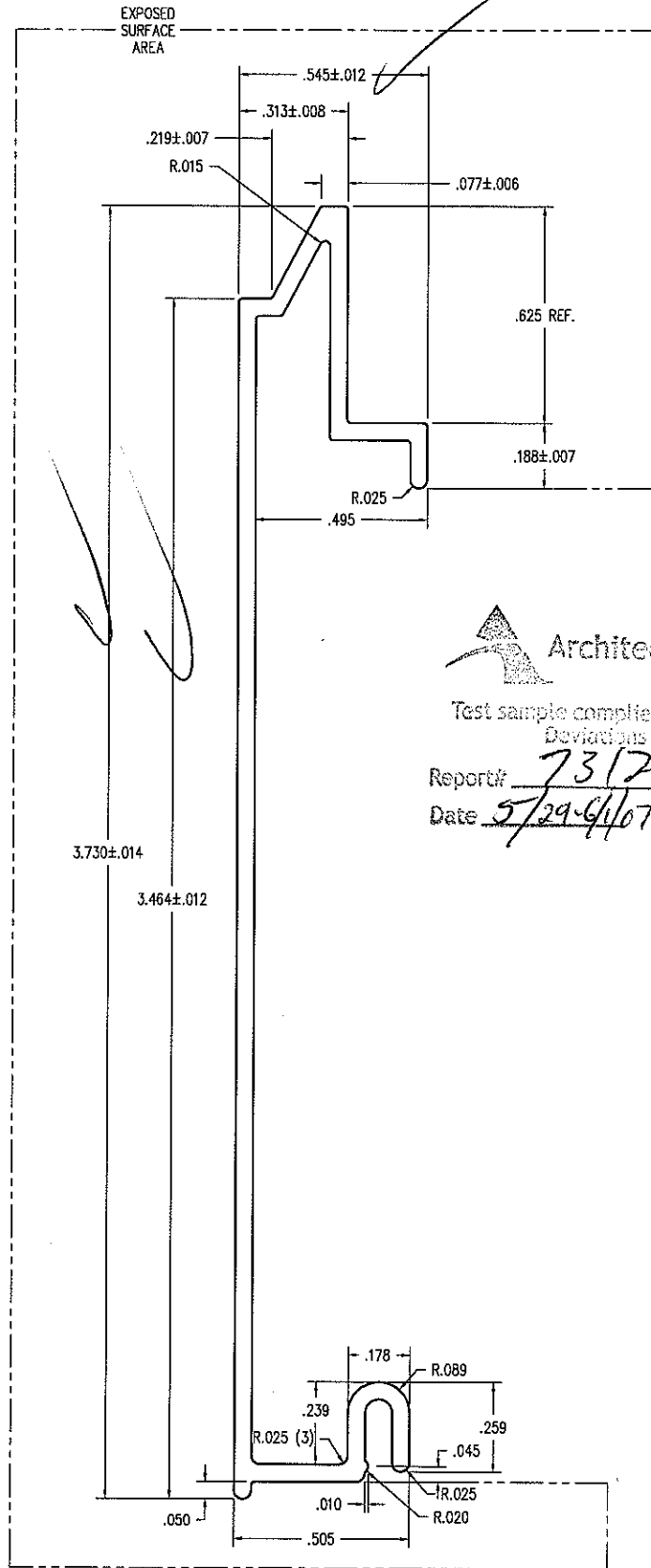

Architectural Testing

Test sample complies with these details.
 Deviations are noted.

Report# 73170
 Date 5/29-6/1/07 Tech TC

THIS DRAWING AND ITS CONTENTS ARE THE PROPERTY OF EAGLE WINDOW & DOOR. NO USE OR REPRODUCTION OF THE CONTENTS OF THIS DOCUMENT IS PERMITTED WITHOUT THE EXPRESS WRITTEN PERMISSION OF EAGLE WINDOW & DOOR.
 TITLE: 107 CDHV, CDHF
 LOWER RAIL COVER
 FINISH: EAGLE'S STD. COLORS
 MATL: 6063 T-6 ALUMINUM

01	CHANGED PROFILE	TWN	PRE	12/12/06	DCN:	0881	DRWG:	A71X
NO	DESCRIPTION	DFT	DOC	DATE	DATE:	1/29/2007	C	01 OF 02

- NOTE: 1. UNLESS OTHERWISE SPECIFIED, ALL DIMENSIONS SHOWN ARE IN INCHES AND ALL TOLERANCES ARE TO BE: DEC. $\pm .005$; FRAC. $\pm 1/64$; ANGLES $\pm 1/2^\circ$.
2. UNLESS OTHERWISE SPECIFIED, WALL THICKNESS IS .045
3. UNLESS SPECIFIED, BREAK ALL CORNERS .015.
4. PROFILE AREA = .075 SQ. IN.
5. SHG (L) = AFH/2 - 1.188.
- SHG COTT. (L) = AFH/2 + 4.812.
- SHG REV. COTT. (L) = AFH/2 - 7.188.

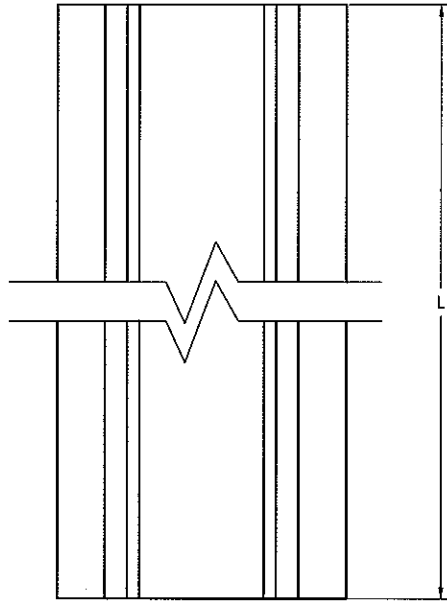

DOUBLE HUNG	
FRAME HEIGHT	L
36	0
40	0
48	0
54	0
60	0
66	12
72	12
78	12
84	12
90	24

SINGLE HUNG	
FRAME HEIGHT	L
36	16 13/16
40	18 13/16
48	22 13/16
54	25 13/16
60	28 13/16
66	31 13/16
72	34 13/16
78	37 13/16
84	40 13/16
90	43 13/16

DH COTT.	
FRAME HEIGHT	L
36	0
40	0
48	0
54	14
60	14
66	14
72	14
78	14
84	14
90	24

DH REV. COTT.	
FRAME HEIGHT	L
36	0
40	0
48	0
54	0
60	0
66	0
72	12
78	12
84	12
90	12

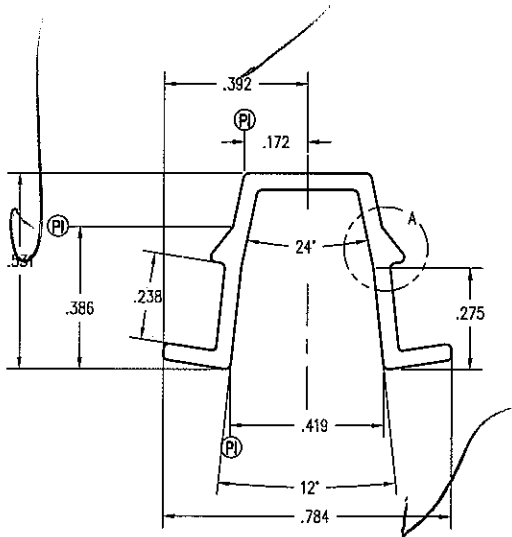

3

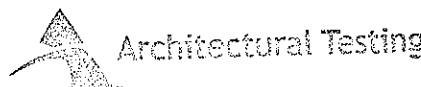
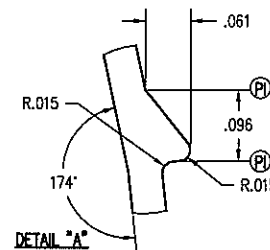

Test sample complies with these details.
Deviations are noted.

Report# 73/20
Date 5/29-4/1/03 Tech TG

PVC TOLERANCES	
.000-.125	$\pm .010$
.125-.500	$\pm .015$
.500-2.00	$\pm .020$
2.00-4.00	$\pm .030$
4.00-5.00	$\pm .040$
WALLS	$\pm .005$
ANGLES	$\pm 3^\circ$

THIS DRAWING AND ITS CONTENTS ARE THE PROPERTY OF EAGLE WINDOW & DOOR. NO USE OR REPRODUCTION OF THE CONTENTS OF THIS DOCUMENT IS PERMITTED WITHOUT THE EXPRESS WRITTEN PERMISSION OF EAGLE WINDOW & DOOR.

TITLE: CDHW/WDHW
SASH STOP
FINISH: BEIGE, WHITE

MATL: RIGID PVC

03 CHGD LENGTHS TO 14"	TWN TRKR 10/20/05				
02 CORRECT 78" SHG (L)	AWW 0844 1/22/04	DFT:	AWW	SCALE:	2=1
01 FLARED LEGS APART	PJST 0805 7/9/03	DCN:	0589	DRWG:	A52F
NO. DESCRIPTION	DFT	DOC	DATE	DATE:	2/4/2002 C 01 OF 01

- NOTE: 1. UNLESS OTHERWISE SPECIFIED, ALL DIMENSIONS SHOWN ARE IN INCHES AND ALL TOLERANCES ARE TO BE: DEC. ± 0.005 ; FRAC. $\pm 1/64$; ANGLES $\pm 1/2^\circ$.
 2. ALL NON LABELED RADIUS ARE .020.
 3. L = AFW - 3 13/16".



Architectural Testing

Test sample complies with these details.
 Deviations are noted.

Report# 73120
 Date 5/29-6/1/07 Tech TG

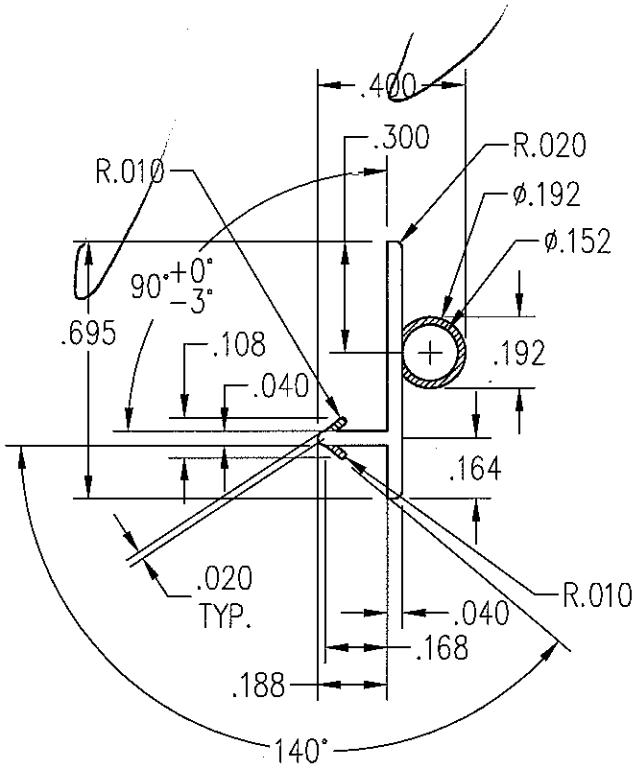
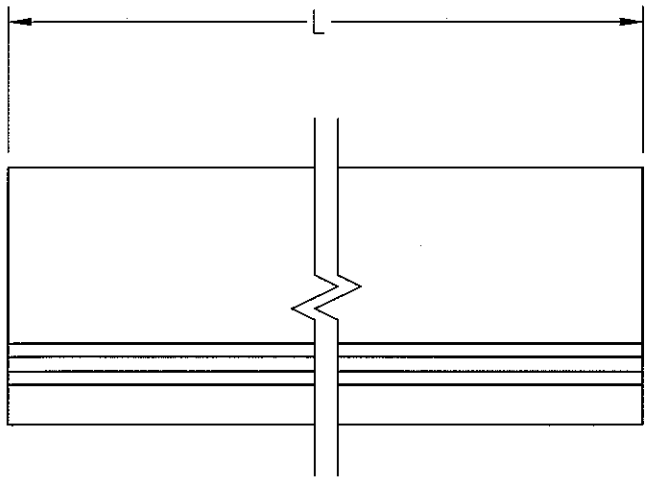

THIS DRAWING AND ITS CONTENTS ARE THE PROPERTY OF EAGLE WINDOW & DOOR. NO USE OR REPRODUCTION OF THE CONTENTS OF THIS DOCUMENT IS PERMITTED WITHOUT THE EXPRESS WRITTEN PERMISSION OF EAGLE WINDOW & DOOR.

TITLE: '07 CDHV
 CR WEATHERSTRIP

FINISH: BEIGE

MATL: DUAL DURAMETER / VINYL

DFT: ksmith SCALE: 2=1

01	CHANGED BULB SIZE	TWN	PRE	3/20/07	DCN: 0881	DRWG: A72T
NO	DESCRIPTION	DFT	DOC	DATE	DATE: 1/29/2007	A 01 OF 01

NOTE: 1. UNLESS OTHERWISE SPECIFIED, ALL DIMENSIONS SHOWN ARE IN INCHES AND ALL TOLERANCES ARE TO BE: DEC. ± 0.005 ; FRAC. $\pm 1/64$; ANGLES $\pm 1/2^\circ$.



Architectural Testing

Test sample complies with these details.
Deviations are noted.

Report# 73120
Date 5/29-6/1/07 Tech TG

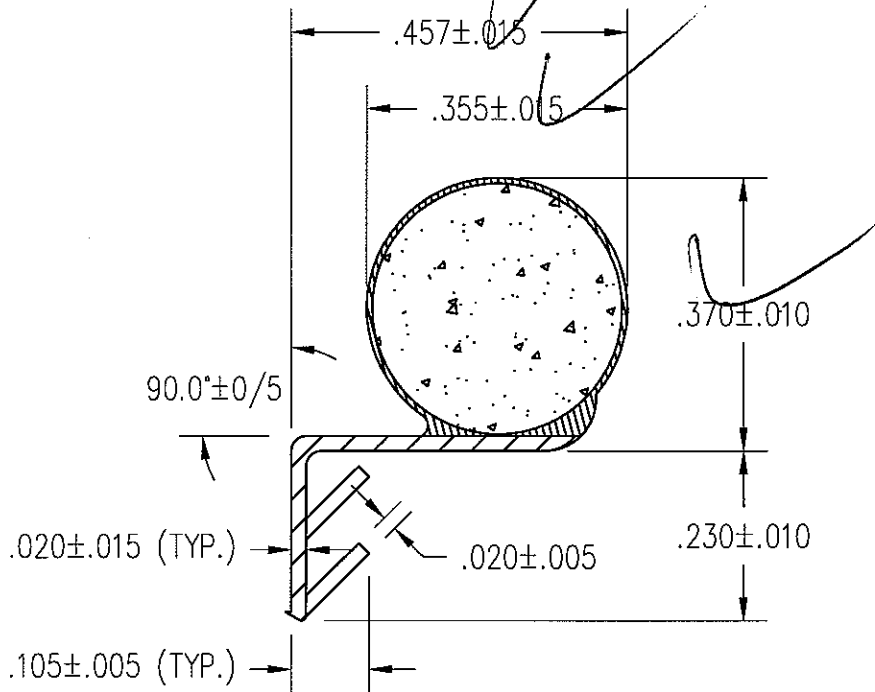

THIS DRAWING AND ITS CONTENTS ARE THE PROPERTY OF EAGLE WINDOW & DOOR. NO USE OR REPRODUCTION OF THE CONTENTS OF THIS DOCUMENT IS PERMITTED WITHOUT THE EXPRESS WRITTEN PERMISSION OF EAGLE WINDOW & DOOR.

TITLE: DH HEAD WEATHERSTRIP

FINISH:

MATL:

DFT: RJW

SCALE: 4=1

DCN: 0498

DRWG: A43G

DATE: 9/28/00

A 01 OF 02

NO	DESCRIPTION	DFT	DOC	DATE

NOTE: 1. UNLESS OTHERWISE SPECIFIED, ALL DIMENSIONS SHOWN ARE IN INCHES AND ALL TOLERANCES ARE TO BE: DEC. ± 0.005 ; FRAC. $\pm 1/64$; ANGLES $\pm 1/2^\circ$.
 2. L = AFW - 3.800.



Architectural Testing

Test sample complies with these details.
 Deviations are noted.

Report# 73170
 Date 5/29-6/16/07 Tech TG

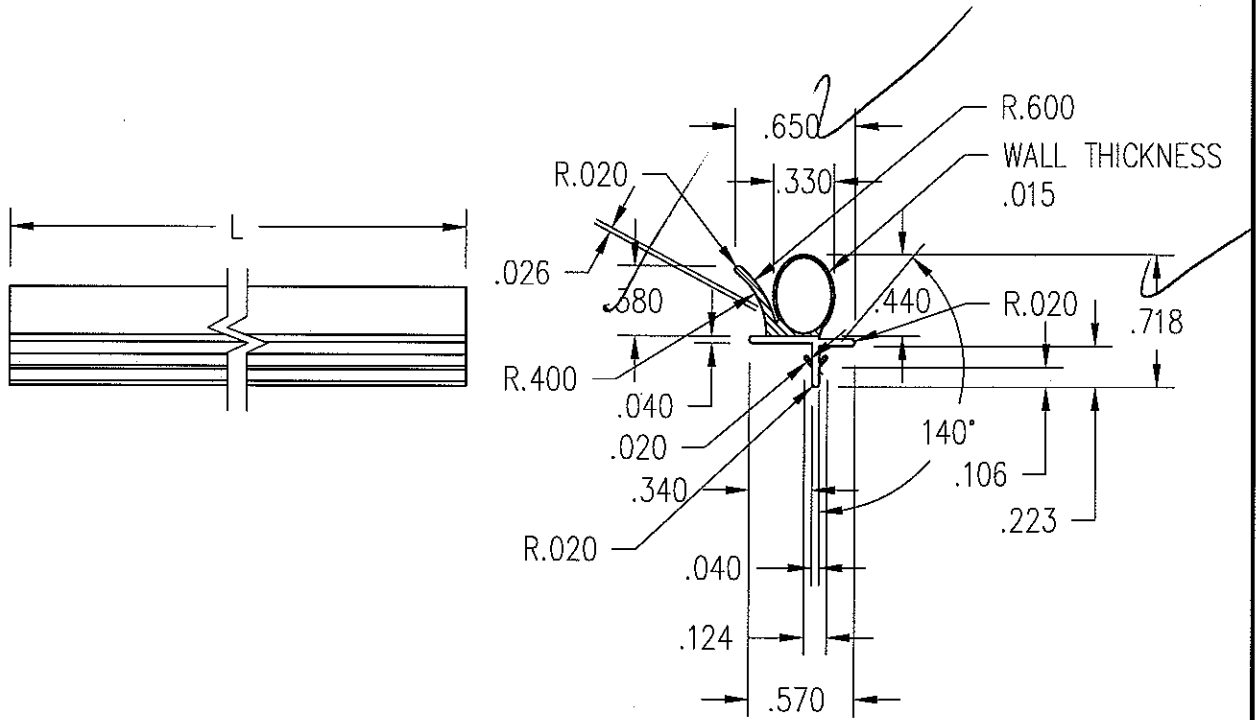

THIS DRAWING AND ITS CONTENTS ARE THE PROPERTY OF EAGLE WINDOW & DOOR. NO USE OR REPRODUCTION OF THE CONTENTS OF THIS DOCUMENT IS PERMITTED WITHOUT THE EXPRESS WRITTEN PERMISSION OF EAGLE WINDOW & DOOR.	
TITLE: '07 CDHV BULB W-STRIP	
FINISH:	
MATL:	
DFT: ksmith	SCALE: 1=1
DCN: 0881	DRWG: A72G
DATE: 1/29/2007	A 01 OF 01

01	CHANGED PROFILE	TWN	PRE	3/20/07
NO	DESCRIPTION	DFT	DOC	DATE

- NOTE: 1. UNLESS OTHERWISE SPECIFIED, ALL DIMENSIONS SHOWN ARE IN INCHES AND ALL TOLERANCES ARE TO BE: DEC. $\pm .005$; FRAC. $\pm 1/64$; ANGLES $\pm 1/2^\circ$.
2. (4) PCS./UNIT REQ'D. -- (2) TOP (EXT.), (2) BOTTOM (INT.).
3. UPPER SASH: $DH L = AFH/2 - 2"$.
 LOWER SASH: $DH L = AFH/2 + 11/32"$.
4. CSD USES BEIGE, (L) = $AFH - 1 7/8"$
5. COMPRESSION SPECIFICATION
- A) 4.5 LBS ± 1 LB @ 25% COMPRESSION (.084")
 - B) .2 LBS PRE-LOAD
 - C) 4.000" PIECE $\pm .020"$

DOUBLE HUNG		
FRAME HEIGHT	UPPER SASH L	LOWER SASH L
36	16	18 11/32
40	18	20 11/32
48	22	24 11/32
54	25	27 11/32
60	28	30 11/32
66	31	33 11/32
72	34	36 11/32
78	37	39 11/32
84	40	42 11/32
90	43	45 11/32
96	46	48 11/32
102	49	51 11/32
108	52	54 11/32
114	55	57 11/32
120	58	60 11/32

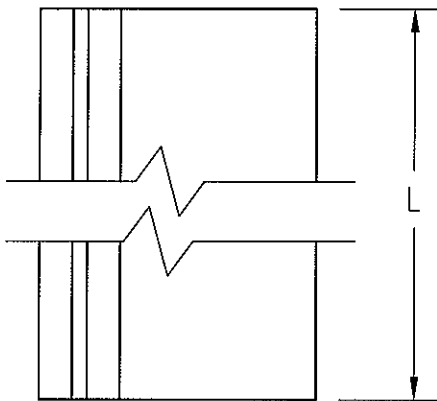
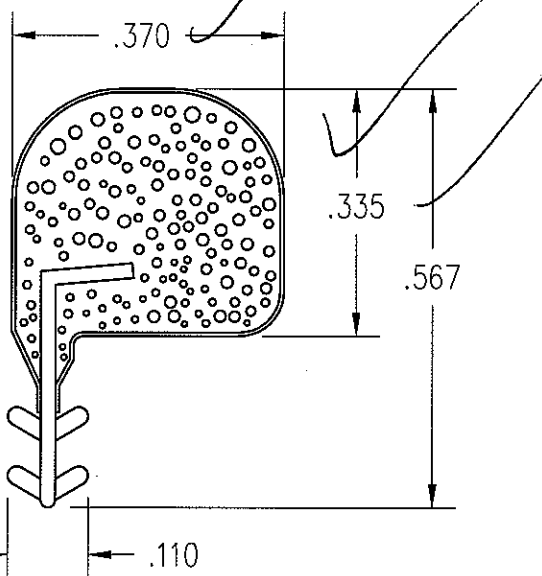

CSD (INTERLOCK)	
FRAME HEIGHT	L
80	78 1/8
82	80 1/8
96	94 1/8
120	118 1/8

THIS DRAWING AND ITS CONTENTS ARE THE PROPERTY OF EAGLE WINDOW & DOOR. NO USE OR REPRODUCTION OF THE CONTENTS OF THIS DOCUMENT IS PERMITTED WITHOUT THE EXPRESS WRITTEN PERMISSION OF EAGLE WINDOW & DOOR.

TITLE: DHG JAMB WEATHER STRIP
 SCHLEGEL (LAMINATED LINER)

FINISH:

MATL: CORE: HR URETHANE FOAM
 SKIN: PE LINER M5

03	UPDATED DHG CHART & NOTE #3	KJS	0881	1/5/07		
02	ADD COMPRESSION SPEC	PJB	0873	4/6/2004	DFT: AWW	SCALE: 4=1
01	ADD CSD CHART	AWW	0743	2/17/2003	DCN: 0589	DRWG: A523
NO	DESCRIPTION	DFT	DOC	DATE	DATE: 8/23/2001	A 01 OF 01

Architectural Testing
 Test sample complies with these details.
 Report# 73120
 Date 5/29/07 Tech TG