

**AAMA/WDMA/CSA  
TEST REPORT**

**Rendered to:**

**EAGLE WINDOW & DOOR, INC.**

**SERIES/MODEL: 3-4 x 8-6 Series 05 Clad Ascent Inswing French Door**

**PRODUCT TYPE: Aluminum Clad In-Swing Door**

<b>Title</b>	<b>Summary of Results</b>
101/I.S.2.NAFS-02	HGD-C45 1016 x 2591 (40 x 102)
AAMA/WDMA/CSA 101/I.S.2/A440-05	SHD-C45 1016 x 2591 (40 x 102)
AAMA/WDMA/CSA 101/I.S.2/A440-08	CW-PG45-SHD 1016 x 2591 (40 x 102)
Design Pressure	2400 Pa (50.0 psf)
Negative Design Pressure	3120 Pa (65.0 psf)
Air Infiltration	1.52 L/s/m <sup>2</sup> (0.06 cfm/ft <sup>2</sup> )
Water Penetration Resistance Test Pressure	330 Pa (6.75 psf)
Uniform Load Structural Test Pressure	+3600, -4680 Pa (+75.0, -97.5 psf)
Forced Entry Resistance	Pass

**Test Completion Date:** 07/10/08

Reference must be made to Report No. 82743.01-201-44 dated 08/12/08 for complete test specimen description and data.



Architectural Testing

**AAMA/WDMA/CSA TEST REPORT**

Rendered to:

EAGLE WINDOW & DOOR, INC.  
2045 Kerper Boulevard  
Dubuque, Iowa 52004-1072

Report No.: 82743.01-201-44  
Test Date: 05/05/08  
Through: 07/10/08  
Original Report Date: 07/16/08  
Revised Report Date: 08/12/08  
Expiration Date: 05/05/12

**Project Summary:** Architectural Testing, Inc. was contracted by Eagle Window & Door, Inc. to perform testing on a 3-4 x 8-6 Series 05 Clad Ascent Inswing French Door, Aluminum Clad In-Swing Door in Architectural Testing, Inc. test facility in St. Paul, Minnesota. The sample tested successfully met the performance requirements per 101/I.S.2.NAFS-02 to an HGD-C45 1016 x 2591 (40 x 102); AAMA/WDMA/CSA 101/I.S.2/A440-05 to a SHD-C45 1016 x 2591 (40 x 102) rating and per AAMA/WDMA/CSA 101/I.S.2/A440-08 to a CW-PG45-SHD 1016 x 2591 (40 x 102) rating. Test specimen description and results are reported herein.

**Test Specification(s):** The test specimen was evaluated in accordance with:

101/I.S. 2/NAFS-02, *Voluntary Performance Specification for Windows, Skylights and Glass Doors.*

AAMA/WDMA/CSA 101/I.S.2/A440-05, *Standard/Specification for Windows, Doors and Unit Skylights.*

AAMA/WDMA/CSA 101/I.S.2/A440-08, *Standard/Specification for Windows, Doors and Unit Skylights.*

**Test Specimen Description:**

**Series/Model:** 3-4 x 8-6 Series 05 Clad Ascent Inswing French Door

**Product Type:** Aluminum Clad In-Swing Door

**Overall Size:** 1016 mm (40") wide by 2591 mm (102") high

**Panel Size:** 970 mm (38-3/16") wide by 2519 mm (99-3/16") high

**Overall Area:** 2.6 m<sup>2</sup> (28.3 ft<sup>2</sup>)

**Finish:** Interior wood was natural and the exterior aluminum cladding was white.

**Test Specimen Description:** (Continued)

**Frame Construction:** The sill was coped, butted and secured to the jamb utilizing two #8 by 64 mm (2-1/2") screws through sill through plastic corner keys and into wood jamb. The exterior cladding was secured with one #8 by 25 mm (1") screw per corner. The jamb was coped, butted and secured through the head with two #8 by 44 mm (1-3/4") screws. The exterior cladding was secured with two #8 by 11 mm (7/16") screws, one #6 by 32 mm (1-1/4") screw through a plastic corner key per corner.

**Panel Construction:** The wood stiles and rails were joined by two 19 mm by 102 mm (3/4" by 4") hardwood dowels. Extruded aluminum cladding was square-cut and butted at the corners, sealed with silicone or butyl tape and secured with a corner key.

**Weatherstripping:**

<u>Description</u>	<u>Quantity</u>	<u>Location</u>
Q-Lon	1 Row	Perimeter of panel at Head and side jambs
Foam filled PVC w/ leaf	1 Row	Sill below panel
6 mm (1/4") Diameter Hollow bulb	1 Row	Bottom of panel bottom rail
Vinyl wrapped foam pad	2	Sill corners

**Glazing Details:** The window utilized a nominal 19 mm (3/4") thick insulating glass fabricated from two sheets of nominal 3.1 mm (1/8") tempered glass separated by an aluminum spacer system. The glass was set from the interior against hot melt silicone. Wood glazing stops with single sided adhesive foam tape were utilized on the interior and secured with 12 mm (1-1/4") brads spaced 25 mm (1") from each corner and 152 to 203 mm (6" to 8") on center.

**Drainage:**

<u>Description</u>	<u>Quantity</u>	<u>Location</u>
51 mm (1/2") wide by 5 mm (3/16") high weep slot	2	Sill catch basin 203 mm (8") from each end
51 mm (1/2") wide by 3 mm (1/8") high weep slot	2	Exterior sill face at each end of sill

**Test Specimen Description:** (Continued)

**Hardware:**

<u>Description</u>	<u>Quantity</u>	<u>Location</u>
Hinges	4	305 mm (12") from bottom of sill and spaced 610 mm (24") on center
3-pt. Lock assembly and dead bolt with handle	1	Active panel 305 mm (12") from edge of panel and dead bolt at 914 mm (36") from bottom

**Installation:** The test unit was installed within a double wood test buck. The unit was secured through strike plates with seven #8 by 64 mm (2-1/2") screws. Two #10 by 64 mm (2-1/2") screws were utilized through each hinge into test buck. The unit was sealed to the buck with silicone.

**Test Results:** The results are tabulated as follows:

<u>Paragraph</u>	<u>Title of Test - Test Method</u>	<u>Results</u>	<u>Allowed</u>
--	Force to Latch Side-Hinged Door System per ANSI/BHMA A156.2		
5.3.1.2	Force to latch	36 N (8.0 lbf)	Report only
5.3.1.2	Deadbolt	27 N (6.0 lbf)	100 N (22.5 lbf) max.
5.3.2	Air Infiltration per ASTM E 283		
5.3.2	75 Pa (1.57 psf, 25 mph)	1.52 L/s/m <sup>2</sup> (0.06 cfm/ft <sup>2</sup> )	1.5 L/s/m <sup>2</sup> (0.30 cfm/ft <sup>2</sup> ) max.
5.3.2	300 Pa (6.24 psf, 50 mph)	0.76 L/s/m <sup>2</sup> (0.15 cfm/ft <sup>2</sup> )	-- --

**Note #1:** The tested specimen meets (or exceeds) the performance levels specified in 101/I.S.2/NAFS-02, AAMA/WDMA/CSA 101/I.S.2/A440-05 and AAMA/WDMA/CSA 101/I.S.2/A440-08 for air infiltration.

5.3.3	Water Penetration Resistance per ASTM E 547		See Note #2
5.3.3			
5.3.3			
5.3.4.1	Uniform Load Deflection per ASTM E 330		See Note #2
5.3.4.2			
5.3.4.2			

**Test Results:** (Continued)

<u>Paragraph</u>	<u>Title of Test - Test Method</u>	<u>Results</u>	<u>Allowed</u>
5.3.4.2 5.3.4.3 5.3.4.3	Uniform Load Structural per ASTM E 330		See Note #2
<i>Note #2: The client opted to start at a pressure higher than the minimum required. Those results are listed under "Optional Performance."</i>			
5.3.5 5.3.5 5.3.5	Forced Entry Resistance per AAMA 1304 1330 N (300 lbf) point load Top lock stile corner Bottom lock stile corner Above lock	No entry No entry No entry	No entry No entry No entry
-- 5.3.6.10 5.3.6.10	Operation/Cycling Performance per AAMA 920 250,000	Meets as stated	Meets as stated
-- 5.3.6.11 5.3.6.11	Vertical Loading Resistance per AAMA 925 Pre-load - 200 N (45 lbf) Maximum vertical deflection Residual vertical deflection Test load - 675 N (150 lbf) Maximum vertical deflection Residual vertical deflection Diagonal deformation Force to latch	0.3 mm (0.01") <0.3 mm (<0.01") 2.8 mm (0.11") 0.8 mm (0.03") <0.3 mm (<0.01") 40 N (9.0 lbf)	N/A N/A N/A N/A N/A Report only
<u>Optional Performance</u>			
4.2.2.5 4.4.2.6 4.3.2	Water Resistance per ASTM E 547 330 Pa (6.75 psf)	No leakage	No leakage
4.2.2.5 4.4.2.6 4.3.2	Uniform Load Deflection per ASTM E 330 (Loads were held for 60 seconds) (Deflections reported were taken on the panel stile) 2400 Pa (50.0 psf) (positive) 3120 Pa (65.0 psf) (negative)	1.3 mm (0.05") 2.0 mm (0.08")	5.84 mm (0.23") 5.84 mm (0.23")

*Note #3: The deflections reported are not limited by 101/I.S.2/NAFS-02, AAMA/WDMA/CSA 101/I.S.2/A440-05 or AAMA/WDMA/CSA 101/I.S.2/A440-08 for this product designation. The deflection data is recorded in this report for special code compliance and information only.*

**Test Results:** (Continued)

<u>Paragraph</u>	<u>Title of Test - Test Method</u>	<u>Results</u>	<u>Allowed</u>
4.2.2.5	Uniform Load Structural per ASTM E 330		
4.4.2.6	(Loads were held for 10 seconds)		
4.3.2	(Permanent sets reported were taken on the panel stile)		
	3600 Pa (75.0 psf) (positive)	0.3 mm (0.01")	3.05 mm (0.12") max.
	4680 Pa (97.5 psf) (negative)	0.5 mm (0.02")	3.05 mm (0.12") max.

Tape and film were used to seal against air leakage during structural testing. In our opinion, the tape and film did not influence the results of the test.

**Drawing Reference:** The test specimen drawings have been reviewed by Architectural Testing, Inc. and are representative of the test specimen reported herein.

**List of Official Observers:**

<u>Name</u>	<u>Company</u>
Tony D. Gavin	Architectural Testing, Inc.
Karl A. Lips-Eakins	Architectural Testing, Inc.

Detailed drawings, data sheets, representative samples of test specimens, a copy of this report, or other pertinent project documentation will be retained by Architectural Testing, Inc. for a period of four years from the original test date. At the end of this retention period, such materials shall be discarded without notice and the service life of this report will expire.

Results obtained are tested values and were secured by using the designated test methods. No conclusions of any kind regarding the adequacy or inadequacy of the glass in the test specimen can be made. This report does not constitute certification of this product nor an opinion or endorsement by this laboratory. It is the exclusive property of the client so named herein and relates only to the specimens tested. This report may not be reproduced, except in full, without the written approval of Architectural Testing, Inc.

For ARCHITECTURAL TESTING, INC.

---

Eric J. Schoenthaler  
Project Manager

---

Daniel A. Johnson  
Director - Regional Operations

EJS/mb

Attachments (Pages): This report is complete only when all attachments listed are included.

- Appendix A: Alteration Addendum (1)
- Appendix B: WDMA Submittal Forms (2)
- Appendix C: Drawings (21)

### Revision Log

<u>Rev. #</u>	<u>Date</u>	<u>Page(s)</u>	<u>Revision(s)</u>
0	07/16/08	N/A	Original report issue. Report and drawings forwarded to AMS for Hallmark Certification.
1	08/12/08	2	Corrected frame construction and sash construction. Report and drawings forwarded to AMS for Hallmark Certification.

**APPENDIX A**

**Alteration Addendum**

*Note: No alterations were required.*

**APPENDIX B**  
**WDMA Submittal Forms**



# WDMA HALLMARK CERTIFICATION PROGRAM REPORT SUBMISSION FORM

THIS FORM IS TO BE COMPLETED BY THE MANUFACTURER AND SUBMITTED TO AMS PRIOR TO OR ALONG WITH SUBMISSION OF EACH NEW OR REVISED TEST REPORT FOR CERTIFICATION TO THE HALLMARK PROGRAM. ANY QUESTIONS PLEASE CONTACT AMS AT 315-646-2234 OR [staff@amscert.com](mailto:staff@amscert.com).

Manufacturer: Eagle Windows and Doors

Contact: Chad Cornell

Plant Location(s):  
(list all plants where product is made)  
2045 Kerper Blvd. Dubuque, IA 52001

Phone: 1-800-324-5354 ext#456

Test Report #: 82743.01-201-44

Email: [chad.cornell@eaglewindow.com](mailto:chad.cornell@eaglewindow.com)

### Product Relationship:

Extension of currently certified product ?  yes  no  n/a      Recertification  New  (check one)

If yes, what CCL # ? 54367.02-201-44

Difference from Certified Product: 6" taller

Is this a Gateway Test ?  yes  no  n/a

Does this report require a Gateway Report # ?  yes  no  n/a      Report #: \_\_\_\_\_

### Impact Report:

If this is not an impact report check here:

AWS Report # \_\_\_\_\_

Test Plan # ?  yes  no  n/a \_\_\_\_\_

Installation Instructions submitted ?  yes  no  n/a

### Certification to Florida:

If this will not be submitted to Florida check here:

AMS to Input to Database  yes  no  n/a

Manufacturer to input  yes  no  n/a



# WDMA HALLMARK CERTIFICATION PROGRAM REPORT SUBMISSION FORM

Product Name: Ascent Series 05 Clad Inswing French Door Vent Single SP1  
(as to be listed on CCL)

Product Type: Clad Hinged Door Vent

Additional Manufacturer ID #: \_\_\_\_\_

■ n/a

<u>Hallmark CCL</u>	<u>Standard</u>	<u>Rating</u>
<input type="checkbox"/>	ANSI/AAMA/NWWDA 101/I.S. 2 97	_____
<input type="checkbox"/>	101/I.S.2/NAFS-02	HGD-C45 1016 x 2591 (40 x 102)
<input checked="" type="checkbox"/>	AAMA/WDMA/CSA/101/I.S.2/A440-05	SHD-C45 1016 x 2591 (40 x 102)
<input type="checkbox"/>	ASTM E 1996 99 / E1886-97	_____
<input type="checkbox"/>	ASTM E 1996 01 / E1886-97	_____
<input type="checkbox"/>	ASTM E 1996 02 / E1886-02	_____
<input type="checkbox"/>	ASTM E 1996 03 / E1886-02	_____
<input type="checkbox"/>	ASTM E 1996 04 / E1886-04	_____
<input type="checkbox"/>	ASTM E 1996 05 / E1886-05	_____
<input type="checkbox"/>	ASTM E330 02	_____
<input type="checkbox"/>	ANSI A250.13-03	_____
<input type="checkbox"/>	TAS 201-94	_____
<input type="checkbox"/>	TAS 202-94	_____
<input type="checkbox"/>	TAS 203-94	_____
<input checked="" type="checkbox"/>	Other: AAMA/WDMA/CSA/101/I.S.2/A440-08	CW-PG45-SHD 1016 x 2591 (40 x 102)

**Appendix C**

**Drawings**

1. (7 OR 9) #8 x 2 1/2" SCREWS THROUGH STRIKE PLATE INTO BUCK.
2. (8) #10 x 2 1/2" SCREWS THROUGH HINGES INTO BUCK. (2 PER HINGE, 8 TOTAL PER SIDE)

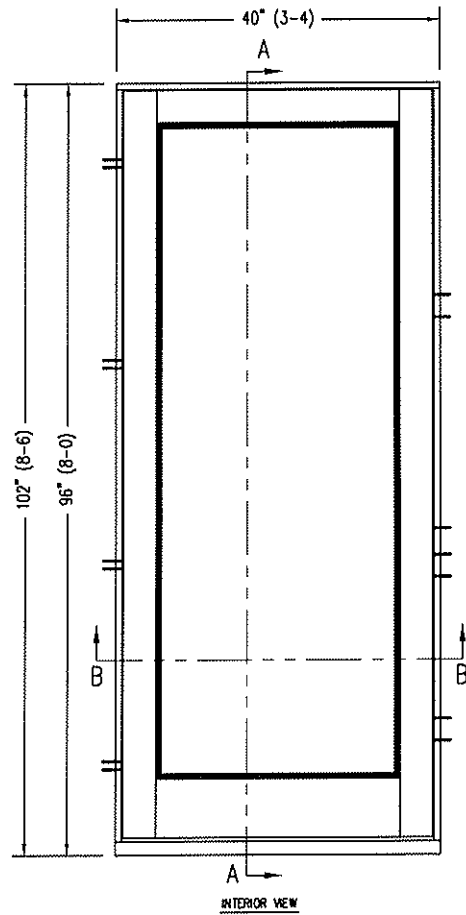
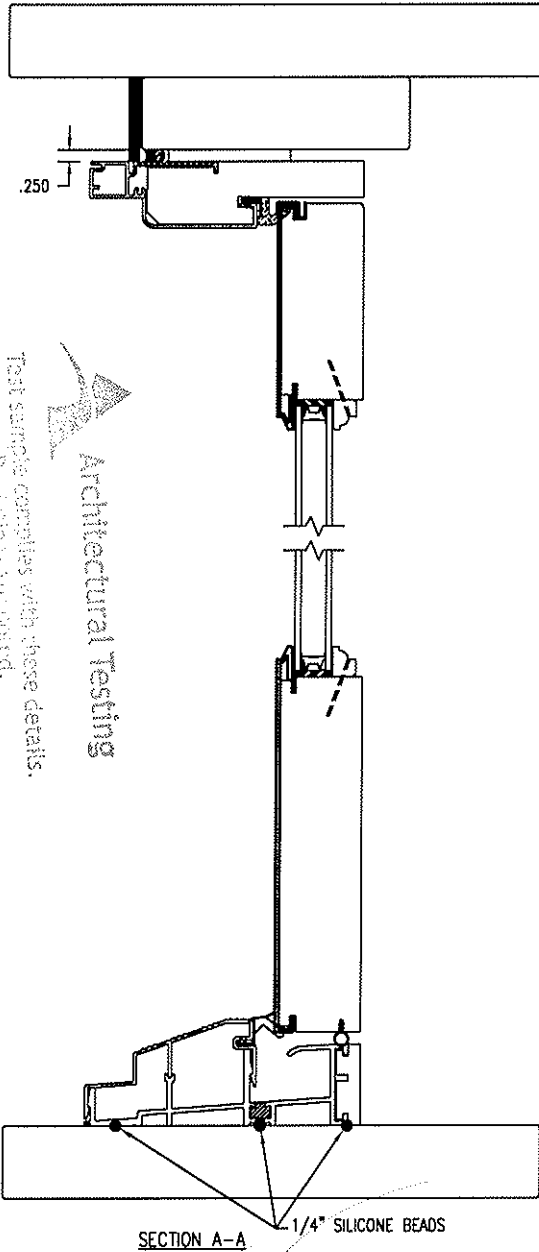
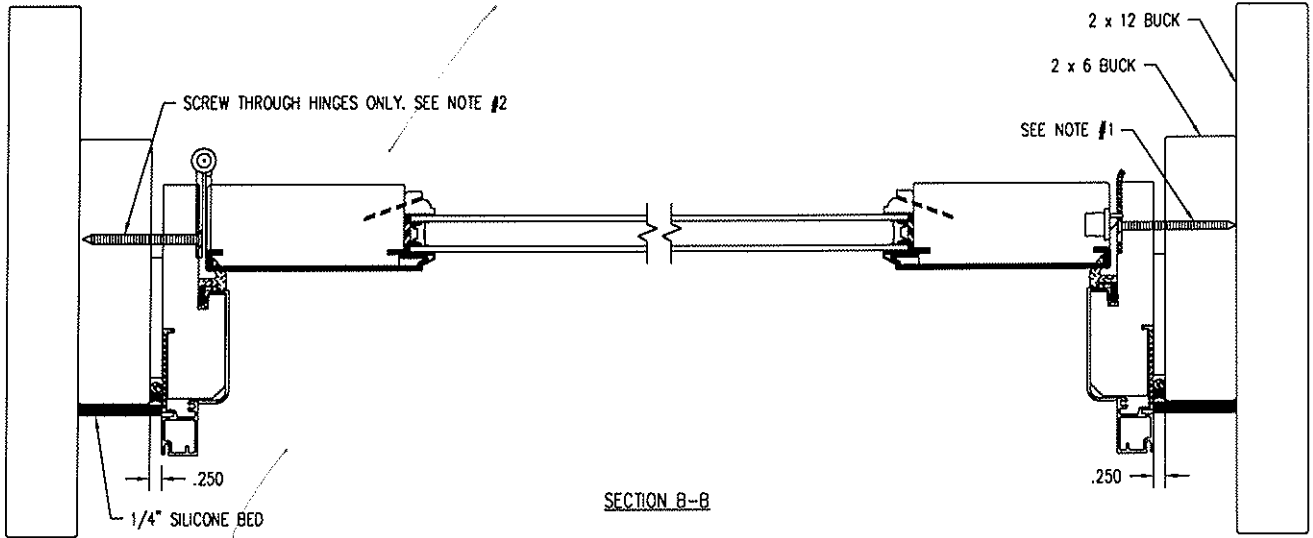

Reports: 8-5-73, 8-2-74  
 Date: 6/12/08 Tech: TG  
 Test sample complies with these details.  
 Deviations are noted.  
**Architectural Testing**

THIS DRAWING AND ITS CONTENTS ARE THE PROPERTY OF EAGLE WINDOW & DOOR. NO USE OR REPRODUCTION OF THE CONTENTS OF THIS DOCUMENT IS PERMITTED WITHOUT THE EXPRESS WRITTEN PERMISSION OF EAGLE WINDOW & DOOR.			
TITLE: CLAD I/S DOOR (4 9/16") INSTALLATION DETAIL			
FINISH:			
MATERIAL:			
DFT:	030188	SCALE:	1=4
DCN:	0710	DRWG:	056J
DATE:	4/1/08	C	01 OF 02

NO	DESCRIPTION	DFT	DOC	DATE

NOTE: 1. A DUST COVER IS PLACED UNDER EACH STRIKE PLATE.

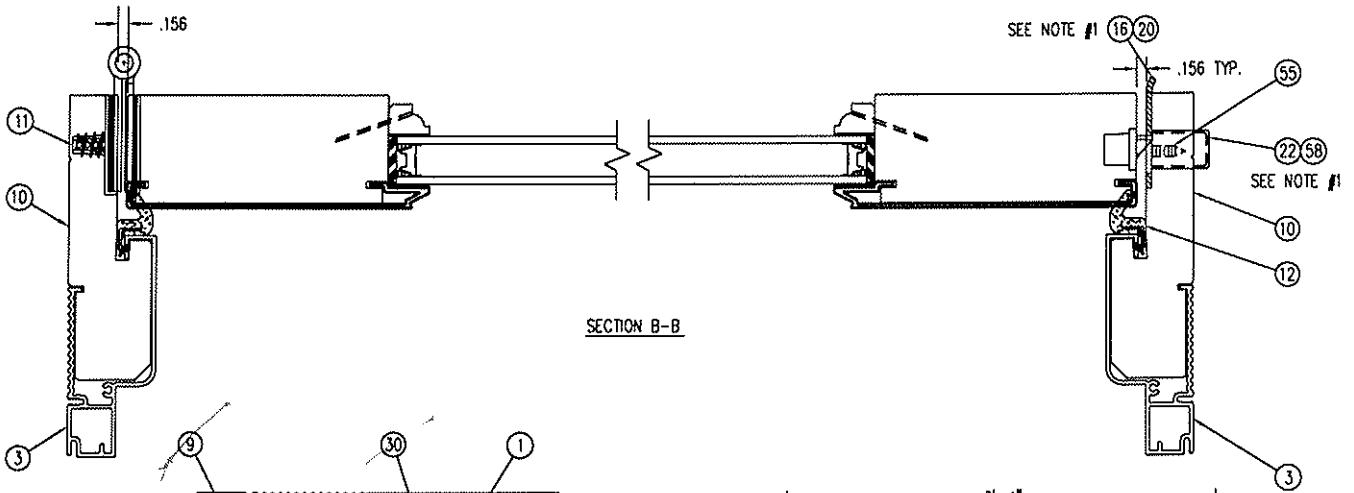

SECTION B-B

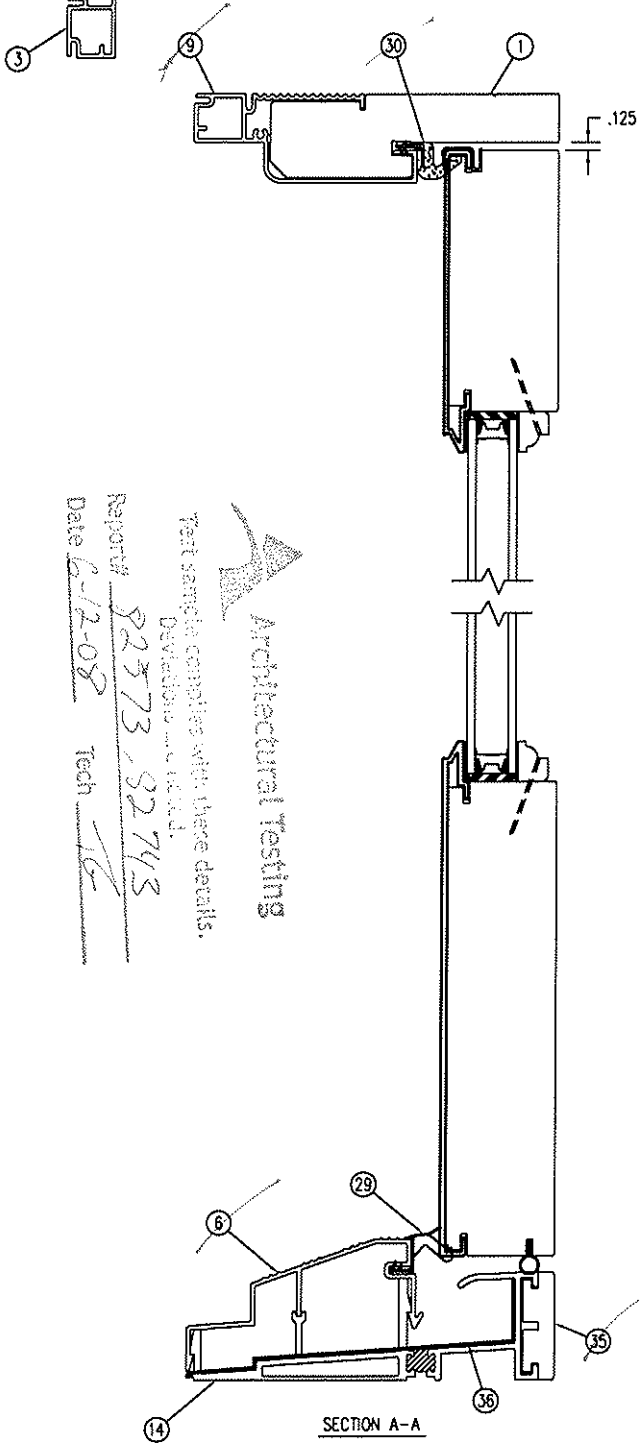

SECTION A-A

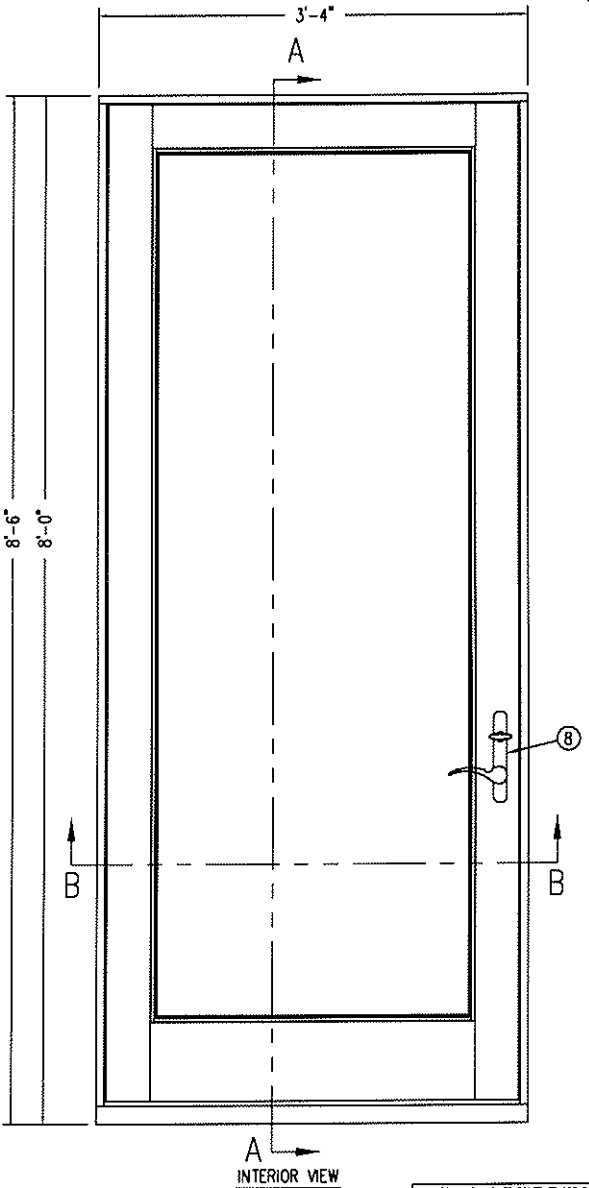

INTERIOR VIEW

Architectural Testing  
 Test sample complies with these details.  
 Deviations ...  
 Report# 82573, 82743  
 Date 6/2-08 Tech *[Signature]*

THIS DRAWING AND ITS CONTENTS ARE THE PROPERTY OF EAGLE WINDOW & DOOR. NO USE OR REPRODUCTION OF THE CONTENTS OF THIS DOCUMENT IS PERMITTED WITHOUT THE EXPRESS WRITTEN PERMISSION OF EAGLE WINDOW & DOOR.

TITLE: CAFDI - SINGLE DOOR  
 (4 9/16" WALL) UNIT ASSEMBLY

FINISH:

MATL:

DFT: 030648	SCALE: 1=3
DCN: 0710	DRWG: 056G
DATE: 3/25/2008	C 01 OF 09

NO	DESCRIPTION	DFT	DOC	DATE

NOTE: ALL SCREW LOCATIONS TYPICAL.

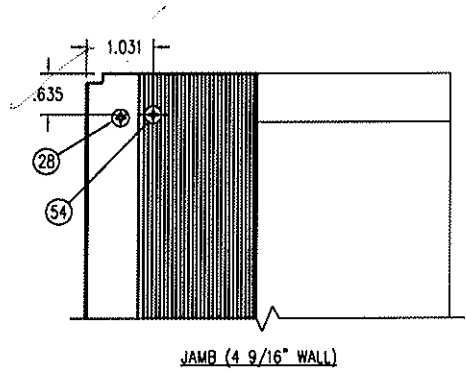
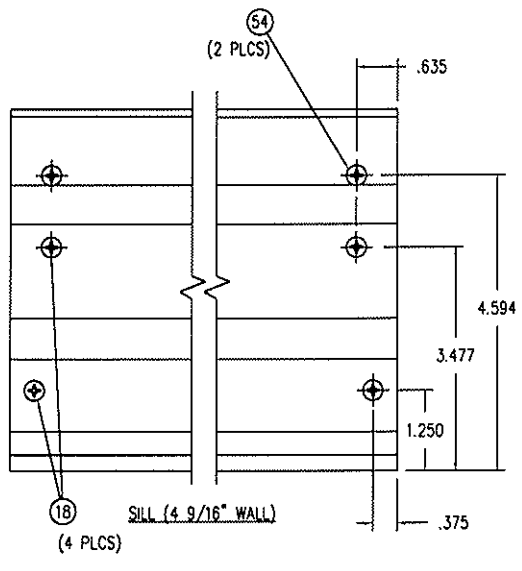
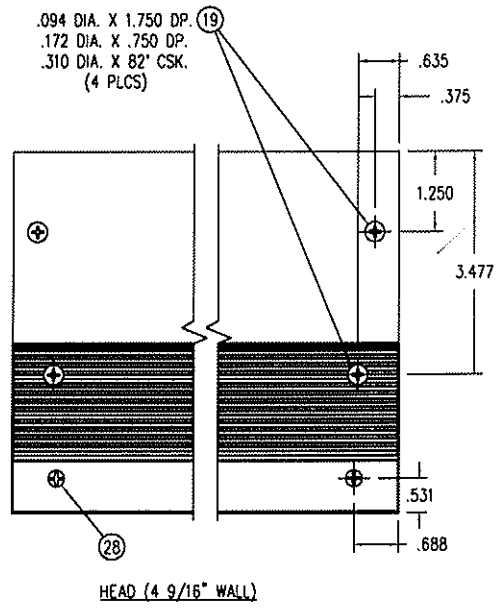

Architectural Testing

Test sample complies with these details.  
 Deviations are noted.

Report# 82573/S2743  
 Date 6-12-08 Tech 10

THIS DRAWING AND ITS CONTENTS ARE THE PROPERTY OF EAGLE WINDOW & DOOR. NO USE OR REPRODUCTION OF THE CONTENTS OF THIS DOCUMENT IS PERMITTED WITHOUT THE EXPRESS WRITTEN PERMISSION OF EAGLE WINDOW & DOOR.

TITLE: CAFDI - SINGLE DOOR UNIT ASSEMBLY

FINISH:

MATL:

DFT: 030648 SCALE: 1=3  
 DCN: 0710 DRWC: 056C  
 DATE: 3/25/2008 C 02

NO	DESCRIPTION	DFT	DOC	DATE
				DATE: 3/25/2008 C 02

NOTE: 1. INSERT CORNER KEYS BEFORE APPLYING SEALANT.

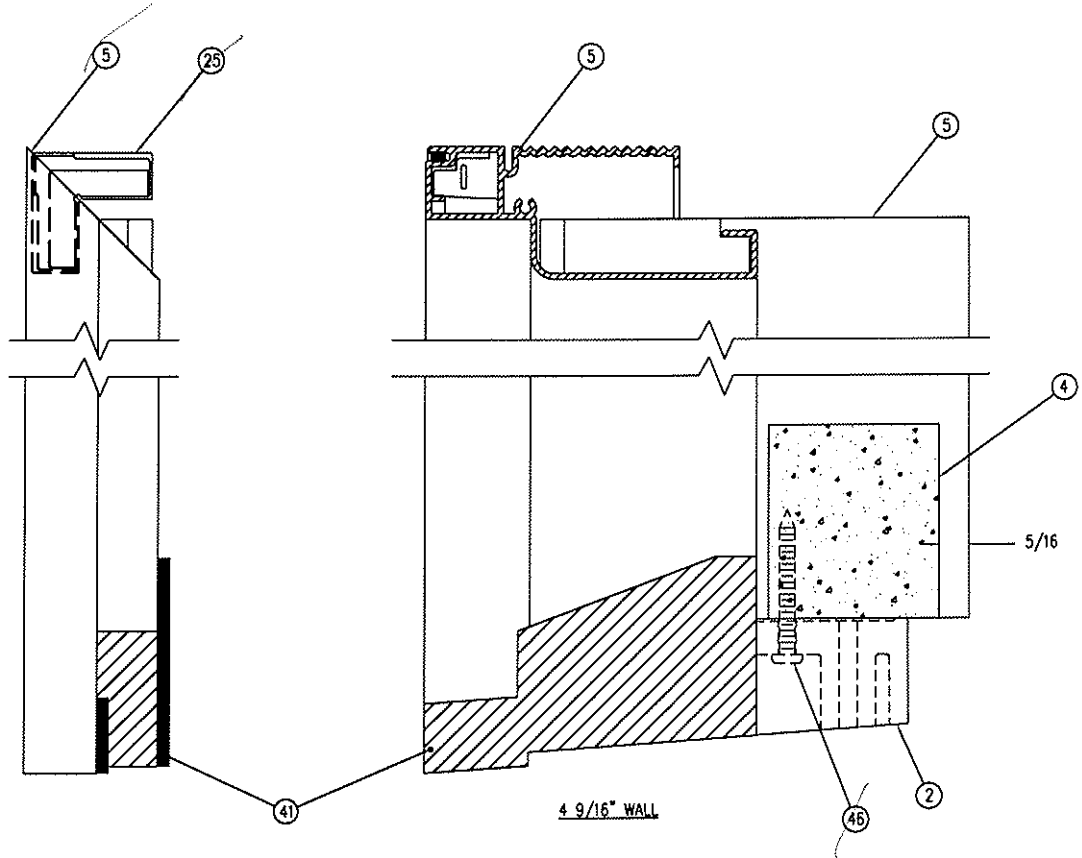

**Architectural Testing**  
 Test sample complies with these details.  
 Deviations are noted.  
 Report# 82573, 82743  
 Date 6/12/08 Tech TF

THIS DRAWING AND ITS CONTENTS ARE THE PROPERTY OF EAGLE WINDOW & DOOR. NO USE OR REPRODUCTION OF THE CONTENTS OF THIS DOCUMENT IS PERMITTED WITHOUT THE EXPRESS WRITTEN PERMISSION OF EAGLE WINDOW & DOOR.  
 TITLE: CAFD1 - SINGLE DOOR UNIT ASSEMBLY  
 FINISH:  
 MATL:  
 DFT: 030648 SCALE: 1=2  
 DCN: 0710 DRWG: 056C  
 DATE: 3/25/2008 C 03

NO	DESCRIPTION	DFT	DOC	DATE

NOTE: 1. SILICONE OR BUTYL TAPE SEALANT MUST RUN ENTIRE LENGTH OF SEAM BETWEEN STILE AND RAIL CLADDING.  
 2. ONE PANEL WEDGE IS INSERTED AT EACH END OF STILES (4 TOTAL).

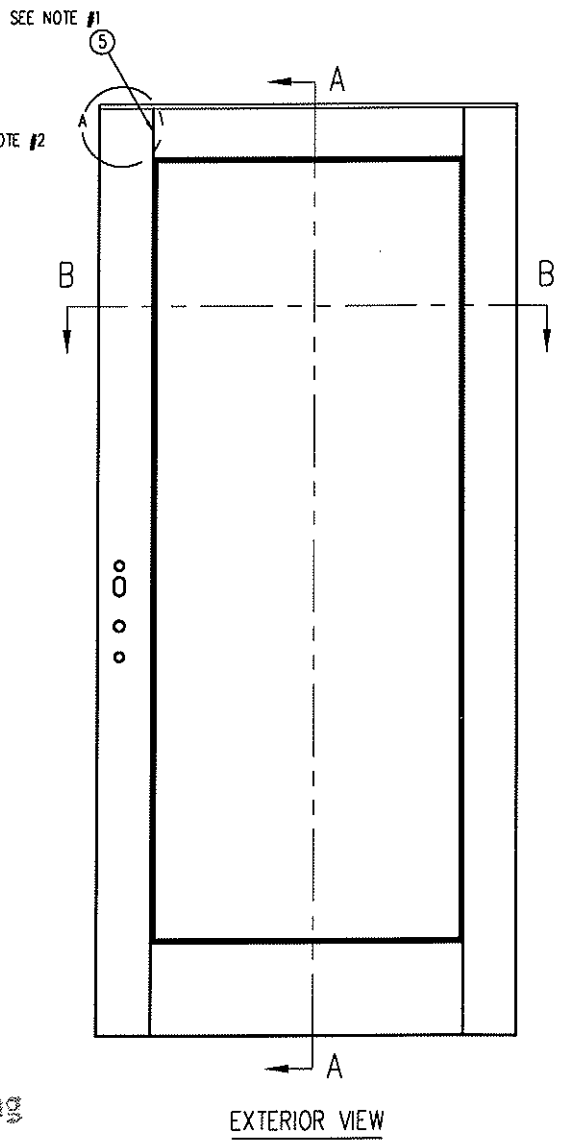
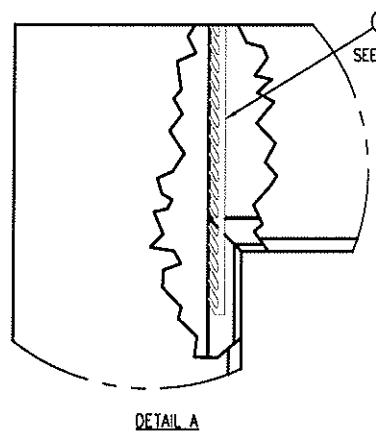
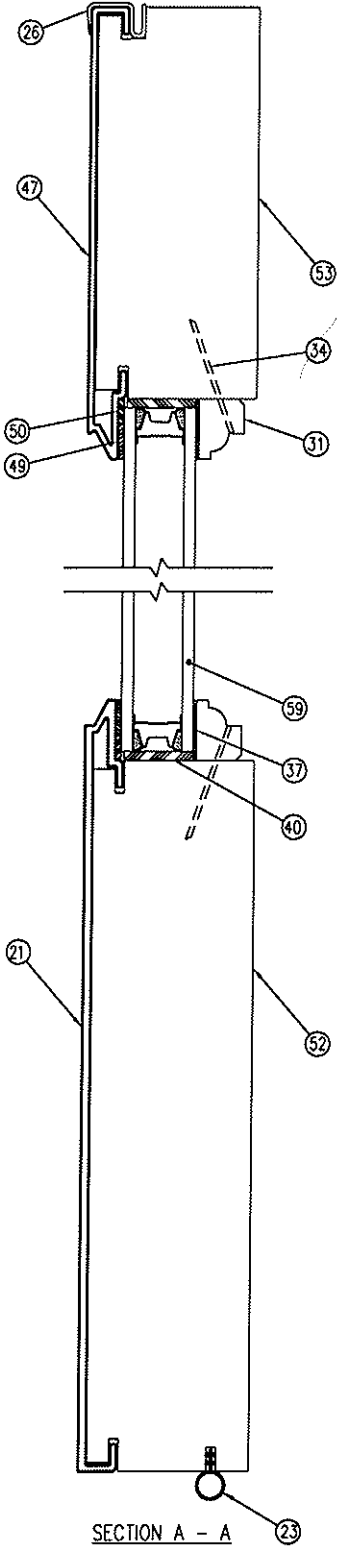
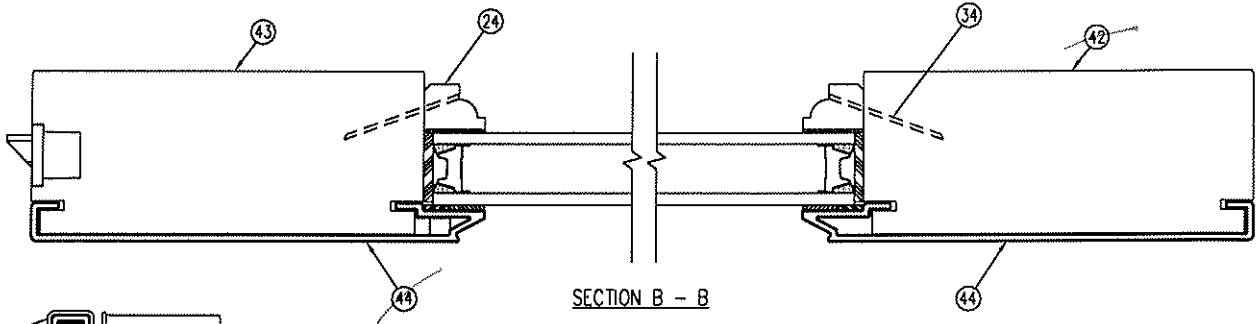

**Architectural Testing**

Test sample complies with these details.  
 Deviations are noted.

Report# 82575, 82743  
 Date 6/12/03 Tech JG

THIS DRAWING AND ITS CONTENTS ARE THE PROPERTY OF EAGLE WINDOW & DOOR. NO USE OR REPRODUCTION OF THE CONTENTS OF THIS DOCUMENT IS PERMITTED WITHOUT THE EXPRESS WRITTEN PERMISSION OF EAGLE WINDOW & DOOR.	
TITLE: CAFDI - SINGLE DOOR PANEL ASSEMBLY	
FINISH:	
MATERIAL:	
DFT: 030648	SCALE: 1=2
DCN: 0710	DRWG: 056C
DATE: 3/25/2008	C 04

NO	DESCRIPTION	QTY	DOC	DATE

NOTE: 1. INJECT 1.75 CC OF GLUE INTO EACH RAIL HOLE AND INSERT DOWEL UNTIL FULLY SEATED.  
 2. APPLY THIN COAT OF GLUE TO ENTIRE SURFACE OF STILE HOLE AND DOWEL PRIOR TO ASSEMBLING PANEL.

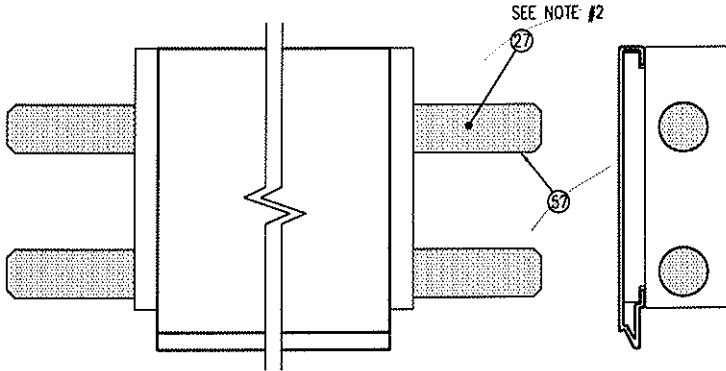
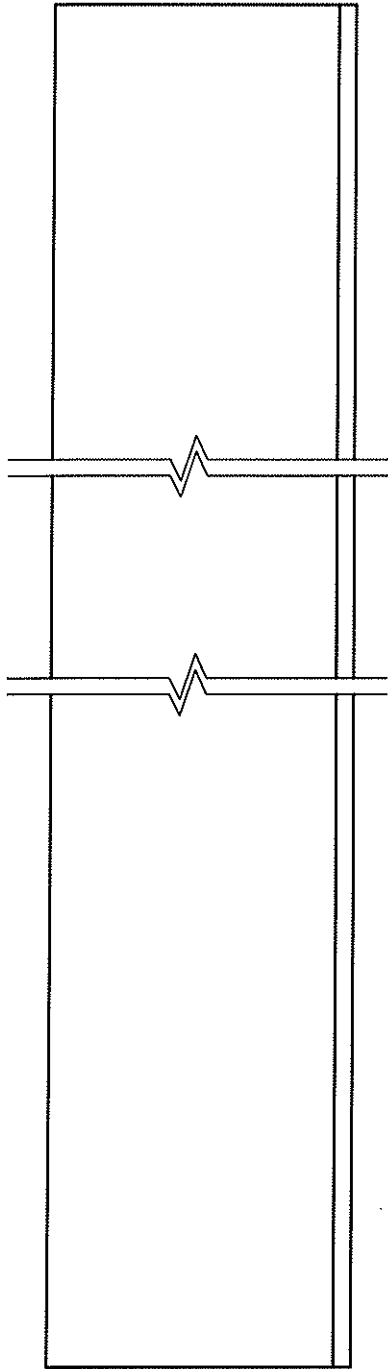
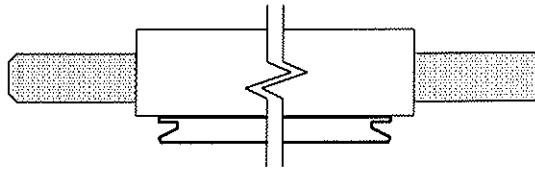
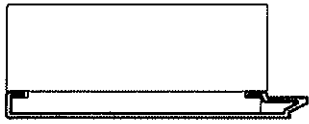

Architectural Testing

Test sample complier with these details.  
 Deviations are noted.

Report# 82573, 82743  
 Date 6-12-07 Tech T6

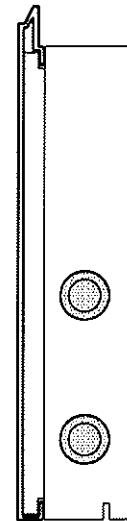
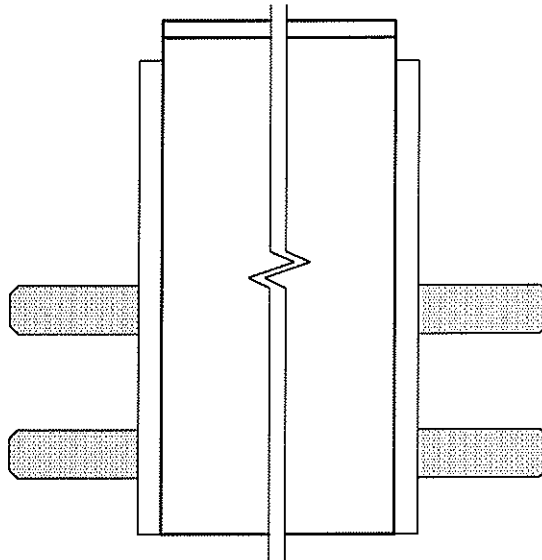

STILE

RAILS

THIS DRAWING AND ITS CONTENTS ARE THE PROPERTY OF EAGLE WINDOW & DOOR. NO USE OR REPRODUCTION OF THE CONTENTS OF THIS DOCUMENT IS PERMITTED WITHOUT THE EXPRESS WRITTEN PERMISSION OF EAGLE WINDOW & DOOR.	
TITLE: CAFDI - SINGLE DOOR PANEL ASSEMBLY	
FINISH:	
MATERIAL:	
DPT: 030648	SCALE: 1=3
DCN: 0710	DRWG:
DATE: 3/25/2008	C 05

NO	DESCRIPTION	DFT	DOC	DATE

NOTE: 1. A BEAD OF SILICONE SEALANT MUST BE APPLIED TO ENDS OF STILE CLADDING AND THE ENTIRE WIDTH OF PANEL BEFORE INSTALLING CAP.

SEE NOTE #1

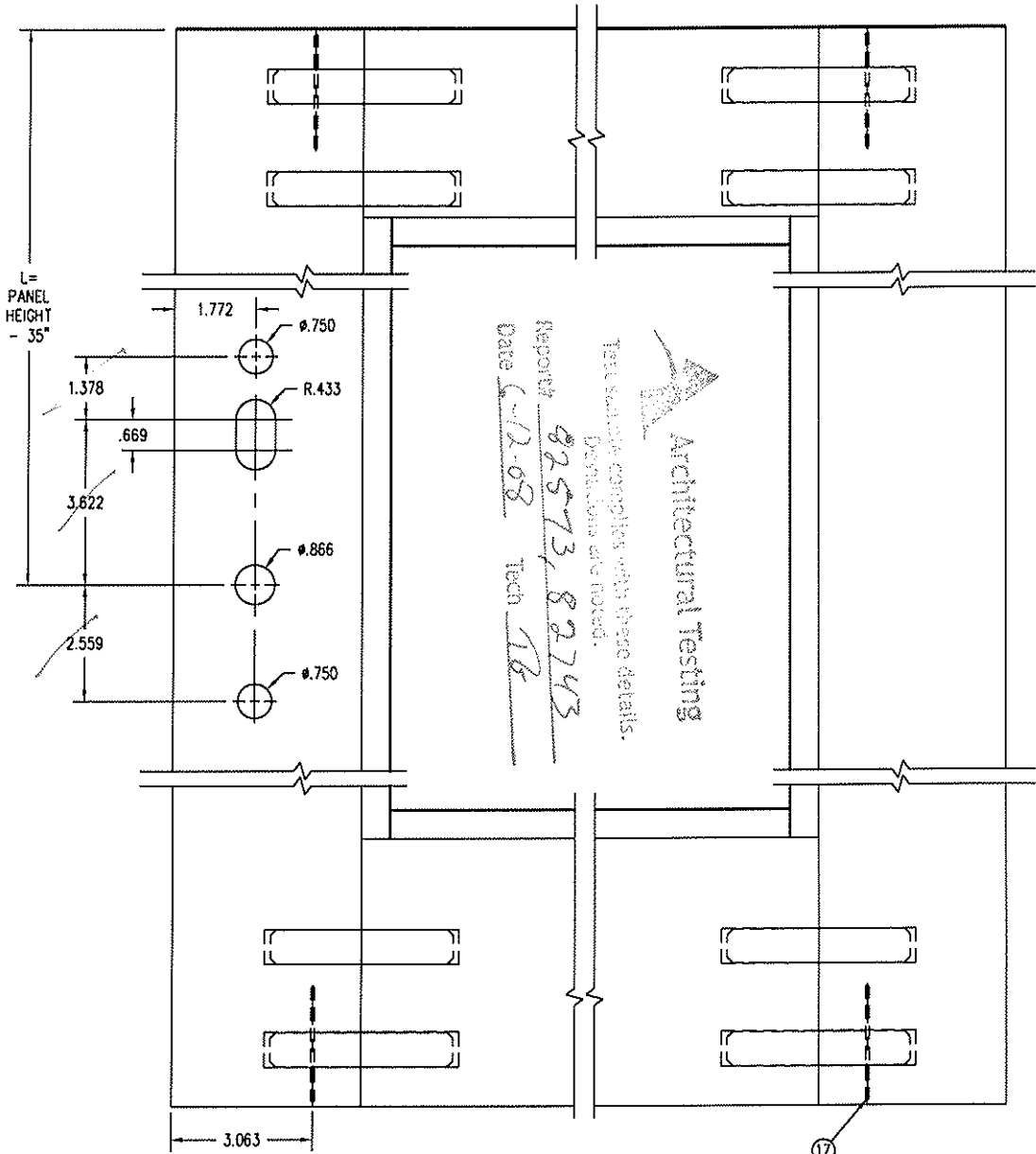
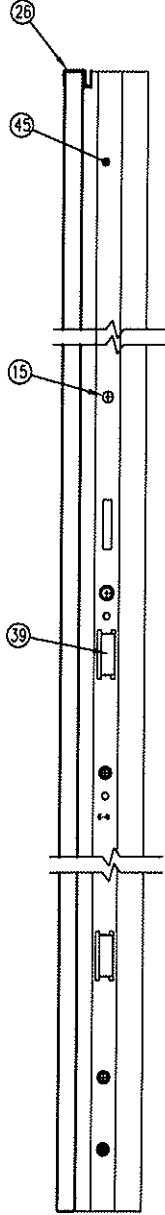

INTERIOR VIEW

FRAME	PANEL	L
80	77 3/16	42 3/16
82	79 3/16	44 3/16
84	81 3/16	46 3/16
96	93 3/16	58 3/16

THIS DRAWING AND ITS CONTENTS ARE THE PROPERTY OF EAGLE WINDOW & DOOR. NO USE OR REPRODUCTION OF THE CONTENTS OF THIS DOCUMENT IS PERMITTED WITHOUT THE EXPRESS WRITTEN PERMISSION OF EAGLE WINDOW & DOOR.

TITLE: CAFDI - SINGLE DOOR  
PANEL ASSEMBLY

FINISH:

MATL:

DFT: 030648 SCALE: 1=4  
DCN: 0710 DRWG:  
DATE: 3/25/2008 C 06

NO	DESCRIPTION	DFT	DOC	DATE

NO.	DWG. NO.	PART DESCRIPTION	QUANTITY	MATERIAL	SUPPLIER
1	221M	HEAD JAMB	1	WOOD	PAC. WOOD LAMINATES
2	A656	JAMB RISER BLOCK	2		LAKE COUNTRY SALES
3	A63W	4 9/16" WALL JAMB CLADDING	2	ALUMINUM	BONNELL
4	A58N	2" FOAM CORNER PAD	2		EN DURA
5	A030	SILICONE SEALANT	AS REQUIRED	SILICONE	DOW CORNING
6	A01A	SEALANT BUTYL TAPE	AS REQUIRED	BUTYL RUBBER	PTI INC.
7	A63P	CFDI 4 9/16" SILL CAP	1	ALUMINUM	BONNELL
8	A699	PANEL WEDGE	4	NYLON	LAKE COUNTRY SALES
9	A395	GU HANDLE ASSEMBLY	1		GU
10	A63W	4 9/16" WALL HEAD CLADDING	1	ALUMINUM	PRIES
11	221M	SIDE JAMB	1	WOOD	EAGLE WINDOW & DOOR
12	A05X	#10-24 THREADED INSERT	1		ABILITY FASTENERS
13	A62G	FRAME WEATHERSTRIP	2		SCHLEGEL
14	A39A	#10-24 x 5/8" FH. MS. (HINGE TO THREADED INSERT)	AS REQUIRED		ABILITY FASTENERS
15	A659	4 9/16" SILL BASE	1	ALUMINUM	BONNELL
16	A39W	#7 x 1 1/4" FHMS S.S.	AS REQUIRED		ABILITY FASTENERS
17	A517	TOP & BOTTOM LATCH STRIKE	2		FPL
18	A43D	2 1/2" BRAD .077 DIA.	4	GALVANIZED STEEL	CARLSON
19	A28T	#8 x 2 1/2" FHMS	4	STEEL	ABILITY FASTENERS
20	A02E	#8 x 1 3/4" FHWS Z & Y	AS REQUIRED	STEEL	SILLCVRSR
21	A518	CENTER STRIKE PLATE (LATCH & DEADBOLT)	1		FPL
22	A64K	8" BOTTOM RAIL CLADDING	1	ALUMINUM	PRIES
23	A47A	DUST CUP FOR T & B LATCH STRIKE	2		LAKE COUNTRY SALES
24	A661	LOWER PANEL WEATHERSTRIP	1		SCHLEGEL
25	220J	VERTICAL COLONIAL GLAZING STOP	2	WOOD	EAGLE WINDOW & DOOR
26	A100	NYLON CORNER KEY	2		LAKE COUNTRY SALES
27	A49X	PANEL CAP	1	ALUMINUM	BONNELL
28	A01D	WOOD ADHESIVE	AS REQUIRED	COPOLYMER	NATIONAL CASEIN
29	A11K	#8 x 7/16" #6 HEAD FHMS S.S.	4		ABILITY FASTENERS
30	A59Y	SILL WEATHERSTRIP	1		AMESBURY FOAMTITE
31	A62G	FRAME WEATHERSTRIP	1		SCHLEGEL
32	220N	HORIZONTAL COLONIAL GLAZING STOP	2	WOOD	EAGLE WINDOW & DOOR
33	A515	#12 x 2 1/2" FHWS S.S.	AS REQUIRED		ABILITY FASTENERS
34	A516	#12 X 1 1/2 FH. WS. (FPL)	AS REQUIRED		ABILITY FASTENERS
35	A40F	1 1/4" 18GA HARD STL BRAD	AS REQUIRED	STEEL	PACKAGING INC.
36	2225	OAK SILL TRIM	1		EAGLE WINDOW & DOOR
37	A52X	4 9/16" SILL FOAM TAPE	2		CLIM-A-TECH
38	A264	ADHESIVE TAPE	2	POLYETHYLENE	ADHESIVE RESEARCH
39	A49P	COMMERCIAL HINGE	AS REQUIRED		FPL
40	A38E	GU CENTER GEAR	1		GU
41	A00E	GLASS SETTING BLOCK, NEOPRENE	AS REQUIRED	NEOPRENE RUBBER	CLIM-A-TECH
42	A622	4 9/16" SILL JAMB FOAM PAD	2		CLIM-A-TECH
43	20D6	4 11/16" HINGE STILE	2	WOOD	PAC. WOOD LAMINATES
44	20DB	4 11/16" LOCK STILE	2	WOOD	PAC. WOOD LAMINATES
45	A613	4 11/16" STILE CLADDING	2	ALUMINUM	PRIES
46	A38M	G-U TOP EXTENSION	AS REQUIRED		GU
47	A67F	#8 X 1 1/2" PHMS S.S.	1		ABILITY FASTENERS
48	A613	4 11/16" TOP RAIL CLADDING	1	ALUMINUM	PRIES
49	A47K	HINGE CUP	AS REQUIRED		LAKE COUNTRY SALES
50	A01A	SEALANT BUTYL TAPE	AS REQUIRED	BUTYL RUBBER	PTI INC.
51	A08K	GLAZING SHIM	AS REQUIRED	NEOPRENE RUBBER	CLIM-A-TECH
52	A47J	HINGE SHIM	AS REQUIRED		LAKE COUNTRY SALES
53	20DJ	8" BOTTOM RAIL	1	WOOD	PAC. WOOD LAMINATES
54	20D6	4 11/16" TOP RAIL	1	WOOD	PAC. WOOD LAMINATES
55	A243	#6 X 1" FH. ES.	AS REQUIRED		ABILITY FASTENERS
56	A00R	#7 X 5/8" FHMS S.S.	AS REQUIRED		ABILITY FASTENERS
57	A00T	#7 X 7/8" FHWS S.S.	AS REQUIRED		DECO PRODUCTS CO.
58	20A4	WOOD DOWEL	AS REQUIRED	WHITE BIRCH	EXCEL DOWEL
59	A469	CENTER STRIKE DUST CUP	1		LAKE COUNTRY SALES
60	A019	3/4" INSULATED GLASS	1	GLASS	CARDINAL IG
61	H-40	5/8" BETWEEN GLASS MUNTIN	AS REQUIRED	ALUMINUM	ALLMETAL
62	P/PPD	1" CONTOUR MUNTIN	AS REQUIRED	ALUMINUM	ALLMETAL
63	220H	1 1/2" INTERIOR COLONIAL MDL BAR	AS REQUIRED	WOOD	EAGLE WINDOW & DOOR
64	H-40	SPACER CHANNEL	AS REQUIRED	ALUMINUM	ALLMETAL
65	A507	1 1/2" EXTERIOR MDL BAR	AS REQUIRED	ALUMINUM	BONNELL
66	A67X	1 1/2" MDL ADHESIVE TAPE (EXTERIOR TAPE)	AS REQUIRED	POLYETHYLENE	ADHESIVE RESEARCH
67	A67L	1 1/2" MDL ADHESIVE TAPE (INTERIOR TAPE)	AS REQUIRED	POLYETHYLENE	ADHESIVE RESEARCH
68	220H	1 1/2" INTERIOR COLONIAL MDL BAR	AS REQUIRED	WOOD	EAGLE WINDOW & DOOR
69	H-40	SPACER CHANNEL	AS REQUIRED	ALUMINUM	ALLMETAL
70	A507	1 1/8" EXTERIOR MDL BAR	AS REQUIRED	ALUMINUM	BONNELL
71	A67W	1 1/8" MDL ADHESIVE TAPE (EXTERIOR TAPE)	AS REQUIRED	POLYETHYLENE	ADHESIVE RESEARCH
72	A67R	1 1/8" MDL ADHESIVE TAPE (INTERIOR TAPE)	AS REQUIRED	POLYETHYLENE	ADHESIVE RESEARCH
73	220H	7/8" INTERIOR COLONIAL MDL BAR	AS REQUIRED	WOOD	EAGLE WINDOW & DOOR
74	H-40	SPACER CHANNEL	AS REQUIRED	ALUMINUM	ALLMETAL
75	A507	7/8" EXTERIOR MDL BAR	AS REQUIRED	ALUMINUM	BONNELL
76	A67T	7/8" MDL ADHESIVE TAPE (EXTERIOR TAPE)	AS REQUIRED	POLYETHYLENE	ADHESIVE RESEARCH
77	A67N	7/8" MDL ADHESIVE TAPE (INTERIOR TAPE)	AS REQUIRED	POLYETHYLENE	ADHESIVE RESEARCH
78	20FA	5/8" INTERIOR COLONIAL MDL BAR	AS REQUIRED	WOOD	EAGLE WINDOW & DOOR
79	H-40	SPACER CHANNEL	AS REQUIRED	ALUMINUM	ALLMETAL
80	A72D	5/8" EXTERIOR MDL BAR	AS REQUIRED	ALUMINUM	COLONIAL CRAFT
81	A75M	5/8" MDL ADHESIVE TAPE (EXTERIOR TAPE)	AS REQUIRED	POLYETHYLENE	ADHESIVE RESEARCH
82	A75M	5/8" MDL ADHESIVE TAPE (INTERIOR TAPE)	AS REQUIRED	POLYETHYLENE	ADHESIVE RESEARCH
82	N/A	ADHESIVE TAPE	AS REQUIRED	POLYETHYLENE	CARDINAL IG



## Architectural Testing

Test sample completed with these details.  
Dimensions are correct.

Report# 82754, 82575, 82743

Date 7-11-08 Tech m G

TITLE: CAFDI - SINGLE UNIT ASSEMBLY

FINISH:

MATL:

DFT: KJS SCALE: 1=1

DCN: 0710 DRWG: 056G

NO | DESCRIPTION | DFT | DOC | DATE | DATE: 3/25/08 C 09

NO.	DWG. NO.	PART DESCRIPTION	QUANTITY	MATERIAL	SUPPLIER
47	A613	4 11/16" TOP RAIL CLADDING	1	ALUMINUM	PRIES
48	A47K	HINGE CUP	AS REQUIRED		LAKE COUNTRY SALES
49	A01A	SEALANT BUTYL TAPE	AS REQUIRED	BUTYL RUBBER	PTI INC.
50	A08K	GLAZING SHIM	AS REQUIRED	NEOPRENE RUBBER	CLIM-A-TECH
51	A47J	HINGE SHIM	AS REQUIRED		LAKE COUNTRY SALES
52	20DJ	8" BOTTOM RAIL	1	WOOD	PAC. WOOD LAMINATES
53	20D6	4 11/16" TOP RAIL	1	WOOD	PAC. WOOD LAMINATES
54	A243	#6 X 1" FH. ES.			ABILITY FASTENERS
55	A00R	#7 X 5/8" FHMS S.S.	AS REQUIRED		ABILITY FASTENERS
56	A00T	#7 X 7/8" FHWS S.S.	AS REQUIRED		DECO PRODUCTS CO.
57	20A4	WOOD DOWEL	AS REQUIRED	WHITE BIRCH	EXCEL DOWEL
58	A47B	ASTRAGAL DUST CUP	1		LAKE COUNTRY SALES
59	A38M	G-U TOP EXTENSION	AS REQUIRED		GU
60	A38E	GU CENTER GEAR	1		GU
61	A49P	COMMERCIAL HINGE	AS REQUIRED		FPL
62	A47A	DUST CUP FOR T & B LATCH STRIKE	2		LAKE COUNTRY SALES
63	A518	CENTER STRIKE PLATE (LATCH & DEADBOLT)	1		FPL
64	A517	TOP & BOTTOM LATCH STRIKE	2		FPL
65	2070	ASTRAGAL	1	WOOD	EAGLE WINDOW & DOOR
66	A03G	MORTISE DOOR BOLT	1		GU
67	A03H	TOP & BOTTOM SHOOT BOLT	2		GU
68	A04T	#8 x 1/2" PPH TEKS #2 SCREW			ABILITY FASTENERS
69	A04Y	ASTRAGAL FLAT PLATE	1		LAKE COUNTRY SALES
70	A019	3/4" INSULATED GLASS	1	GLASS	CARDINAL IG
71	H-40	5/8" BETWEEN GLASS MUNTIN	AS REQUIRED	ALUMINUM	ALLMETAL
72	P/PD	1" CONTOUR MUNTIN	AS REQUIRED	ALUMINUM	ALLMETAL
73	220H	1 1/2" INTERIOR COLONIAL MDL BAR	AS REQUIRED	WOOD	EAGLE WINDOW & DOOR
74	H-40	SPACER CHANNEL	AS REQUIRED	ALUMINUM	ALLMETAL
75	A507	1 1/2" EXTERIOR MDL BAR	AS REQUIRED	ALUMINUM	BONNELL
76	A67X	1 1/2" MDL ADHESIVE TAPE (EXTERIOR TAPE)	AS REQUIRED	POLYETHYLENE	ADHESIVE RESEARCH
77	A67L	1 1/2" MDL ADHESIVE TAPE (INTERIOR TAPE)	AS REQUIRED	POLYETHYLENE	ADHESIVE RESEARCH
78	220H	1 1/8" INTERIOR COLONIAL MDL BAR	AS REQUIRED	WOOD	EAGLE WINDOW & DOOR
79	H-40	SPACER CHANNEL	AS REQUIRED	ALUMINUM	ALLMETAL
80	A507	1 1/8" EXTERIOR MDL BAR	AS REQUIRED	ALUMINUM	BONNELL
81	A67W	1 1/8" MDL ADHESIVE TAPE (EXTERIOR TAPE)	AS REQUIRED	POLYETHYLENE	ADHESIVE RESEARCH
82	A67R	1 1/8" MDL ADHESIVE TAPE (INTERIOR TAPE)	AS REQUIRED	POLYETHYLENE	ADHESIVE RESEARCH
83	220H	7/8" INTERIOR COLONIAL MDL BAR	AS REQUIRED	WOOD	EAGLE WINDOW & DOOR
84	H-40	SPACER CHANNEL	AS REQUIRED	ALUMINUM	ALLMETAL
85	A507	7/8" EXTERIOR MDL BAR	AS REQUIRED	ALUMINUM	BONNELL
86	A67T	7/8" MDL ADHESIVE TAPE (EXTERIOR TAPE)	AS REQUIRED	POLYETHYLENE	ADHESIVE RESEARCH
87	A67N	7/8" MDL ADHESIVE TAPE (INTERIOR TAPE)	AS REQUIRED	POLYETHYLENE	ADHESIVE RESEARCH
88	20FA	5/8" INTERIOR COLONIAL MDL BAR	AS REQUIRED	WOOD	EAGLE WINDOW & DOOR
89	H-40	SPACER CHANNEL	AS REQUIRED	ALUMINUM	ALLMETAL
90	A72D	5/8" EXTERIOR MDL BAR	AS REQUIRED	ALUMINUM	COLONIAL CRAFT
91	A75N	5/8" MDL ADHESIVE TAPE (EXTERIOR TAPE)	AS REQUIRED	POLYETHYLENE	ADHESIVE RESEARCH
92	A75M	5/8" MDL ADHESIVE TAPE (INTERIOR TAPE)	AS REQUIRED	POLYETHYLENE	ADHESIVE RESEARCH
93	N/A	ADHESIVE TAPE	AS REQUIRED	POLYETHYLENE	CARDINAL IG



Test sample complies with these details.  
Deviations are noted.

Report# 82754, 82575, 82743

Date 7-11-08 Tech MB

TITLE: CAFDI - DOUBLE UNIT ASSEMBLY	
FINISH:	
MATL:	
DFT: KJS	SCALE: 1=1
DCN: 0710	DRWG: 056H
DATE: 3/25/08	C 12

NO	DESCRIPTION	DFT	DOC	DATE
----	-------------	-----	-----	------

- NOTE: 1. UNLESS OTHERWISE SPECIFIED, ALL DIMENSIONS SHOWN ARE IN INCHES AND ALL TOLERANCES ARE TO BE: DEC.  $\pm 0.005$ ; FRAC.  $\pm 1/64$ ; ANGLES  $\pm 1/2^\circ$ .  
 2. THIS VENEER TO HAVE MINIMUM THICKNESS OF .080.

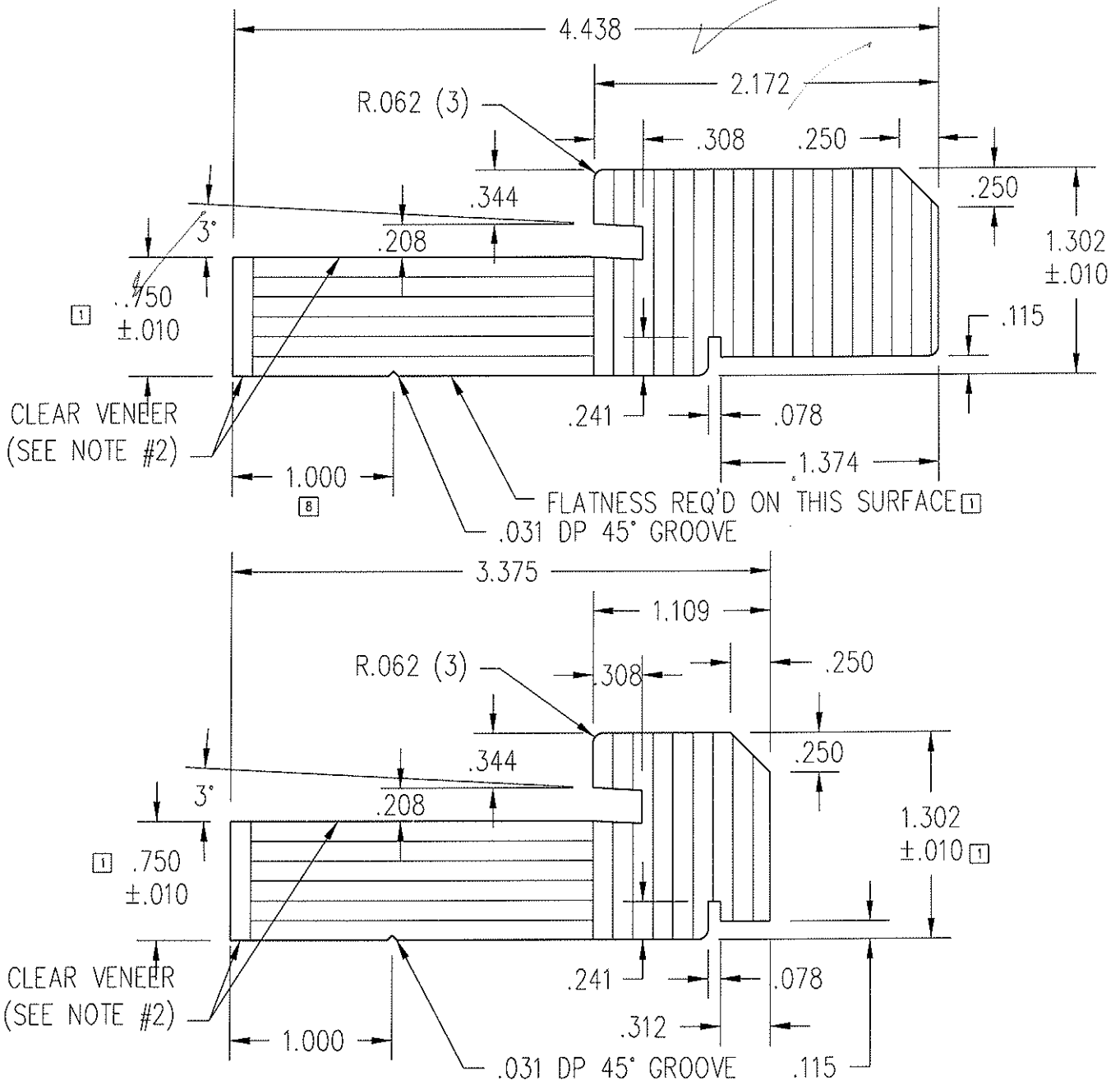

RIPPED DOWN FOR 3 1/2" WALL



Architectural Testing

Test sample complies with these details.  
 Dimensions are noted.

Report# 825731, 82743  
 Date 6-12-08 Tech 16

THIS DRAWING AND ITS CONTENTS ARE THE PROPERTY OF EAGLE WINDOW & DOOR. NO USE OR REPRODUCTION OF THE CONTENTS OF THIS DOCUMENT IS PERMITTED WITHOUT THE EXPRESS WRITTEN PERMISSION OF EAGLE WINDOW & DOOR.

TITLE: CLAD INSWING DOOR  
 WOOD JAMB

FINISH:

MATL: LVL

DFT: AWW SCALE: 1=1

DCN: 0794 DRWG: 221M

DATE: 10/31/2002 A 01 OF 05

01	ADDED SPECIFIC TOLERANCES	AWW		1/20/06
NO	DESCRIPTION	DFT	DOC	DATE

- NOTE: 1. UNLESS OTHERWISE SPECIFIED, ALL DIMENSIONS SHOWN ARE IN INCHES AND ALL TOLERANCES ARE TO BE: DEC.  $\pm 0.005$ ; FRAC.  $\pm 1/64$ ; ANGLES  $\pm 1/2^\circ$ .  
 2. UNLESS OTHERWISE SPECIFIED, WALL THICKNESS IS .058.  
 3. BREAK ALL CORNERS .015 UNLESS NOTED.  
 4. AREA = .569 SQ. IN.  
 5. MILL PART NO. = # M7339

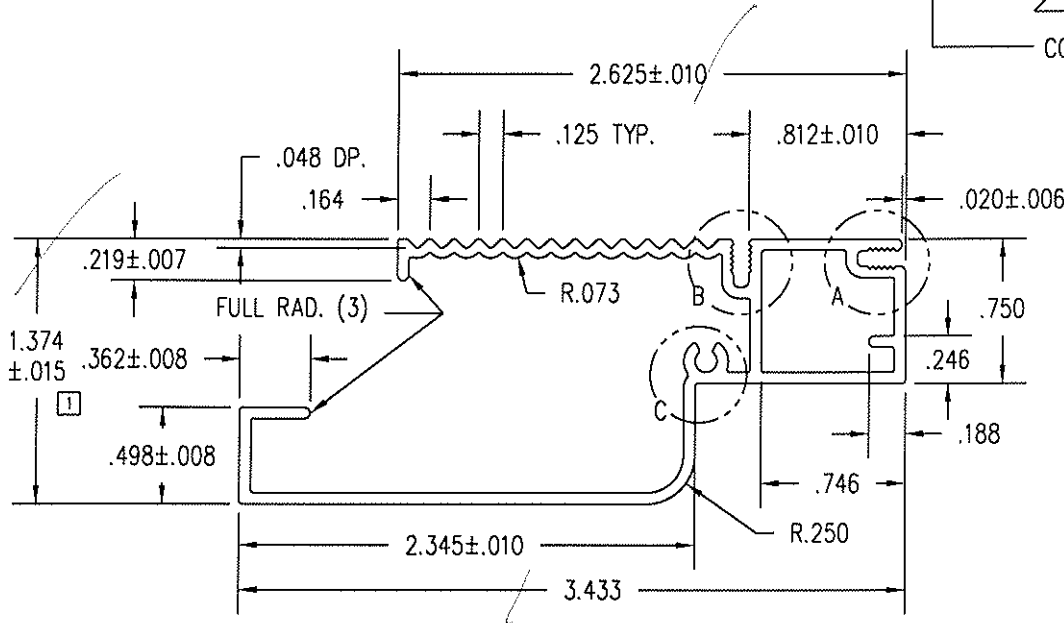
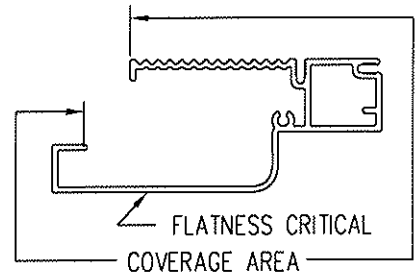

Report: 82573, 82743  
 Date: 6-12-02 Tech: AB  
 Tests done on shop with these details. Be cautious and noted.  
 Architectural Testing

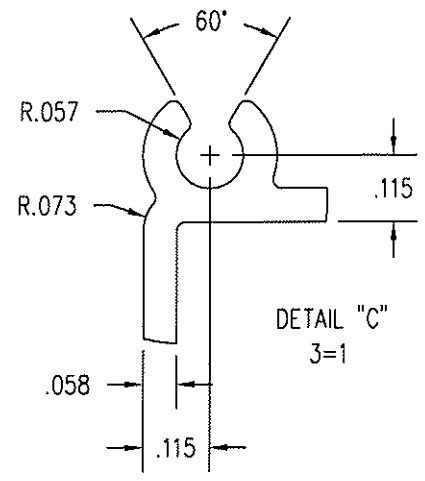
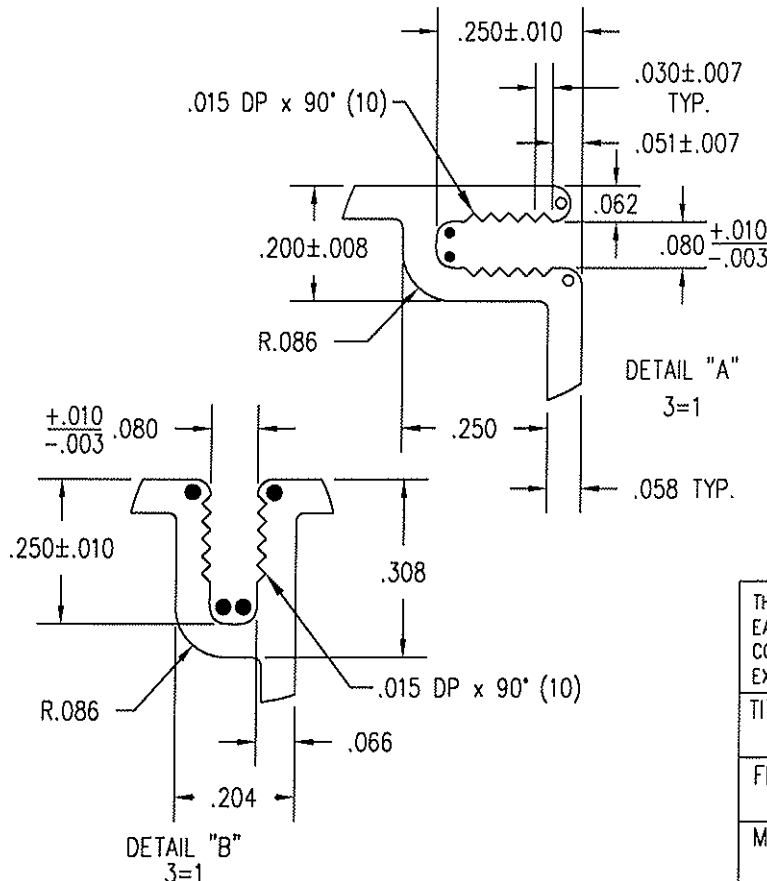

- R .028 (6)
- R .031 (2)

THIS DRAWING AND ITS CONTENTS ARE THE PROPERTY OF EAGLE WINDOW & DOOR. NO USE OR REPRODUCTION OF THE CONTENTS OF THIS DOCUMENT IS PERMITTED WITHOUT THE EXPRESS WRITTEN PERMISSION OF EAGLE WINDOW & DOOR.

TITLE:	CLAD INSWING DOOR 4 9/16" WALL METAL	
FINISH:	EAGLE'S STD. COLORS	
MATL:	6063 T-6 ALUMINUM	
DFT:	AWW	SCALE: 1=1
DCN:	0794	DRWG: A63W
DATE:	3/2/2004	A 01 OF 05

NO	DESCRIPTION	DFT	DOC	DATE
----	-------------	-----	-----	------

- NOTE: 1. UNLESS OTHERWISE SPECIFIED, ALL DIMENSIONS SHOWN ARE IN INCHES AND ALL TOLERANCES ARE TO BE: DEC.  $\pm 0.005$ ; FRAC.  $\pm 1/64$ ; ANGLES  $\pm 1/2^\circ$ .  
 2. TYPICAL WALL = .062, UNLESS NOTED.  
 3. BREAK ALL CORNERS .015 UNLESS NOTED.  
 4. AREA = .499 SQ. IN.  
 5. DARK BRONZE ANODIZED PART # 7425, MILL PART # M7336.

Architectural Testing  
 Eagle Window & Door  
 82573, 82743  
 Date 6-12-08 Tech 16

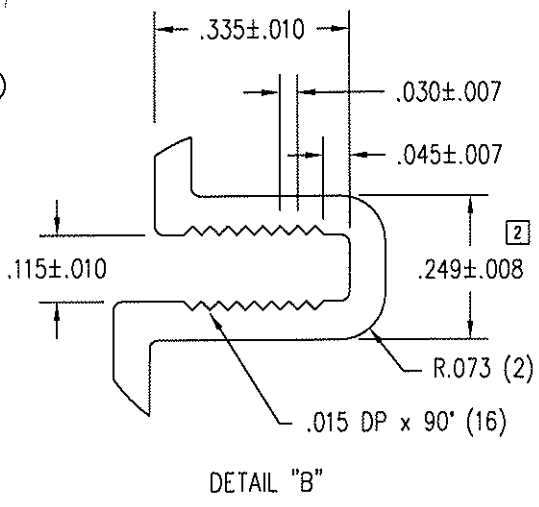
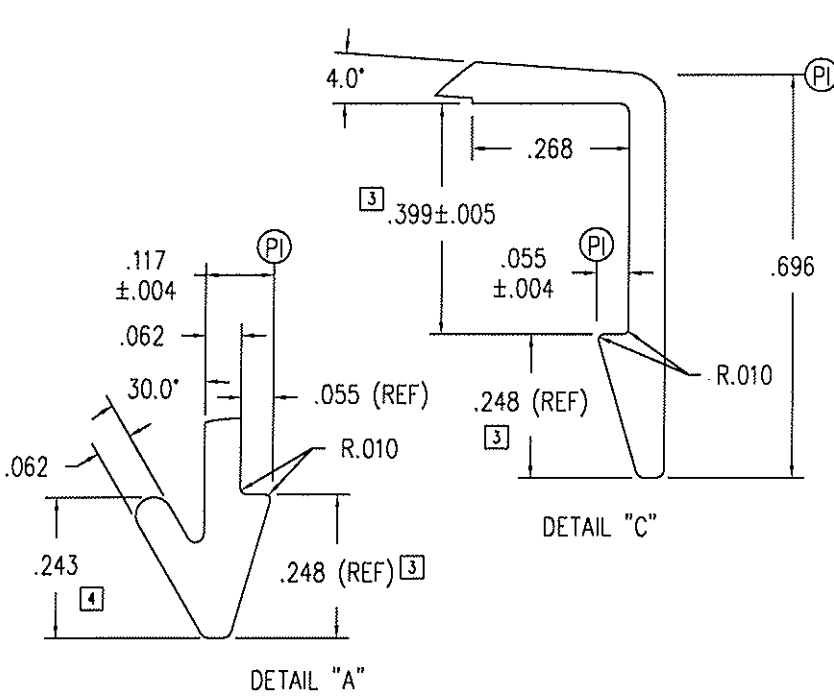
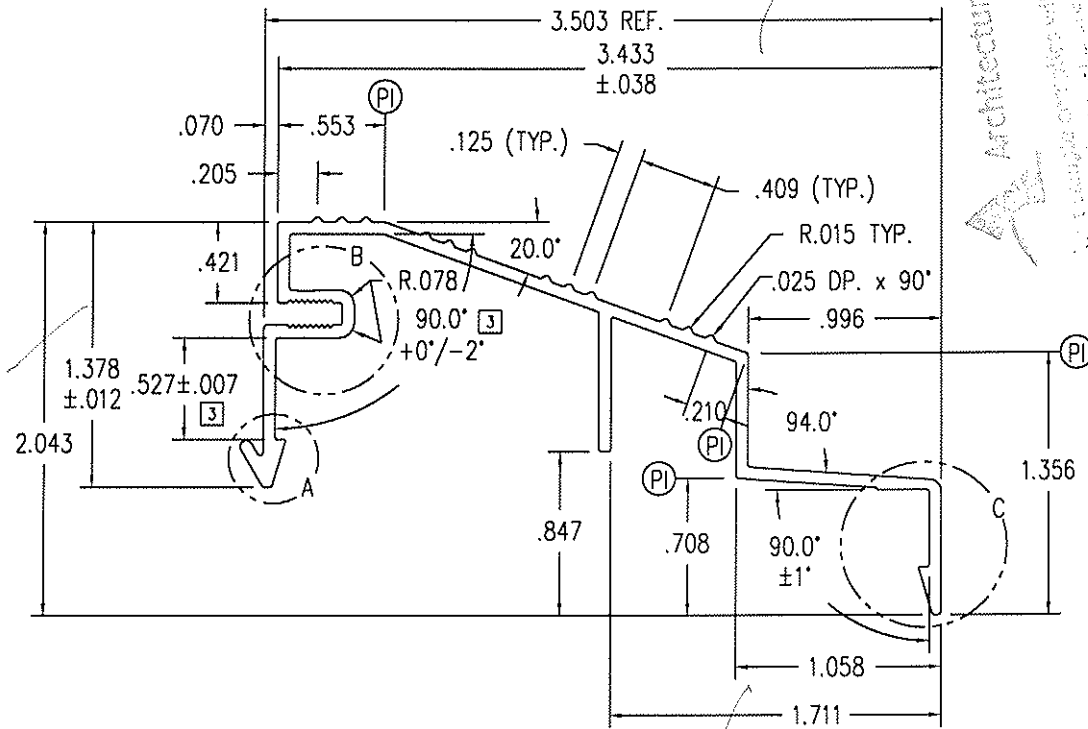

THIS DRAWING AND ITS CONTENTS ARE THE PROPERTY OF EAGLE WINDOW & DOOR. NO USE OR REPRODUCTION OF THE CONTENTS OF THIS DOCUMENT IS PERMITTED WITHOUT THE EXPRESS WRITTEN PERMISSION OF EAGLE WINDOW & DOOR.

TITLE:	INSWING HINGED DOOR 4 9/16" SILL CAP	
FINISH:	DARK BRONZE ANODIZED	
MATL:	6063 T-6 ALUMINUM	
DFT:	AWW	SCALE: 1=1
DCN:	0794	DRWG: A63P
DATE:	1/21/2003	A 01 OF 04

NO	DESCRIPTION	DFT	DOC	DATE
----	-------------	-----	-----	------

NOTE: 1. UNLESS OTHERWISE SPECIFIED, ALL DIMENSIONS SHOWN ARE IN INCHES AND ALL TOLERANCES ARE TO BE: DEC.  $\pm 0.005$ ; FRAC.  $\pm 1/64$ ; ANGLES  $\pm 1/2^\circ$ .

o = .031 RADIUS

2. TYPICAL WALL = .090, UNLESS NOTED.

3. BREAK ALL CORNERS .015 UNLESS NOTED.

4. POLYURETHANE THERMAL CONDUCTIVITY VIA ASTM C-518 IS .0913 BTU/HR-FT-DEGREE.

5. TOTAL AREA (NOT INCLUDING BREAK) = 1.357 SQ. IN.

6. CLEAR ANODIZED PART NO. = # 70531, DARK BRONZE ANODIZED PART NO. = # 604595. 2

7. FLATNESS OF  $\pm .004$  PER INCH OF PROFILE WIDTH REQUIRED.

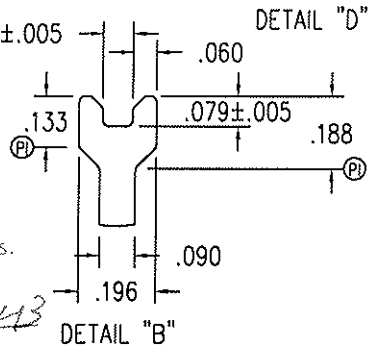
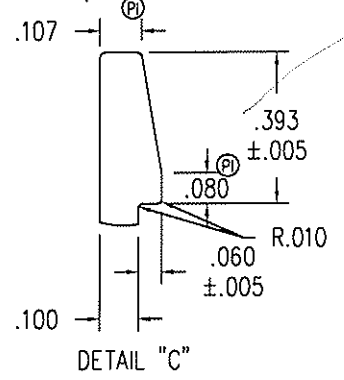
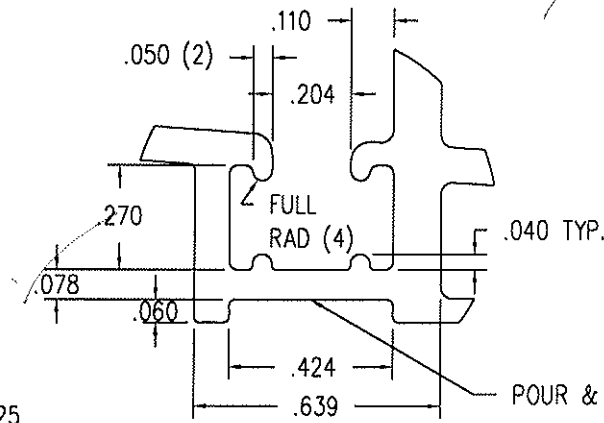
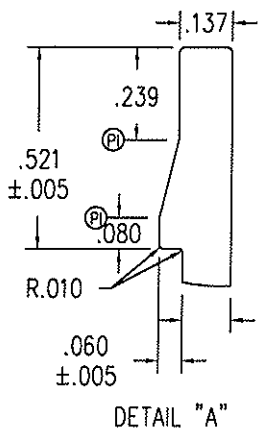
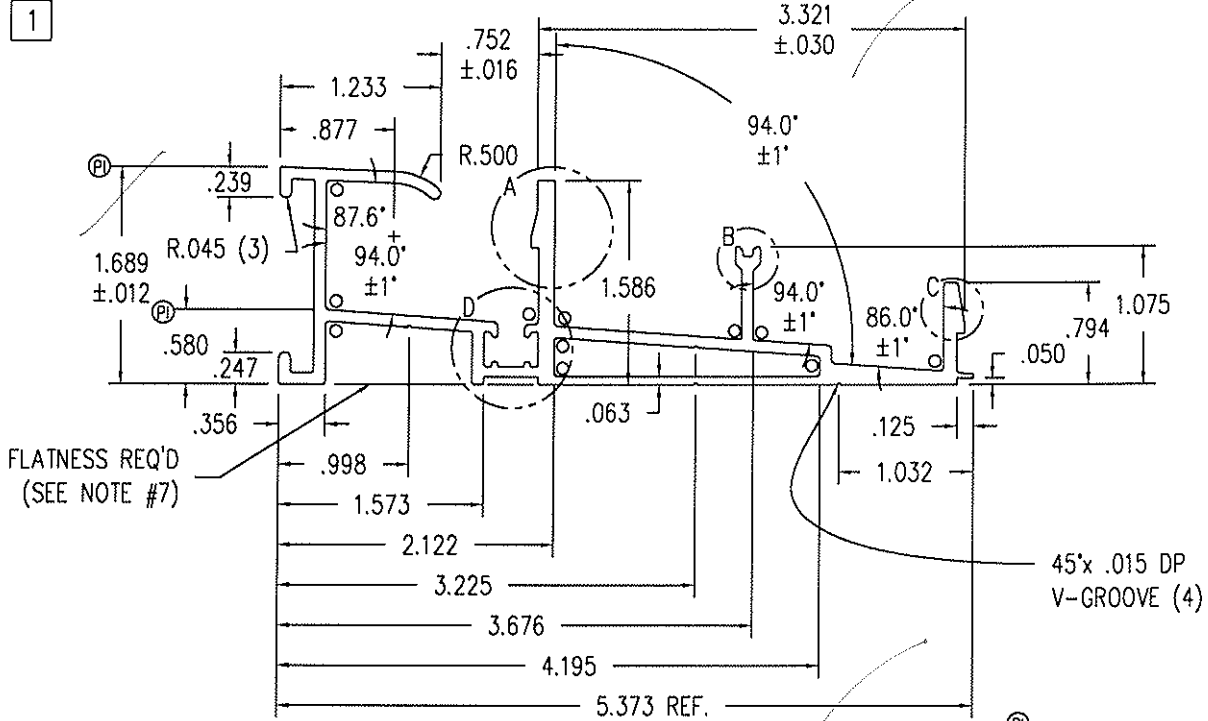

THIS DRAWING AND ITS CONTENTS ARE THE PROPERTY OF EAGLE WINDOW & DOOR. NO USE OR REPRODUCTION OF THE CONTENTS OF THIS DOCUMENT IS PERMITTED WITHOUT THE EXPRESS WRITTEN PERMISSION OF EAGLE WINDOW & DOOR.	
TITLE:	I/S HINGED DOOR 4 9/16" SILL BASE THERMALLY BROKEN
FINISH:	CLEAR ANODIZED
MATL:	6063 T-6 ALUMINUM
DFT:	TWN
SCALE:	1=1 1/2
DCN:	0794
DRWG:	A659
DATE:	6/16/2004
A	01 OF 03

Architectural Testing

Test sample complies with these details.  
 Deviations are noted.

Report# 82573, 82743  
 Date 6/12/08 Tech AB

NO	DESCRIPTION	DFT	DOC	DATE
02	ADDED DARK BRONZE ANODIZED PART #	TWN	1054	11/1/06
01	ADDED NOTE #7	KJS	1013	3/15/06

- NOTE: 1. UNLESS OTHERWISE SPECIFIED, ALL DIMENSIONS SHOWN ARE IN INCHES AND ALL TOLERANCES ARE TO BE: DEC.  $\pm 0.005$ ; FRAC.  $\pm 1/64$ ; ANGLES  $\pm 1/2^\circ$ .  
 2. WALL THICKNESS TO BE  $.062$  UNLESS OTHERWISE SPECIFIED.  
 3. ALL CORNERS TO BE  $.015$  UNLESS OTHERWISE SPECIFIED.  
 4. AREA =  $.743$  SQ. IN.

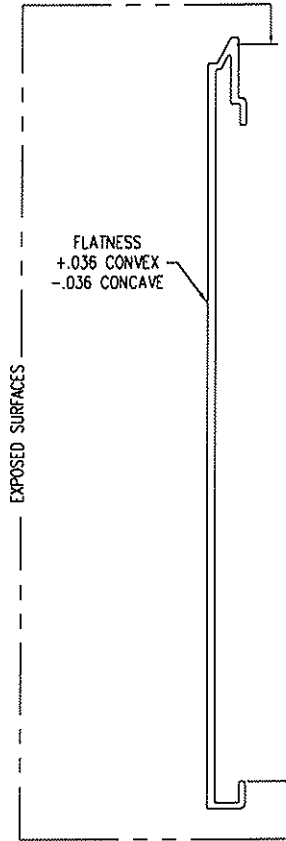
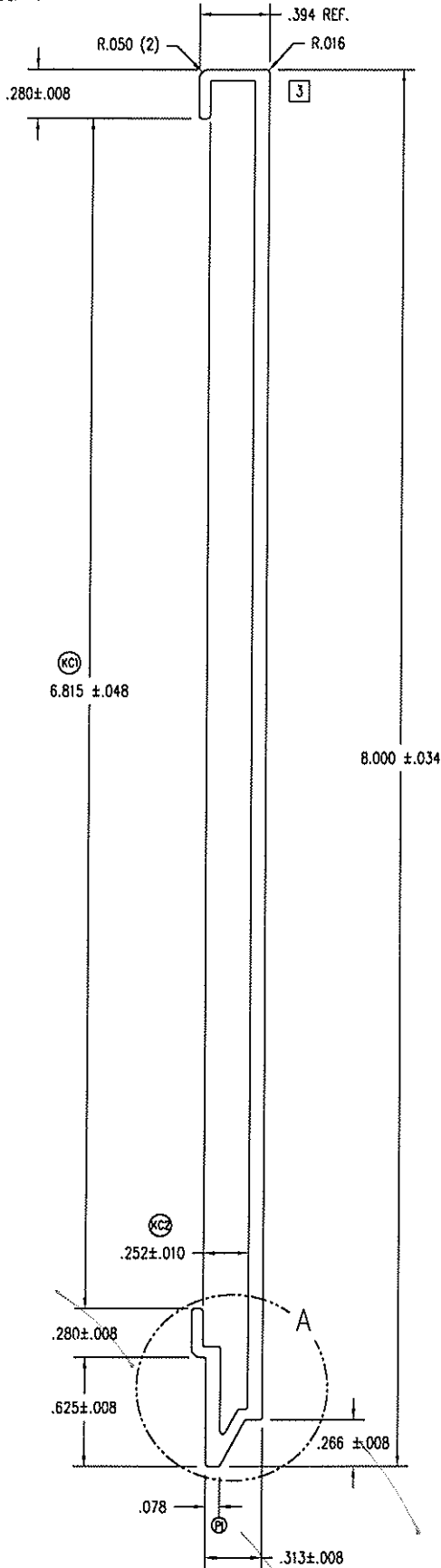

Test sample complies with these details.  
 In addition to the report:  
 Report: 88573/82743  
 Date: 12-08  
 Tech: TC

Architectural Testing

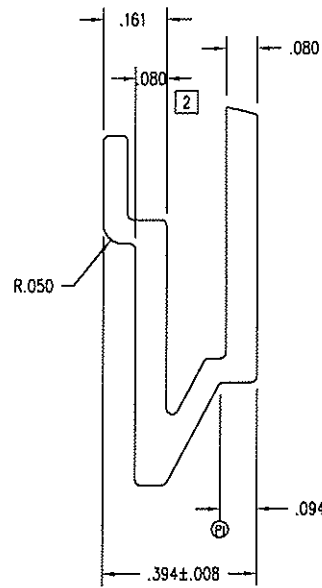

THIS DRAWING AND ITS CONTENTS ARE THE PROPERTY OF EAGLE WINDOW & DOOR. NO USE OR REPRODUCTION OF THE CONTENTS OF THIS DOCUMENT IS PERMITTED WITHOUT THE EXPRESS WRITTEN PERMISSION OF EAGLE WINDOW & DOOR.

TITLE: 8" PANEL CLADDING INTERLOCK FIT  
 FINISH: EAGLE'S STD. COLORS  
 MATL: 6063 T-6 ALUMINUM

03	MADE CORNER RADIUS .015	AWW	PRE	10/7/04			
02	MADE WALL .080, NOT .062	AWW	PRE	6/28/04	DFT:	AWW	SCALE: 1=1
01	REMOVED "BUMPS"	TWN	PRE	5/5/04	DCN:	0736	DRWG: A64K
NO	DESCRIPTION	DFT	DOC	DATE	DATE:	7/14/2003	C 01 OF 02

NOTE: 1. UNLESS OTHERWISE SPECIFIED, ALL DIMENSIONS SHOWN ARE IN INCHES AND ALL TOLERANCES ARE TO BE: DEC. ±.005; FRAC. ±1/64; ANGLES ±1/2'.

PRODUCT	GLASS	A
(PRE '96 & NG) CLAD CASEMENT & AWNING	5/8"	.469
(PRE '96 & NG) CLAD CASEMENT PICTURE	3/4"	.469
CLAD PIANO HINGE CASEMENT	5/8"	.469
CLAD PIANO HINGE CASEMENT (3056 & ABOVE)	3/4"	.469
CLAD RADIUS CASEMENT	5/8" & 3/4"	.469
(PRE '96 & NG) CLAD DOUBLE / SINGLE HUNG	5/8"	.469
(PRE '96 & NG) CLAD DOUBLE HUNG PICTURE	5/8"	.469
CLAD DOUBLE HUNG TRANSOM	5/8"	.469
CLAD DOUBLE HUNG REPLACEMENT SASH	5/8"	.469
ALL CLAD (NON-RADIUS) AUXILIARY (0-15 SQ. FT.)	3/4"	.469
ALL CLAD (NON-RADIUS) AUXILIARY (15+ SQ. FT.)	1"	.469
CLAD SLIDING WINDOW	5/8"	.469
CLAD INSWING / OUTSWING FRENCH DOOR	3/4"	.469
CLAD FRENCH DOOR TRANSOM	3/4"	.469
CLAD PATIO / FRENCH SLIDING DOOR	3/4"	.469
(PRE '98) WOOD CASEMENT & AWNING	3/4"	.680
(PRE '98) WOOD CASEMENT PICTURE	3/4"	.680
(NG) WOOD CASEMENT & AWNING	5/8"	.469
(NG) WOOD CASEMENT PICTURE	5/8" & 3/4"	.469
WOOD PIANO HINGE CASEMENT	5/8"	.469
WOOD PIANO HINGE CASEMENT (3056 & ABOVE)	3/4"	.469
(PRE '96 & NG) WOOD DOUBLE / SINGLE HUNG	5/8"	.469
(PRE '96 & NG) WOOD DOUBLE HUNG PICTURE	5/8"	.469
WOOD SLIDING WINDOW	5/8"	.469
WOOD DOUBLE HUNG TRANSOM	5/8"	.469
WOOD DOUBLE HUNG REPLACEMENT SASH	5/8"	.469
WOOD (NON-RADIUS) AUXILIARY (0-15 SQ. FT.)	3/4"	.469
WOOD (NON-RADIUS) AUXILIARY (15+ SQ. FT.)	1"	.469
WOOD INSWING / OUTSWING FRENCH DOOR	3/4"	.469
WOOD FRENCH DOOR TRANSOM	3/4"	.469
WOOD PATIO / FRENCH SLIDING DOOR	3/4"	.469
CLAD & WOOD PATIO/FR. SLIDING DOOR (BLIND GLASS)	1"	.406
ALL CLAD AND WOOD WINDOWS AND DOORS EXCEPT AUXILIARY UNITS WHICH ALWAYS USES .469	SINGLE GLAZED H. MSTR MONO	.680

**Architectural Testing**  
 Test sample complies with these details.  
 Deviations are noted.  
 Report# 82743, 82573  
 Date 6-12-08 Tech JG

PANEL STOPS		
PRODUCT	A	
WOOD OUTSWING SIDELITE	.469	2
WOOD OUTSWING TRANSOM	.469	
WOOD INSWING SIDELITE	.469	4
WOOD INSWING TRANSOM	.469	
CLAD DHG PICTURE	.406	

1

.062 x .062 CHAMFER

3

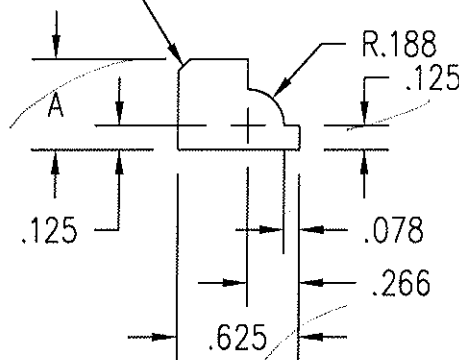

THIS DRAWING AND ITS CONTENTS ARE THE PROPERTY OF EAGLE WINDOW & DOOR. NO USE OR REPRODUCTION OF THE CONTENTS OF THIS DOCUMENT IS PERMITTED WITHOUT THE EXPRESS WRITTEN PERMISSION OF EAGLE WINDOW & DOOR.

TITLE: COLONIAL GLAZING STOP

FINISH:

MATL: EAGLE STD WOOD OFFERINGS

DFT: JMH SCALE: 1=1

DCN: 0650 DRWG: 220J

DATE: 5/29/2002 A 01 OF 03

04	ADDED CDHG PICT TO CHART	KJS	0881	3/6/07
03	ADDED SIZE FOR IMPACT GLAZING	TWN	0972	9/1/05
02	CHG'D CLAD PANEL STOP "A" DIM	JH	0794	6/30/05
01	ADDED KYLER BLIND SIZE	TWN	0910	4/19/05
NO	DESCRIPTION	DFT	DOC	DATE

- NOTE: 1. UNLESS OTHERWISE SPECIFIED, ALL DIMENSIONS SHOWN ARE IN INCHES AND ALL TOLERANCES ARE TO BE: DEC.  $\pm .010$ ; FRAC.  $\pm 1/64$ ; ANGLES  $\pm 1/2^\circ$ .  
 2. WALL THICKNESS .040 UNLESS OTHERWISE SPECIFIED.

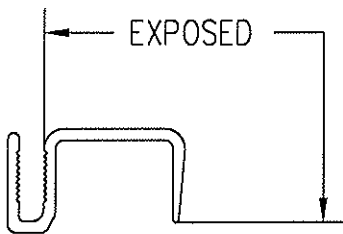
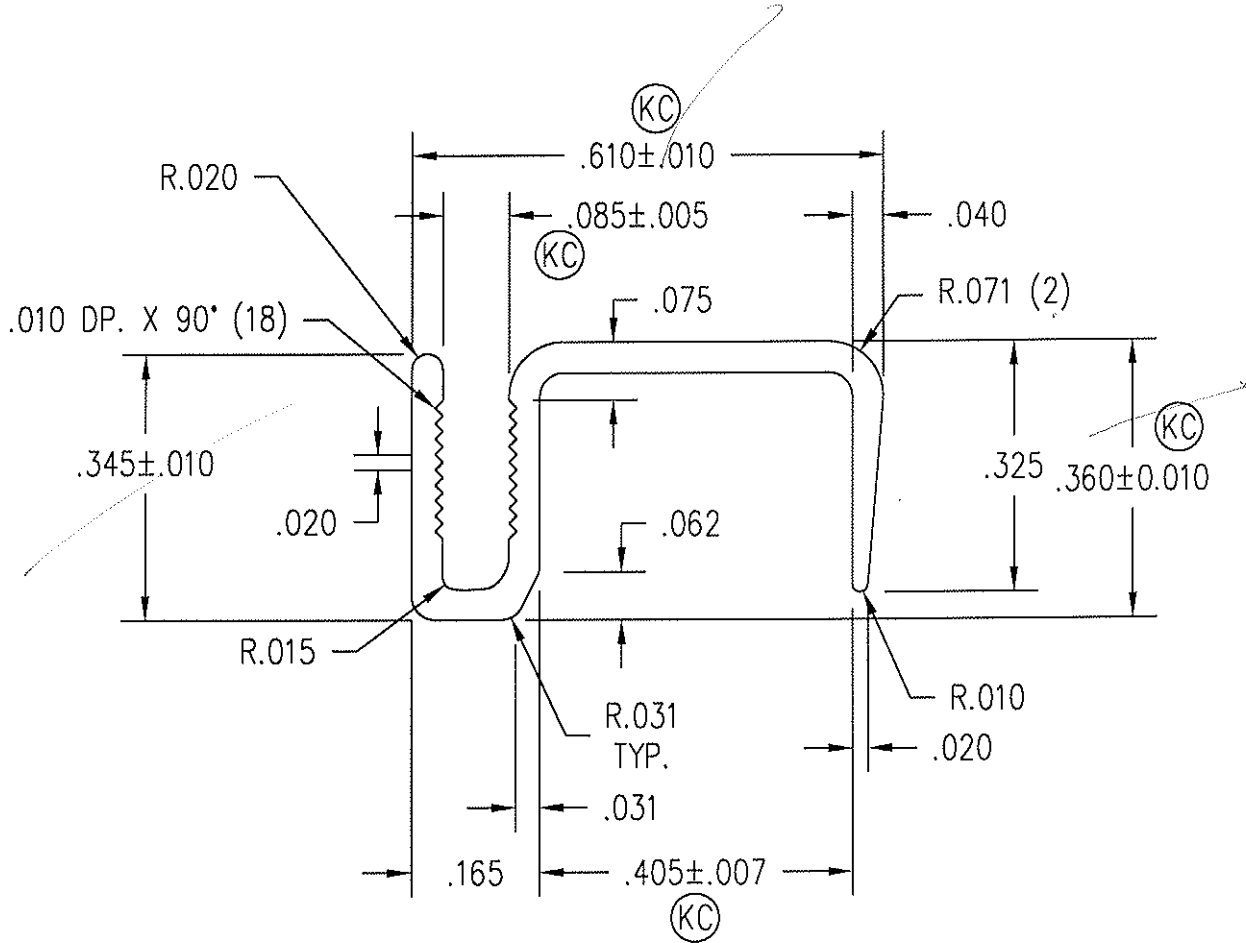

Architectural Testing

Test sample complies with these details.  
 Deviations are noted.

Report# 82743 / 82573  
 Date 6-12-08 Tech 70

THIS DRAWING AND ITS CONTENTS ARE THE PROPERTY OF EAGLE WINDOW & DOOR. NO USE OR REPRODUCTION OF THE CONTENTS OF THIS DOCUMENT IS PERMITTED WITHOUT THE EXPRESS WRITTEN PERMISSION OF EAGLE WINDOW & DOOR.

TITLE: FRENCH DOOR PANEL CAP

FINISH: EAGLE'S STD. COLORS

MATL: 6030 T-6 ALUMINUM

DFT: TWN SCALE: 4=1

DCN: 0838 DRWG: A49X

DATE: 9/7/2001 A 01 OF 02

NO	DESCRIPTION	DFT	DOC	DATE

- NOTE: 1. UNLESS OTHERWISE SPECIFIED, ALL DIMENSIONS SHOWN ARE IN INCHES AND ALL TOLERANCES ARE TO BE: DEC.  $\pm 0.005$ ; FRAC.  $\pm 1/64$ ; ANGLES  $\pm 1/2^\circ$ .  
 2. BREAK ALL CORNERS .015, UNLESS NOTED.

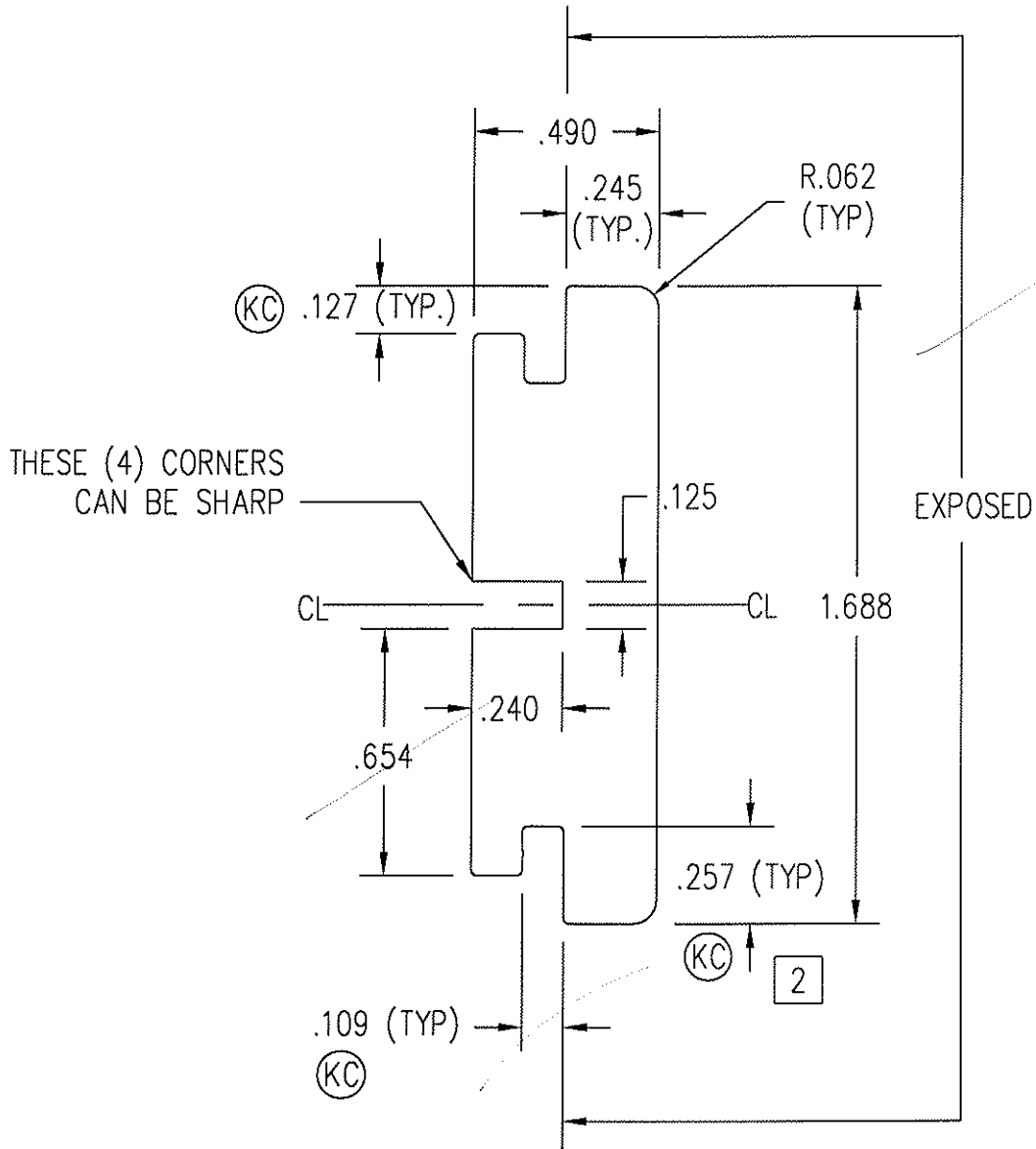

Architectural Testing

Test sample complies with these details.  
 Deviations are noted.

Report# 82743, 82573  
 Date 6-12-08 Tech TC

THIS DRAWING AND ITS CONTENTS ARE THE PROPERTY OF EAGLE WINDOW & DOOR. NO USE OR REPRODUCTION OF THE CONTENTS OF THIS DOCUMENT IS PERMITTED WITHOUT THE EXPRESS WRITTEN PERMISSION OF EAGLE WINDOW & DOOR.

TITLE: INSWING DOOR  
 INTERIOR SILL TRIM

FINISH:

MATL: OAK

02	CHG'D DIM. FROM .247 TO .257	TWN	1022A	7/31/06	DFT: AWW	SCALE: 2=1
01	MADE PROFILE SYMMETRICAL	AWW	1022	5/17/06	DCN: 0794	DRWG: 2225
NO	DESCRIPTION	DFT	DOC	DATE	DATE: 4/14/2003	A 01 OF 02

- NOTE: 1. UNLESS OTHERWISE SPECIFIED, ALL DIMENSIONS SHOWN ARE IN INCHES AND ALL TOLERANCES ARE TO BE: DEC.  $\pm 0.030$ ; FRAC.  $\pm 1/64$ ; ANGLES  $\pm 1/2^\circ$ .
2. APPROVED VENDOR: CLIM-A-TEK.
3. "A2" PRESSURE SENSITIVE ADHESIVE. 1
4. LEFT & RIGHT REQUIRED (1 EA. PER DOOR), LEFT SHOWN.
5. PART NO: 80236

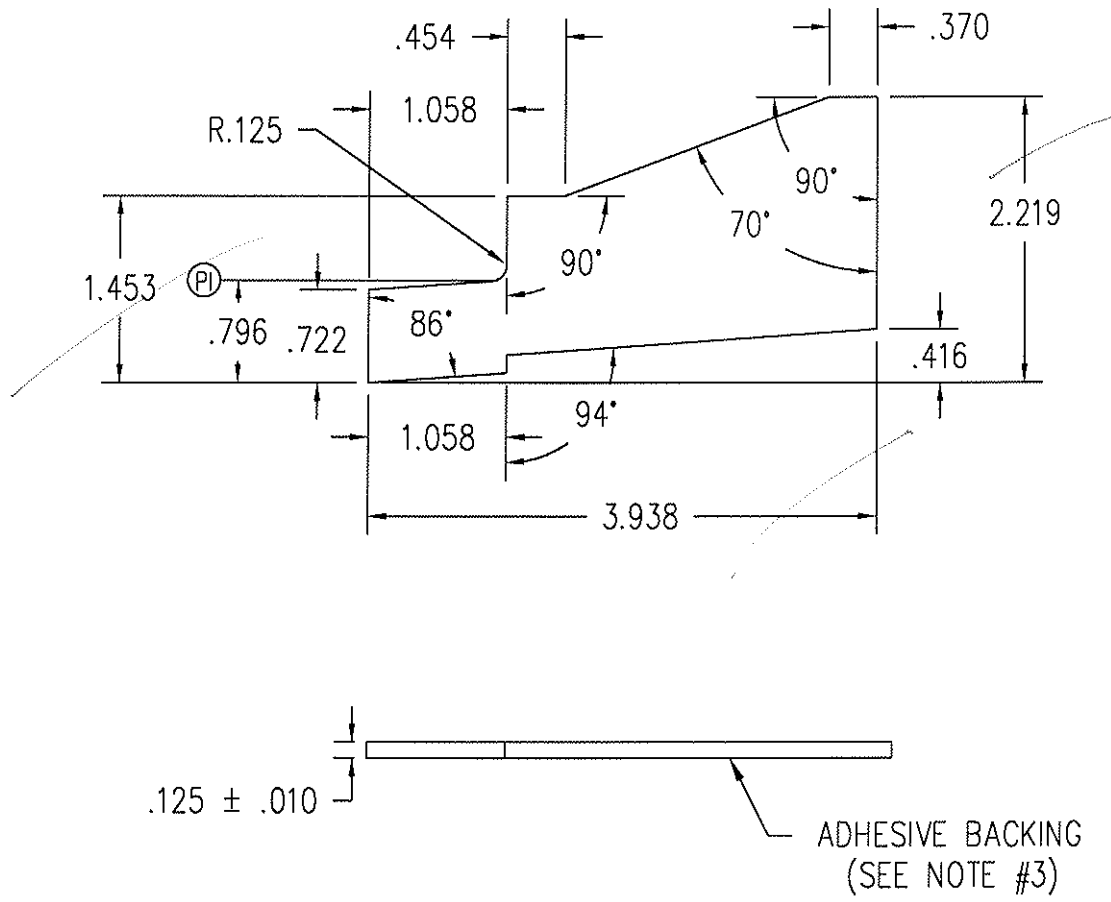

**Architectural Testing**

Test sample complies with these details.  
 Deviations are noted.

Report# 82573 / 82743

Date 6-12-08 Tech JL

THIS DRAWING AND ITS CONTENTS ARE THE PROPERTY OF EAGLE WINDOW & DOOR. NO USE OR REPRODUCTION OF THE CONTENTS OF THIS DOCUMENT IS PERMITTED WITHOUT THE EXPRESS WRITTEN PERMISSION OF EAGLE WINDOW & DOOR.	
TITLE: 4 9/16" SILL JAMB SIDE PAD	
FINISH:	
MATL: BLACK 11# PVC FOAM	
DFT: TWN	SCALE: 1=1 1/2
DCN: 0794	DRWG: A622
DATE: 9/24/2003	A 01 OF 01

01	CHANGED ADHESIVE NOTE	TWN	1125	8/15/07
NO	DESCRIPTION	DFT	DOC	DATE

- NOTE: 1. UNLESS OTHERWISE SPECIFIED, ALL DIMENSIONS SHOWN ARE IN INCHES AND ALL TOLERANCES ARE TO BE: DEC.  $\pm 0.010$ ; FRAC.  $\pm 1/64$ ; ANGLES  $\pm 1/2^\circ$ .
2. NO TELEGRAPHING (VISIBILITY) OF CORE GLUE JOINTS THROUGH ANY EXPOSED VENEER SURFACE IS ALLOWED.
3. ACCEPTABLE MATERIAL FOR THIS PART WHEN USED IN STAIN GRADE FINAL PRODUCT (i.e.; UNFINISHED, CLEAR FINISHED, STAINED, OR STAINED AND CLEAR FINISHED) IS DEFINED ON DRAWING 20CG.
- ACCEPTABLE MATERIAL FOR THIS PART WHEN USED IN PAINT GRADE FINAL PRODUCT (i.e.; INTERIOR PRIMED OR INTERIOR PAINTED) INCLUDES ANY OF THE FOLLOWING:
- A. AS DEFINED ON DRAWING 20CG.
- B. EDGE GLUED, FINGER-JOINTED, OR EDGE GLUED AND FINGER JOINTED PINE (SUGAR AND/OR PONDEROSA). ALL GLUED JOINTS MUST BE ADHERED USING AN EXTERIOR GRADE TYPE I BOND ADHESIVE. BROWN AND BLUE STAIN PARTS ARE NOT PERMITTED. SINKER STOCK IS NOT PERMITTED. NO KNOTS OR PITCH POCKETS ARE ALLOWED ON EXPOSED SURFACES. LESS THAN OR EQUAL TO 10% OF MATERIAL IN UNEXPOSED AREA MAY HAVE SMALL (LESS THAN 1/4" DIA.), SOLID, TIGHT KNOTS AND SMALL PITCH POCKETS (LESS THAN 1/4" DIA. x 1/2" LENGTH).

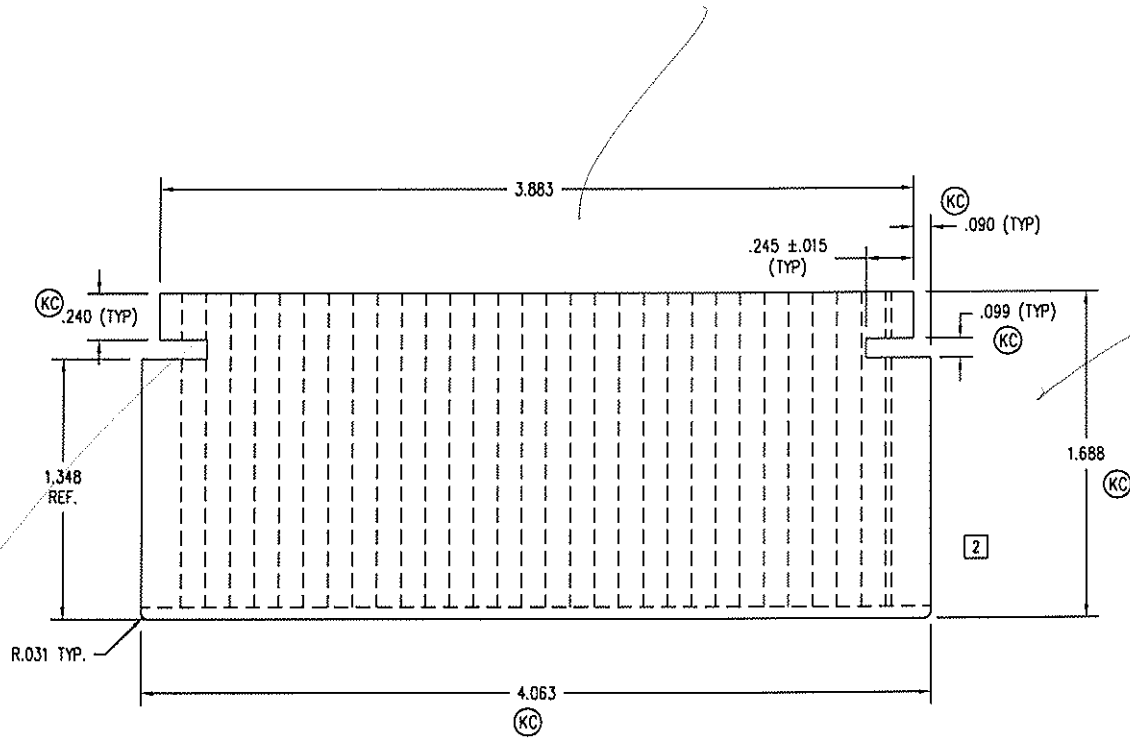

### Architectural Testing

Test sample conforms with these details.  
 Deviations are noted.

Revised 82473, 82573  
 Date 6-12-08 Tech: TG



THIS DRAWING AND ITS CONTENTS ARE THE PROPERTY OF  
 EAGLE WINDOW & DOOR. NO USE OR REPRODUCTION OF THE  
 CONTENTS OF THIS DOCUMENT IS PERMITTED WITHOUT THE  
 EXPRESS WRITTEN PERMISSION OF EAGLE WINDOW & DOOR.

TITLE: 4 11/16" STILE / RAIL

FINISH: PRESERVATIVE (SEE A02J)  
 ALSO (INT. A02E)

NO	DESCRIPTION	DFT	DOC	DATE	DATE	MATL:	SCALE:
04	CHNG'D PROFILE	TWN	PRE	3/22/05		SEE NOTE #3	
03	104 (TYP) READ 086	AWW	PRE	10/18/04			
02	REMYD ANGLE FROM GLASS SHL	AWW	PRE	10/3/04	DFT: TWN	SCALE: 1=1	
01	CHNGD TO MATCH 20A1	AWW	PRE	6/28/04	DCN: 0736	DRWG: 20D6	
		DFT	DOC	DATE	DATE: 8/28/2003	C	01 OF 08

- NOTE: 1. UNLESS OTHERWISE SPECIFIED, ALL DIMENSIONS SHOWN ARE IN INCHES AND ALL TOLERANCES ARE TO BE: DEC.  $\pm 0.005$ ; FRAC.  $\pm 1/64$ ; ANGLES  $\pm 1/2^\circ$ .  
 2. WALL THICKNESS TO BE  $.062$  UNLESS OTHERWISE SPECIFIED.  
 3. ALL CORNERS TO BE  $.015$  UNLESS OTHERWISE SPECIFIED.  
 4. AREA =  $.390$  SQ. IN.

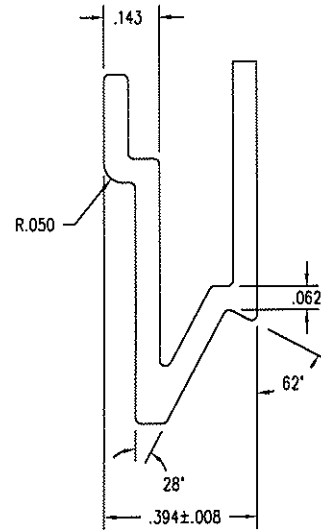
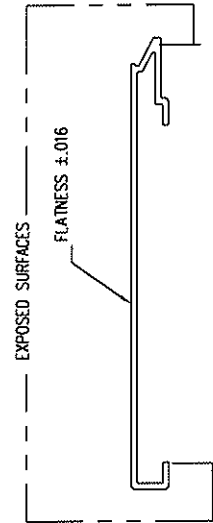
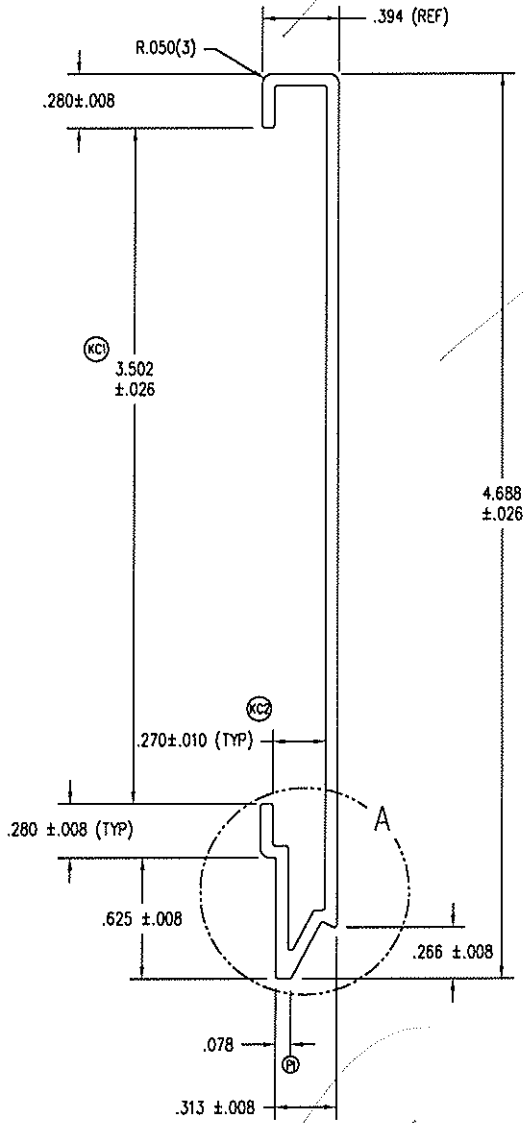

DETAIL A  
SCALE: 2 = 1



Architectural Testing

Test sample complies with these details.  
 External use only.

Report# 82743 82573  
 Date 6-12-08 Tech JB

THIS DRAWING AND ITS CONTENTS ARE THE PROPERTY OF EAGLE WINDOW & DOOR. NO USE OR REPRODUCTION OF THE CONTENTS OF THIS DOCUMENT IS PERMITTED WITHOUT THE EXPRESS WRITTEN PERMISSION OF EAGLE WINDOW & DOOR.	
TITLE: 4 11/16" PANEL CLADDING INTERLOCK FIT	
FINISH: EAGLE'S STD. COLORS	
MATERIAL: 6063 T-6 ALUMINUM	
DFT: AWW	SCALE: 1=1
DCN: 0794	DRWG: A613
NO: 7/14/2003	DATE: 7/14/2003 C 01 OF 06

NO	DESCRIPTION	DFT	DOC	DATE
7/14/2003				

- NOTE: 1. UNLESS OTHERWISE SPECIFIED, ALL DIMENSIONS SHOWN ARE IN INCHES AND ALL TOLERANCES ARE TO BE: DEC.  $\pm 0.010$ ; FRAC.  $\pm 1/64$ ; ANGLES  $\pm 1/2^\circ$ .
2. NO TELEGRAPHING (VISIBILITY) OF CORE GLUE JOINTS THROUGH ANY EXPOSED VENEER SURFACE IS ALLOWED.
3. ACCEPTABLE MATERIAL FOR THIS PART WHEN USED IN STAIN GRADE FINAL PRODUCT (i.e.; UNFINISHED, CLEAR FINISHED, STAINED, OR STAINED AND CLEAR FINISHED) IS DEFINED ON DRAWING 200R.
- ACCEPTABLE MATERIAL FOR THIS PART WHEN USED IN PAINT GRADE FINAL PRODUCT (i.e.; INTERIOR PRIMED OR INTERIOR PAINTED) INCLUDES ANY OF THE FOLLOWING:
- A. AS DEFINED ON DRAWING 200R.
- B. EDGE GLUED, FINGER-JOINTED, OR EDGE GLUED AND FINGER JOINTED PINE (SUGAR AND/OR PONDEROSA). ALL GLUED JOINTS MUST BE ADHERED USING AN EXTERIOR GRADE TYPE I BOND ADHESIVE. BROWN AND BLUE STAIN PARTS ARE NOT PERMITTED. SINKER STOCK IS NOT PERMITTED. NO KNOTS OR PITCH POCKETS ARE ALLOWED ON EXPOSED SURFACES. LESS THAN OR EQUAL TO 10% OF MATERIAL IN UNEXPOSED AREA MAY HAVE SMALL (LESS THAN 1/4" DIA.), SOLID, TIGHT KNOTS AND SMALL PITCH POCKETS (LESS THAN 1/4" DIA. x 1/2" LENGTH).

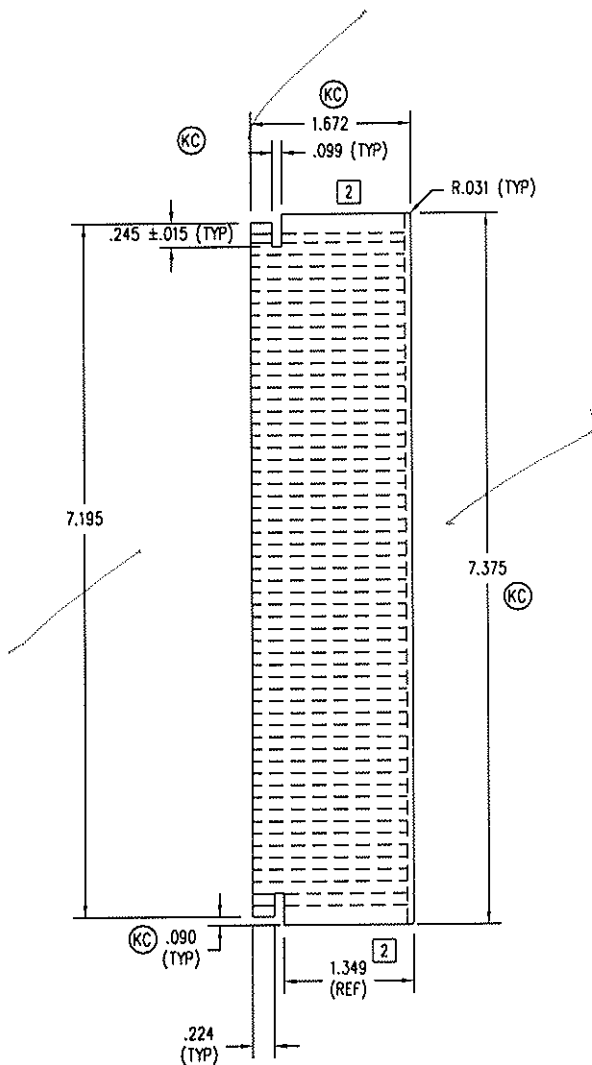

Architectural Testing

Test sample complete with test cells.  
 Description: 82573, 82743  
 Report# 82573, 82743  
 Date 6-12-08 Tech JZ

THIS DRAWING AND ITS CONTENTS ARE THE PROPERTY OF EAGLE WINDOW & DOOR. NO USE OR REPRODUCTION OF THE CONTENTS OF THIS DOCUMENT IS PERMITTED WITHOUT THE EXPRESS WRITTEN PERMISSION OF EAGLE WINDOW & DOOR.

TITLE: 8" BOTTOM RAIL  
 FINISH: PRESERVATIVE (SEE A02J) ALSO (INT. A02F)  
 SEE NOTE #3

NO	DESCRIPTION	DFT	DOC	DATE	DATE	DATE	DATE
04	CHNG'D PROFILE	TWN	PRE	3/22/05	MATL:		
03	.073 WAS .056	AWW	PRE	10/18/04			
02	.015 WAS .094, RM'VD ANGLE	AWW	PRE	10/7/04	DFT:	TWN	SCALE: 1=2
01	CHNG'D TO MATCH 2009	AWW	PRE	6/30/2004	DCN:	0736	DRWG: 200J
					DATE:	3/31/2004	C 01 OF 02