

**AAMA/WDMA/CSA 101/I.S.2/A440-08
TEST REPORT**

Rendered to:

EAGLE WINDOWS & DOOR, INC

**PRODUCT TYPE: Ascent Series 2080
Clad Out-Swing Sidelite (SL1M1 Center Rail)
SERIES/MODEL: Aluminum Clad
Wood Sidelite with Center Rail**

Title	Summary of Results
Primary Product Designator	LC-PG80-SLT 610 x 2413 (24 x 95)
Design Pressure	± 3840 Pa (± 80.0 psf)
Air Infiltration	0.51 L/s/m ² (0.02 cfm/ft ²)
Water Penetration Resistance Test Pressure	580 Pa (12.0 psf)
Uniform Load Structural Test Pressure	$5760 \pm$ Pa (± 120.0 psf)
Forced Entry Resistance	Grade 40

Test Completion Date: 11/09/06

Reference must be made to Report No. 68741.01-201-44, dated 12/01/08 for complete test specimen description and data.

AAMA/WDMA/CSA 101/I.S.2/A440-08 TEST REPORT

Rendered to:

EAGLE WINDOW & DOOR, INC.
2045 Kerper Boulevard, P.O. Box 1072
Dubuque, Iowa 52004-1072

Report No.: 68741.01-201-44
Test Dates: 11/08/06
Through: 11/09/06
Original Report Date: 11/27/06
Revised Report Date: 12/01/08
Expiration Date: 11/08/10

Project Summary: Architectural Testing, Inc. was contracted by Eagle Window & Door to perform testing on a Series/Model Ascent Series 2080 Clad Out-Swing Sidelite (SL1M1 Center Rail), Aluminum Clad Wood Sidelite with Center Rail. The sample tested successfully met the performance requirements for a LC-PG80-SLT 610 x 2413 (24 x 95) rating. Test specimen description and results are reported herein.

Test Specification: The test specimen was evaluated in accordance with AAMA/WDMA/CSA 101/I.S.2/A440-08, *NAFS - North American Fenestration Standard/Specification for Windows, Doors, and Skylights*.

Test Specimen Description:

Series/Model: Ascent Series 2080 Clad Out-Swing Sidelite (SL1M1 Center Rail)

Product Type: Aluminum Clad Wood Sidelite with Center Rail

Overall Size: 610 mm (24") wide by 2421 mm (95-5/16") high

Panel Size: 564 mm (22-3/16") wide by 2367 mm (93-3/16") high

Overall Area: 1.5 m² (15.9 ft²)

Finish: Interior is natural wood, exterior cladding is painted.

Test Specimen Description: (Continued)

Frame Construction: The frame was comprised of aluminum extrusions slip fit over wood side and head jambs. At the head, the aluminum frame joints were mitered, sealed with silicone and secured by a corner key. The wood jambs were sealed with silicone and fastened with three #8 by 34 mm (1-3/4") screws per corner. The sill was comprised of an aluminum extrusion slip-fit over a polyethylene/wood fiber composite material with an oak threshold. The sill was butted to the side jamb, sealed with silicone and fastened with three # 8 by 44 mm (1-3/4") screws per corner.

Panel Construction: The panel members were composed of laminated veneer lumber (LVL) with a veneer wrap. The corner construction consisted of square cut, glued and doweled construction and secured with one 64 mm (2-1/2") brad. The mid rail is similarly constructed with glued wooden dowels and secured with one 64 mm (2-1/2") brad. The extruded aluminum cladding was square cut, silicone sealed and press-fit to the wood panel members. The panel was secured to the frame with rigid PVC dual-durometer continuous spacer bracket that was secured to the frame with #8 by 19 mm (3/4") screws spaced 76 mm to 152 mm (3" to 6") from corners and (14" to 16") on center. The panel was set in a bed of perimeter sealant and secured through the spacer bracket with #8 by 25 mm (1") screws spaced to 152 mm (3" to 6") from corners and (14" to 16") on center.

Glazing Details: Each of the two lights glazing utilized two nominal 3 mm (1/8") thick tempered sheets separated by a 13 mm (1/2") metal spacer system. The glass was set from the interior against a 13 mm (1/2") by 2 mm (1/16") thick butyl glazing tape and a back-bedding of silicone. Interior wood stops with a 16 mm (5/8") by 2 mm (1/16") thick single sided foam tape were utilized on the interior and secured with a 32 mm (1-1/4") 18 gauge brad nail 51 mm (2") from the corners and spaced 152 mm to 203 (6" to 8") on center.

Weatherstripping:

<u>Description</u>	<u>Quantity</u>	<u>Location</u>
6 mm (1/4") diameter hollow bulb	1 Row	Top rail of panel

Installation: The unit was installed within a nominal wood test buck. The door was attached to the buck with the nailing fin with 51 mm (2") roof nails spaced 152 mm (6") from each corner and spaced 152 mm (6") on center. The unit was additionally installed with #8 by 76 mm (3") screws through the frame spaced 152 mm (6") from each corner and 305 mm (12") on center. The sill was set in a bed of silicone sealant. The unit was sealed to the buck with silicone sealant.

Test Results: The temperature during testing was 21°C (70°F). The results are tabulated as follows:

<u>Paragraph</u>	<u>Title of Test - Test Method</u>	<u>Results</u>	<u>Allowed</u>
5.3.2	Air Leakage Resistance per ASTM E 283		
	75 Pa (1.6 psf)	0.10 L/s/m ² (0.02 cfm/ft ²)	1.5 L/s/m ² (0.3 cfm/ft ² max.)
	300 Pa (6.2 psf)	0.51 L/s/m ² (0.10 cfm/ft ²)	-- --

Note #1: *The tested specimen meets (or exceeds) the performance levels specified in AAMA/WDMA/CSA 101/I.S.2/A440-08 for air leakage resistance.*

5.3.3.2	Water Penetration Resistance per ASTM E 547		See Note #2
5.3.4.2	Uniform Load Deflection per ASTM E 330		See Note #2
5.3.4.3	Uniform Load Structural per ASTM E 330		See Note #2

Note #2: *The client opted to start at a pressure higher than the minimum required. Those results are listed under "Optional Performance".*

5.3.5	Forced Entry Resistance per ASTM F 588		
	Type: D	Grade: 40	
	Lock Hardware Manipulation Test	No entry	No entry
	Sash/Panel Manipulation Test	No entry	No entry

Optional Performance

4.3.2.1	Water Penetration Resistance per ASTM E 547		
	580 Pa (12.0 psf)	No leakage	No leakage
4.3.2.1	Uniform Load Deflection per ASTM E 330 (Deflections were taken on the panel bottom rail) (Loads were held for 60 seconds)		
	3840 Pa (80.0 psf) (positive)	<0.3 mm (<0.01")	See Note #3
	3840 Pa (80.0 psf) (negative)	<0.3 mm (<0.01")	See Note #3

Note #3: *The deflections reported are not limited by AAMA/WDMA/CSA 101/I.S.2/A440-08 for this product designation. The deflection data is recorded in this report for special code compliance and information only.*

Test Results: (Continued)

<u>Paragraph</u>	<u>Title of Test - Test Method</u>	<u>Results</u>	<u>Allowed</u>
<u>Optional Performance</u> (Continued)			
4.3.2.1	Uniform Load Structural per ASTM E 330 (Permanent sets were taken on the panel bottom rail) (Loads were held for 10 seconds)		
	5760 Pa (120.0 psf) (positive)	0.3 mm (0.01)	2.3 mm (0.09") max.
	5760 Pa (120.0 psf) (negative)	<0.3 mm (<0.01")	2.3 mm (0.09") max.

Tape and film were used to seal against air leakage during structural testing. In our opinion, the tape and film did not influence the results of the test.

Drawing Reference: The test specimen drawings have been reviewed by Architectural Testing and are representative of the test specimen reported herein.

List of Official Observers:

<u>Name</u>	<u>Company</u>
Karl A. Lips-Eakins	Architectural Testing, Inc.
Eric J. Schoenthaler	Architectural Testing, Inc.

Detailed drawings, data sheets, representative samples of test specimens, a copy of this report, or other pertinent project documentation will be retained by Architectural Testing, Inc. for a period of four years from the original test date. At the end of this retention period, such materials shall be discarded without notice and the service life of this report will expire.

Results obtained are tested values and were secured by using the designated test methods. No conclusions of any kind regarding the adequacy or inadequacy of the glass in the test specimen can be made. This report does not constitute certification of this product nor an opinion or endorsement by this laboratory. It is the exclusive property of the client so named herein and relates only to the specimens tested. This report may not be reproduced, except in full, without the written approval of Architectural Testing, Inc.

For ARCHITECTURAL TESTING, INC.

Eric J. Schoenthaler
Project Manager

Daniel A. Johnson
Director - Regional Operations

EJS/mb

Attachments (pages): This report is complete only when all attachments listed are included.

Appendix A: Alteration Addendum (1)

Appendix B: WDMA Submittal Forms (2)

Appendix C: Drawings (24)

Revision Log

<u>Rev. #</u>	<u>Date</u>	<u>Page(s)</u>	<u>Revision(s)</u>
0	11/27/06	N/A	Original report issue. Report and drawings forwarded to AMS for Hallmark Certification.
1	01/25/07	3	Added Forced Entry Resistance Data. Report and drawings forwarded to AMS for Hallmark Certification.
2	12/01/08	All	Test report results conducted prior to 2008 standard being published, report is as compared to 2008 standard. Report and drawings forwarded to AMS for Hallmark Certification.

Appendix A:
Alteration Addendum

Note: No alterations were required.

Appendix B
WDMA Submittal Forms



WDMA HALLMARK CERTIFICATION PROGRAM REPORT SUBMISSION FORM

THIS FORM IS TO BE COMPLETED BY THE MANUFACTURER AND SUBMITTED TO AMS PRIOR TO OR ALONG WITH SUBMISSION OF EACH NEW OR REVISED TEST REPORT FOR CERTIFICATION TO THE HALLMARK PROGRAM. ANY QUESTIONS PLEASE CONTACT AMS AT 315-646-2234 OR staff@amscert.com.

Manufacturer: Eagle Window and Door, Inc.

Contact: Todd Bergstrom

Plant Location(s):
(list all plants where product is made)
2045 Kerper Blvd. Dubuque, IA 52004-1072

Phone: 563-556-2270

Test Report #: 68741.01-201-44-R2

Email: tbergstrom@eaglewindow.com

Product Relationship:

Extension of currently certified product? yes no n/a Recertification New (check one)

If yes, what CCL # ? 099-H-668.00

Difference from Certified Product: Report re-written to A440.08 standard.

Is this a Gateway Test ? yes no n/a

Does this report require a Gateway Report # ? yes no n/a Report #: _____

Impact Report:

If this is not an impact report check here:

AWS Report # _____

Test Plan # ? yes no n/a _____

Installation Instructions submitted ? yes no n/a

Certification to Florida:

If this will not be submitted to Florida check here:

AMS to Input to Database yes no n/a

Manufacturer to input yes no n/a



WDMA HALLMARK CERTIFICATION PROGRAM REPORT SUBMISSION FORM

Product Name: Aluminum Clad Wood Sidelight With Center Rail
(as to be listed on CCL)

Product Type: Sidelight

Additional Manufacturer ID #: _____

n/a

<u>Hallmark CCL</u>	<u>Standard</u>	<u>Rating</u>
<input type="checkbox"/>	ANSI/AAMA/NWWDA 101/I.S. 2 97	_____
<input type="checkbox"/>	101/I.S.2/NAFS-02	_____
<input type="checkbox"/>	AAMA/WDMA/CSA/101/I.S.2/A440-05	_____
<input checked="" type="checkbox"/>	AAMA/WDMA/CSA/101/I.S.2/A440-08	LC-PG80-SLT +80 / -80
<input type="checkbox"/>	ASTM E 1996 99 / E1886-97	_____
<input type="checkbox"/>	ASTM E 1996 01 / E1886-97	_____
<input type="checkbox"/>	ASTM E 1996 02 / E1886-02	_____
<input type="checkbox"/>	ASTM E 1996 03 / E1886-02	_____
<input type="checkbox"/>	ASTM E 1996 04 / E1886-04	_____
<input type="checkbox"/>	ASTM E 1996 05 / E1886-05	_____
<input type="checkbox"/>	ASTM E330 02	_____
<input type="checkbox"/>	ANSI A250.13-03	_____
<input type="checkbox"/>	TAS 201-94	_____
<input type="checkbox"/>	TAS 202-94	_____
<input type="checkbox"/>	TAS 203-94	_____
<input type="checkbox"/>	Other:	_____

Appendix C

Drawings

- NOTE: 1. SEAL MARGIN AT SILL WITH 1/8" DIA. BEAD OF SILICONE SEALANT.
 2. 1/8" BEAD OF SILICONE TO SEAL JOINT BETWEEN JAMB AND SILL.
 3. SCREWS SPACED 1 1/2" FROM EACH END AND 14-16" ON CENTER THEREAFTER.
 4. APPLY 3/16" BEAD OF SILICONE TO ENTIRE LENGTH OF "SIDELITE/TRANSOM SHIM."
 5. SEAL MARGIN AT SILL WITH 1/8" DIA BEAD OF SILICONE SEALANT.



Architectural Testing

Test sample complies with these details.
 Deviations are noted.

Report# 68741
 Date 11/8-9/06 Tech JPK

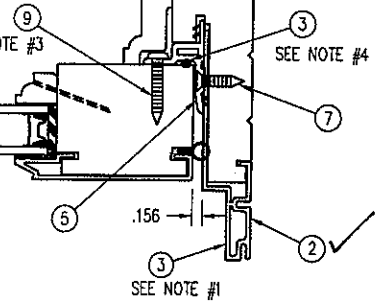
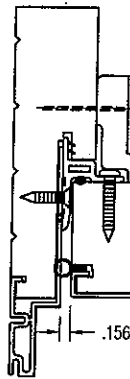

SECTION B - B

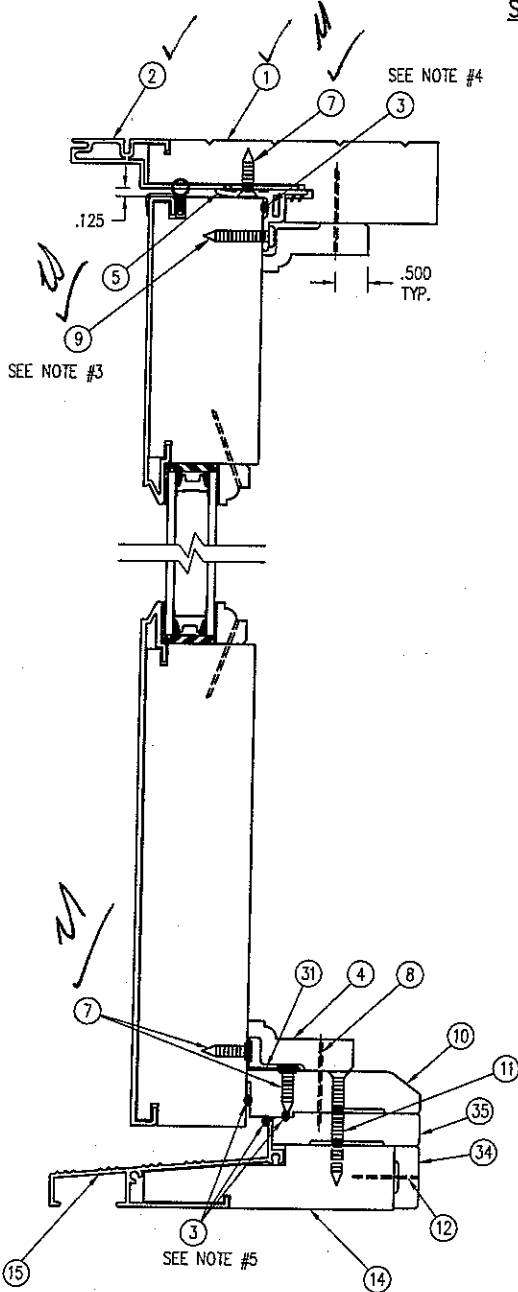

SECTION A-A

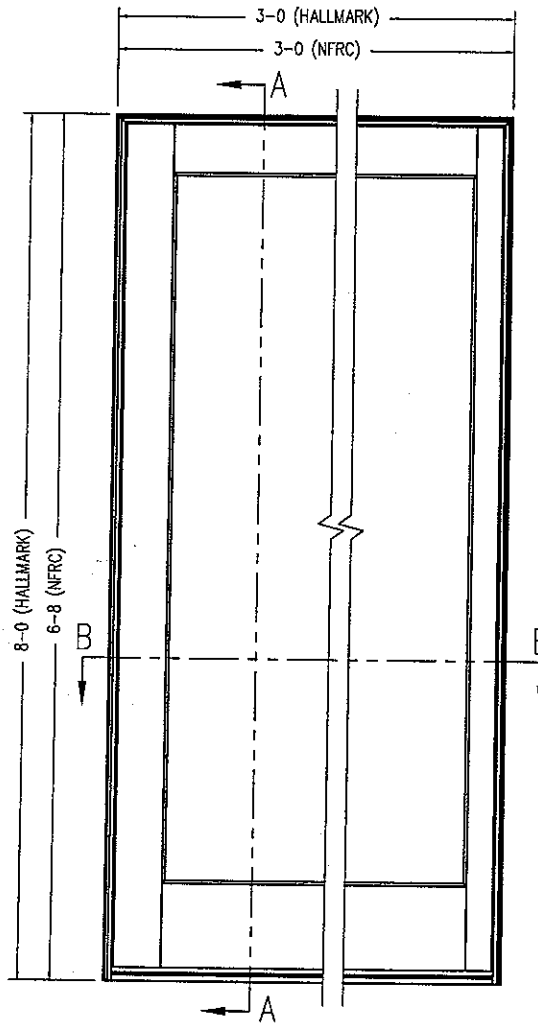

EXTERIOR VIEW
 ELEVATION SHOWN
 W/ 4 11/16" & 2 3/4" STILES

THIS DRAWING AND ITS CONTENTS ARE THE PROPERTY OF EAGLE WINDOW & DOOR. NO USE OR REPRODUCTION OF THE CONTENTS OF THIS DOCUMENT IS PERMITTED WITHOUT THE EXPRESS WRITTEN PERMISSION OF EAGLE WINDOW & DOOR.	
TITLE: CHDFO - SIDELITE UNIT ASSEMBLY	
FINISH:	
MAIL:	
DFI: TWN	SCALE: 1=3
DCN: 0836	DRWG: 0464
DATE: 6/07/05	C 01 OF 07

NO	DESCRIPTION	IFT	DOC	DATE

TOP VIEW

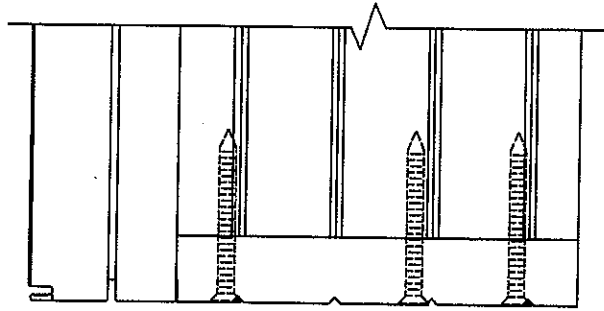

SIDE VIEW

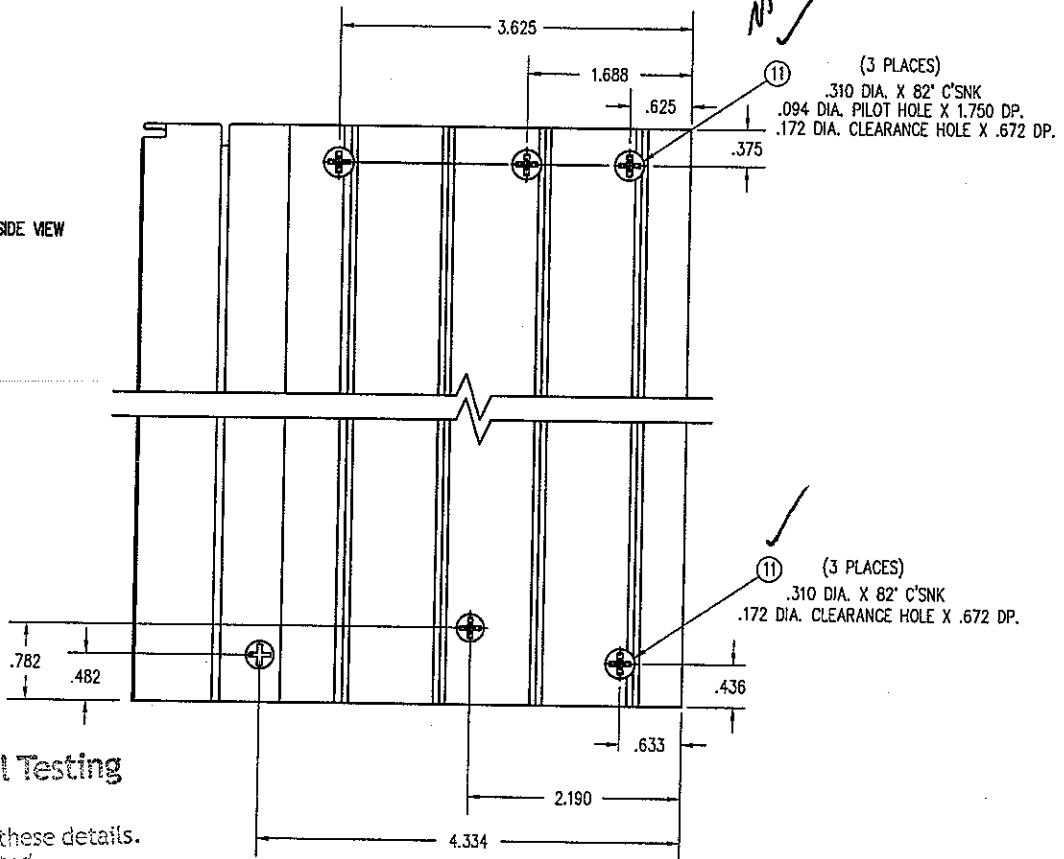

Architectural Testing

Test sample complies with these details.
Deviations are noted.

Report# 68741

Date 11/8-9/06 Tech gpk

BOTTOM VIEW

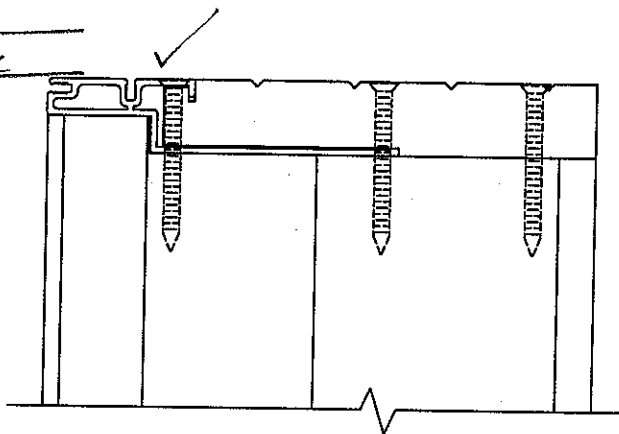

THIS DRAWING AND ITS CONTENTS ARE THE PROPERTY OF EAGLE WINDOW & DOOR. NO USE OR REPRODUCTION OF THE CONTENTS OF THIS DOCUMENT IS PERMITTED WITHOUT THE EXPRESS WRITTEN PERMISSION OF EAGLE WINDOW & DOOR.			
TITLE:		CHDO - SIDEITE UNIT ASSEMBLY	
FINISH:			
MATERIAL:			
DFT:	TWN	SCALE:	1=2
DCN:	0836	DRWG:	0464
DATE:	6/07/05	C	03

NO	DESCRIPTION	DFT	DOC	DATE

NOTE: 1. APPLY A THIN COAT OF GLUE TO ENTIRE SURFACE OF STILE HOLE AND DOWEL PRIOR TO ASSEMBLING PANEL.

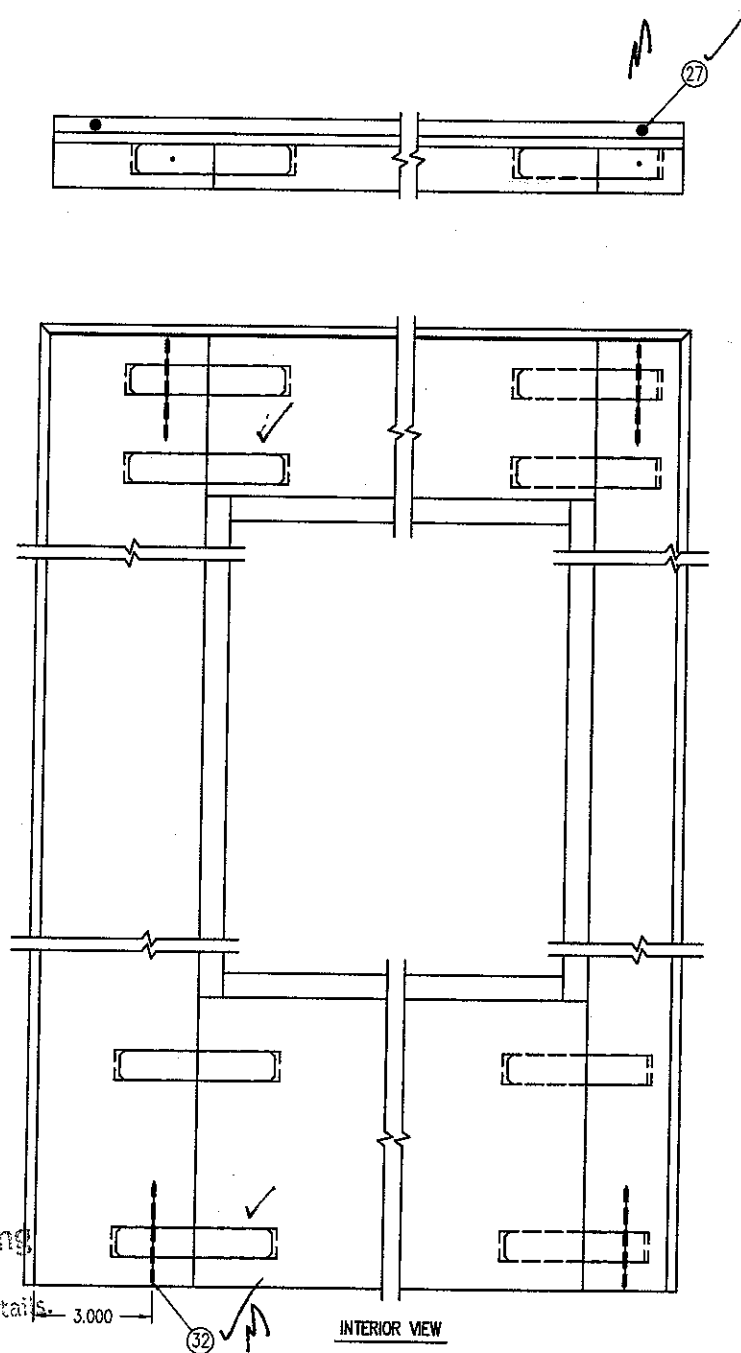

INTERIOR VIEW

Architectural Testing

Test sample complies with these details.
Deviations are noted.

Report# 68741

Date 11/8-9/06 Tech JPK

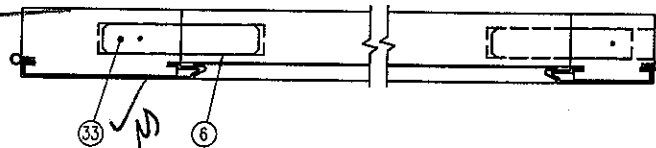

SHOWN WITH BOTH 4 11/16" & 2 3/4" STILES

THIS DRAWING AND ITS CONTENTS ARE THE PROPERTY OF EAGLE WINDOW & DOOR. NO USE OR REPRODUCTION OF THE CONTENTS OF THIS DOCUMENT IS PERMITTED WITHOUT THE EXPRESS WRITTEN PERMISSION OF EAGLE WINDOW & DOOR.			
TITLE: CHDVO - SIDELITE PANEL ASSEMBLY			
FINISH:			
MATERIAL:			
DFT:	TWN	SCALE:	1=5
DCN:	0836	DRWG:	0464
DATE:	6/08/05	C	05

NO	DESCRIPTION	DFT	DOC	DATE

NO.	DWG. NO.	PART DESCRIPTION	QUANTITY	MATERIAL	SUPPLIER
1	206X	JAMB	3	WOOD (FJ)	EAGLE WINDOW & DOOR
2	A04B	JAMB CLADDING	3	ALUMINUM	BONNELL
3	A030	SILICONE SEALANT	AS REQUIRED	SILICONE	DOW CORNING
4	20EJ	SIDELITE / TRANSOM PANEL STOP	4	WOOD	EAGLE WINDOW & DOOR
5	A692	SIDELITE / TRANSOM SHIM	3	PVC	CLIM-A-TECH
6	A01D	WOOD ADHESIVE	AS REQUIRED	COPOLYMER	NATIONAL STARCH
7	A693	#8 X 3/4" FHWS TEKS POINT S.S.	AS REQUIRED	STAINLESS STEEL	ABILITY FASTENERS
8	A40F	1 1/4" 18GA HARD STL BRAD	AS REQUIRED	STEEL	ABILITY FASTENERS
9	A54M	#8 X 1" PPH SMS TEKS POINT S.S.	AS REQUIRED	STAINLESS STEEL	ABILITY FASTENERS
10	21H4	OUTSWING SIDLITE SILL STOP	1	WOOD	EAGLE WINDOW & DOOR
11	A02E	#8 x 1 3/4" FHWS Z & Y	AS REQUIRED	STEEL	ABILITY FASTENERS
12	A40E	1" 18GA HARD STL BRAD	AS REQUIRED	STEEL	ABILITY FASTENERS
13	A61P	5 5/16" MID-RAIL CLADDING INTERLOCK FIT	1 OR 2	ALUMINUM	BONNELL
14	A476	COMPOSITE O/S SUB-SILL	1	WOOD/PLASTIC	ITC
15	A477	O/S FD SILL	1	ALUMINUM	BONNELL
16	A129	CORNER KEY O/S FD	2	ZINC	DECO PRODUCTS CO.
17					
18	20D5	2 3/4" STILE	2	WOOD	PAC. WOOD LAMINATES
	20D6	4 11/16" STILE	1 OR 3	WOOD	PAC. WOOD LAMINATES
19	A61N	2 3/4" STILE METAL	2	ALUMINUM	BONNELL
	A613	4 11/16" STILE METAL	1 OR 3	ALUMINUM	BONNELL
20	220J	COLONIAL GLAZING STOP	4	WOOD	EAGLE WINDOW & DOOR
21	A699	PANEL WEDGE	4	NYLON	LAKE COUNTRY SALES
22	A283	ARLOC BULB WEATHERSTIP	3	PPR	INTEK
23	A01A	SEALANT BUTYL TAPE	AS REQUIRED	BUTYL RUBBER	PTI INC.
24	A08K	GLAZING SHIM	AS REQUIRED	NEOPRENE RUBBER	CLIM-A-TECH
25	A67M	.031 x .625 FOAM TAPE (GLASS STOP TAPE)	4	POLYETHYLENE	ADHESIVE RESEARCH
26	A00E	GLASS SETTING BLOCK, NEOPRENE	AS REQUIRED	NEOPRENE RUBBER	CLIM-A-TECH
27	A00T	#7 X 7/8" FHWS S.S.	6	STAINLESS STEEL	DECO PRODUCTS CO.
28	A49X	PANEL CAP	1	ALUMINUM	BONNELL
29	20DJ	8" BOTTOM RAIL	1	WOOD	PAC. WOOD LAMINATES
30	A64K	8" BOTTOM RAIL COVER	1	ALUMINUM	BONNELL
31	A27B	ANCHOR CLIP	AS REQUIRED	GALVANIZED STEEL	EAGLE WINDOW & DOOR
32	A43D	2 1/2" BRAD .077 DIA	4	GALVANIZED STEEL	ABILITY FASTENERS
33	20A4	WOOD DOWEL	8	WHITE BIRCH	EXCEL DOWEL
34	21HC	OAK OUTSWING SILL TRIM LF	1	WOOD	EAGLE WINDOW & DOOR
35	21HE	OAK CAP FOR O/S SILL LF	1	WOOD	EAGLE WINDOW & DOOR
36	A019	3/4" INSULATED GLASS	1	GLASS	CARDINAL IG
	A32Y	SINGLE PANE GLASS (MONOLITHIC)		GLASS	CARDINAL IG
37	20E2	RAISED PANEL INSERT	2 OR 4	WOOD	SIEMEN WOODWORKS
38	A64L	RAISED PANEL CLADDING	1 OR 2	ALUMINUM	DIE MAKERS
39					
40					
41					
42	H-40	5/8" BETWEEN GLASS MUNTIN	AS REQUIRED	ALUMINUM	ALLMETAL
43	P/PD	1" CONTOUR MUNTIN	AS REQUIRED	ALUMINUM	ALLMETAL
44	220H	1 1/2" INTERIOR COLONIAL MDL BAR	AS REQUIRED	WOOD	EAGLE WINDOW & DOOR
45	H-40	SPACER CHANNEL	AS REQUIRED	ALUMINUM	ALLMETAL
46	A507	1 1/2" EXTERIOR MDL BAR	AS REQUIRED	ALUMINUM	BONNELL
47	A67X	1 1/2" MDL ADHESIVE TAPE (EXTERIOR TAPE)	AS REQUIRED	POLYETHYLENE	ADHESIVE RESEARCH
48	A67L	1 1/2" MDL ADHESIVE TAPE (INTERIOR TAPE)	AS REQUIRED	POLYETHYLENE	ADHESIVE RESEARCH
49	220H	1 1/8" INTERIOR COLONIAL MDL BAR	AS REQUIRED	WOOD	EAGLE WINDOW & DOOR
50	H-40	SPACER CHANNEL	AS REQUIRED	ALUMINUM	ALLMETAL
51	A507	1 1/8" EXTERIOR MDL BAR	AS REQUIRED	ALUMINUM	BONNELL
52	A67W	1 1/8" MDL ADHESIVE TAPE (EXTERIOR TAPE)	AS REQUIRED	POLYETHYLENE	ADHESIVE RESEARCH
53	A67R	1 1/8" MDL ADHESIVE TAPE (INTERIOR TAPE)	AS REQUIRED	POLYETHYLENE	ADHESIVE RESEARCH
54	220H	7/8" INTERIOR COLONIAL MDL BAR	AS REQUIRED	WOOD	EAGLE WINDOW & DOOR
55	H-40	SPACER CHANNEL	AS REQUIRED	ALUMINUM	ALLMETAL
56	A507	7/8" EXTERIOR MDL BAR	AS REQUIRED	ALUMINUM	BONNELL
57	A67T	7/8" MDL ADHESIVE TAPE (EXTERIOR TAPE)	AS REQUIRED	POLYETHYLENE	ADHESIVE RESEARCH
58	A67N	7/8" MDL ADHESIVE TAPE (INTERIOR TAPE)	AS REQUIRED	POLYETHYLENE	ADHESIVE RESEARCH
59	N/A	ADHESIVE TAPE	AS REQUIRED	POLYETHYLENE	CARDINAL IG



Architectural Testing

Test sample complies with these details.
Deviations are noted.

Report# 68741

Date 11/8-9/06 Tech gpk

TITLE: O/S FR DOOR SDLT
UNIT ASSEMBLY

FINISH:

MATL:

DFT: TWN SCALE: 1=1
DCN: 0836 DRWG: 0464

DATE: 6/9/05 C 07

NO | DESCRIPTION | DFT | DOC | DATE

NOTE: 1. (14) #8 X 3 SCREWS INTO BUCK THRU SIDE JAMBS 6" FROM EACH END AND EQUALLY SPACED THEREAFTER.
 2. CENTER NAIL FIN, PLACE NAIL IN FIRST HOLE AND THEN EVERY OTHER THEREAFTER. (39) 2" ROOFING NAILS THROUGH NAIL FIN INTO BUCK.

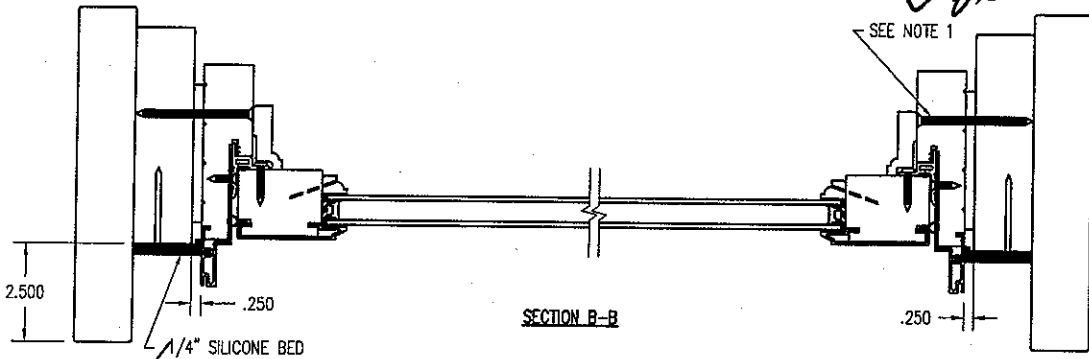

SEE NOTE #2
 2 X 12 BUCK
 2 X 6 BUCK

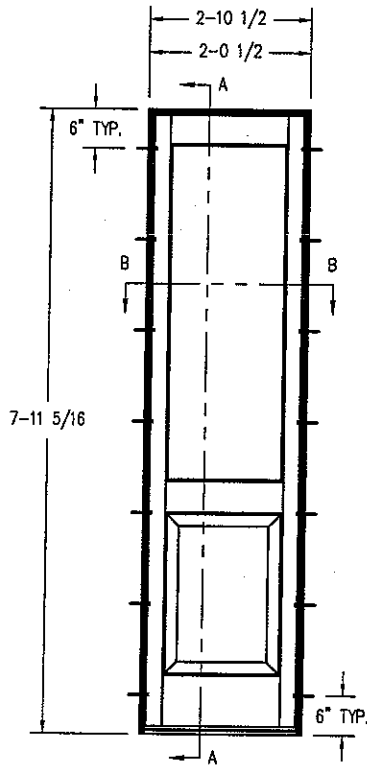
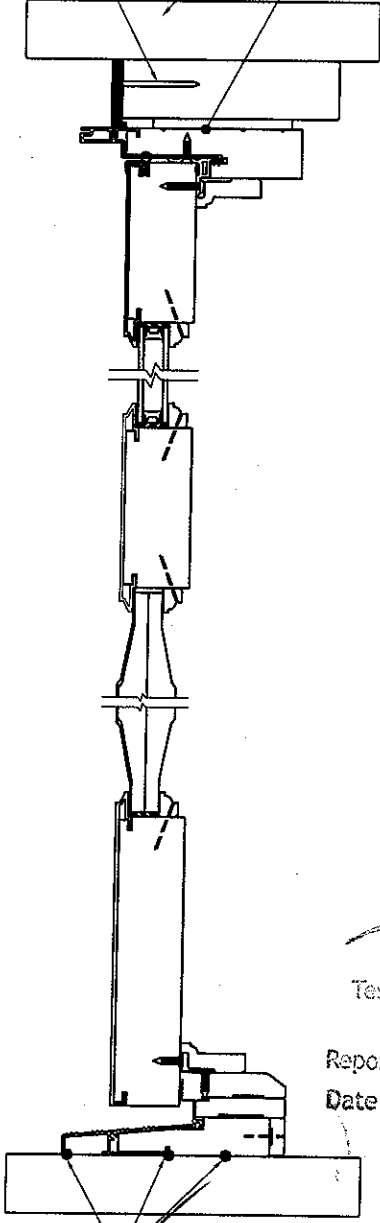

Architectural Testing

Test sample complies with these details.
 Deviations are noted.

Report# 68741
 Date 11/8-9/06 Tech gpk

1/4" BEAD OF SILICONE

SECTION A-A

THIS DRAWING AND ITS CONTENTS ARE THE PROPERTY OF EAGLE WINDOW & DOOR. NO USE OR REPRODUCTION OF THE CONTENTS OF THIS DOCUMENT IS PERMITTED WITHOUT THE EXPRESS WRITTEN PERMISSION OF EAGLE WINDOW & DOOR.	
TITLE: CLAD O/S SDLT INSTALL. DETAIL W/ RAISED PANEL & MID-RAIL	
FINISH:	
MATERIAL:	
DFT: TWN	SCALE: 1=5
DCN: 0836	DRWG: 040A
DATE: 6/20/2005	C 08

NO	DESCRIPTION	DFT	DOC	DATE

- NOTE: 1. UNLESS OTHERWISE SPECIFIED, ALL DIMENSIONS SHOWN ARE IN INCHES AND ALL TOLERANCES ARE TO BE: DEC. ± 0.10 ; FRAC. $\pm 1/64$; ANGLES $\pm 1/2$.
2. NO TELEGRAPHING (VISIBILITY) OF CORE GLUE JOINTS THROUGH ANY EXPOSED VENEER SURFACE IS ALLOWED.
3. ACCEPTABLE MATERIAL FOR THIS PART WHEN USED IN STAIN GRADE FINAL PRODUCT (i.e.; UNFINISHED, CLEAR FINISHED, STAINED, OR STAINED AND CLEAR FINISHED) IS DEFINED ON DRAWING 200G.
- ACCEPTABLE MATERIAL FOR THIS PART WHEN USED IN PAINT GRADE FINAL PRODUCT (i.e.; INTERIOR PRIMED OR INTERIOR PAINTED) INCLUDES ANY OF THE FOLLOWING:
- A. AS DEFINED ON DRAWING 200G.
- B. EDGE GLUED, FINGER-JOINTED, OR EDGE GLUED AND FINGER JOINTED PINE (SUGAR AND/OR PONDEROSA). ALL GLUED JOINTS MUST BE ADHERED USING AN EXTERIOR GRADE TYPE I BOND ADHESIVE. BROWN AND BLUE STAIN PARTS ARE NOT PERMITTED. SINKER STOCK IS NOT PERMITTED. NO KNOTS OR PITCH POCKETS ARE ALLOWED ON EXPOSED SURFACES. LESS THAN OR EQUAL TO 10% OF MATERIAL IN UNEXPOSED AREA MAY HAVE SMALL (LESS THAN 1/4" DIA.), SOLID, TIGHT KNOTS AND SMALL PITCH POCKETS (LESS THAN 1/4" DIA. x 1/2" LENGTH).

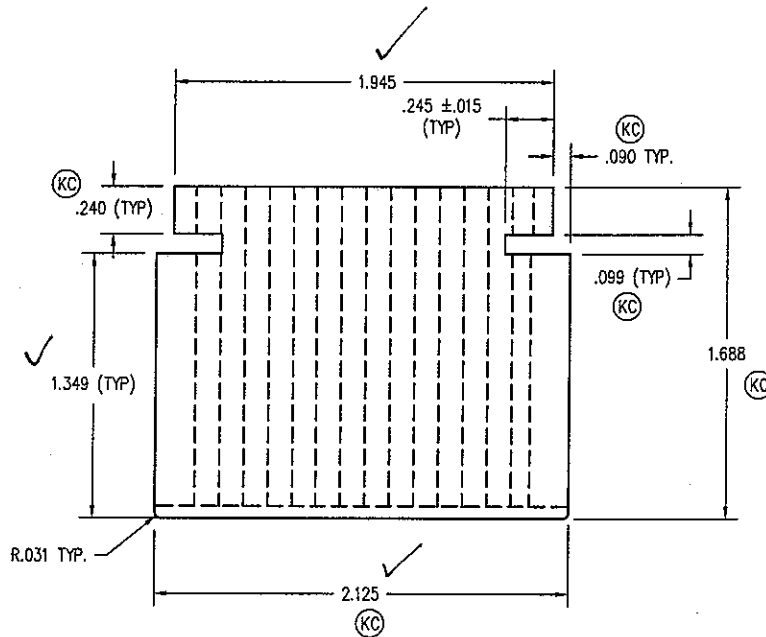

Test sample complies with these details.
Deviations are noted.

Report# 68741
Date 11/8-9/06 Tech JMK



THIS DRAWING AND ITS CONTENTS ARE THE PROPERTY OF EAGLE WINDOW & DOOR. NO USE OR REPRODUCTION OF THE CONTENTS OF THIS DOCUMENT IS PERMITTED WITHOUT THE EXPRESS WRITTEN PERMISSION OF EAGLE WINDOW & DOOR.

TITLE: 2 3/4" STILE / RAIL

FINISH: PRESERVATIVE (SEE #A02J) ALSO (INT. A02F)

MATL: SEE NOTE #3

03	CHANGED PAGE NUMBER	KJS	1015	3/6/06			
02	CHNG'D PROFILE	TWN	PRE	3/22/05	DFT:	TWN	SCALE: 1=1
01	CHNG'D TO MATCH 2006	AWW	PRE	6/30/04	DCN:	0736	DRWG: 2005
NO	DESCRIPTION	DFT	DOC	DATE	DATE:	8/28/2003	C 01 OF 06

- NOTE: 1. UNLESS OTHERWISE SPECIFIED, ALL DIMENSIONS SHOWN ARE IN INCHES AND ALL TOLERANCES ARE TO BE: DEC. ± 0.010 ; FRAC. $\pm 1/64$; ANGLES $\pm 1/2^\circ$.
2. NO TELEGRAPHING (VISIBILITY) OF CORE GLUE JOINTS THROUGH ANY EXPOSED VENEER SURFACE IS ALLOWED.
3. ACCEPTABLE MATERIAL FOR THIS PART WHEN USED IN STAIN GRADE FINAL PRODUCT (i.e.; UNFINISHED, CLEAR FINISHED, STAINED, OR STAINED AND CLEAR FINISHED) IS DEFINED ON DRAWING 20CG.
- ACCEPTABLE MATERIAL FOR THIS PART WHEN USED IN PAINT GRADE FINAL PRODUCT (i.e.; INTERIOR PRIMED OR INTERIOR PAINTED) INCLUDES ANY OF THE FOLLOWING:
- A. AS DEFINED ON DRAWING 20CG.
- B. EDGE GLUED, FINGER-JOINTED, OR EDGE GLUED AND FINGER JOINTED PINE (SUGAR AND/OR PONDEROSA). ALL GLUED JOINTS MUST BE ADHERED USING AN EXTERIOR GRADE TYPE I BOND ADHESIVE. BROWN AND BLUE STAIN PARTS ARE NOT PERMITTED. SINKER STOCK IS NOT PERMITTED. NO KNOTS OR PITCH POCKETS ARE ALLOWED ON EXPOSED SURFACES. LESS THAN OR EQUAL TO 10% OF MATERIAL IN UNEXPOSED AREA MAY HAVE SMALL (LESS THAN $1/4"$ DIA.), SOLID, TIGHT KNOTS AND SMALL PITCH POCKETS (LESS THAN $1/4"$ DIA. x $1/2"$ LENGTH).

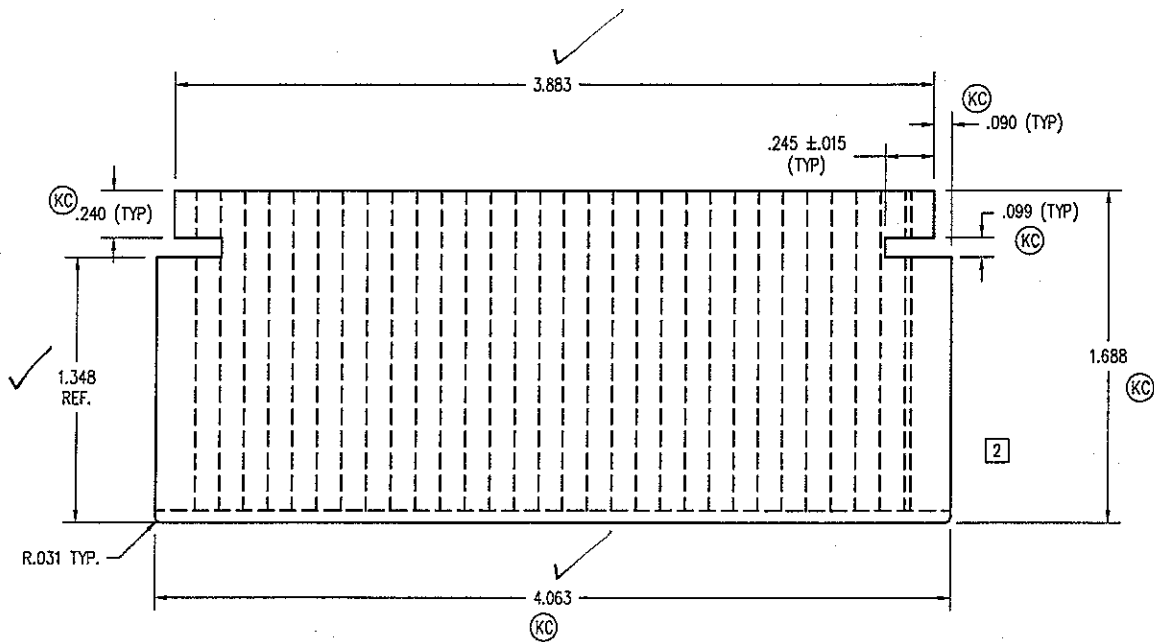

Architectural Testing

Test sample complies with these details.
Deviations are noted.

Report# 68741
Date 11/8-9/06 Tech SJK



THIS DRAWING AND ITS CONTENTS ARE THE PROPERTY OF EAGLE WINDOW & DOOR. NO USE OR REPRODUCTION OF THE CONTENTS OF THIS DOCUMENT IS PERMITTED WITHOUT THE EXPRESS WRITTEN PERMISSION OF EAGLE WINDOW & DOOR.

TITLE: 4 11/16" STILE / RAIL

FINISH: PRESERVATIVE (SEE #A02J) ALSO (INT. A02F) SEE NOTE #3

NO	DESCRIPTION	DFT	DOC	DATE	DATE	DATE	SCALE
04	CHNG'D PROFILE	TWN	PRE	3/22/05	MATL:		
03	.104 (TYP) READ .086	AWW	PRE	10/18/04			
02	REMY'D ANGLE FROM GLASS SHELF	AWW	PRE	10/3/04	DFT:	TWN	SCALE: 1=1
01	CHNG'D TO MATCH 20A1	AWW	PRE	6/28/04	DCN:	0736	DRWG: 2006
					DATE:	8/28/2003	C 01 OF 06

- NOTE: 1. UNLESS OTHERWISE SPECIFIED, ALL DIMENSIONS SHOWN ARE IN INCHES AND ALL TOLERANCES ARE TO BE: DEC. ± 0.010 ; FRAC. $\pm 1/64$; ANGLES $\pm 1/2^\circ$.
2. NO TELEGRAPHING (VISIBILITY) OF CORE GLUE JOINTS THROUGH ANY EXPOSED VENEER SURFACE IS ALLOWED.
3. ACCEPTABLE MATERIAL FOR THIS PART WHEN USED IN STAIN GRADE FINAL PRODUCT (i.e.; UNFINISHED, CLEAR FINISHED, STAINED, OR STAINED AND CLEAR FINISHED) IS DEFINED ON DRAWING 200R.
- ACCEPTABLE MATERIAL FOR THIS PART WHEN USED IN PAINT GRADE FINAL PRODUCT (i.e.; INTERIOR PRIMED OR INTERIOR PAINTED) INCLUDES ANY OF THE FOLLOWING:
- A. AS DEFINED ON DRAWING 200R.
- B. EDGE GLUED, FINGER-JOINTED, OR EDGE GLUED AND FINGER JOINTED PINE (SUGAR AND/OR PONDEROSA). ALL GLUED JOINTS MUST BE ADHERED USING AN EXTERIOR GRADE TYPE I BOND ADHESIVE. BROWN AND BLUE STAIN PARTS ARE NOT PERMITTED. SINKER STOCK IS NOT PERMITTED. NO KNOTS OR PITCH POCKETS ARE ALLOWED ON EXPOSED SURFACES. LESS THAN OR EQUAL TO 10% OF MATERIAL IN UNEXPOSED AREA MAY HAVE SMALL (LESS THAN $1/4"$ DIA.), SOLID, TIGHT KNOTS AND SMALL PITCH POCKETS (LESS THAN $1/4"$ DIA. x $1/2"$ LENGTH).

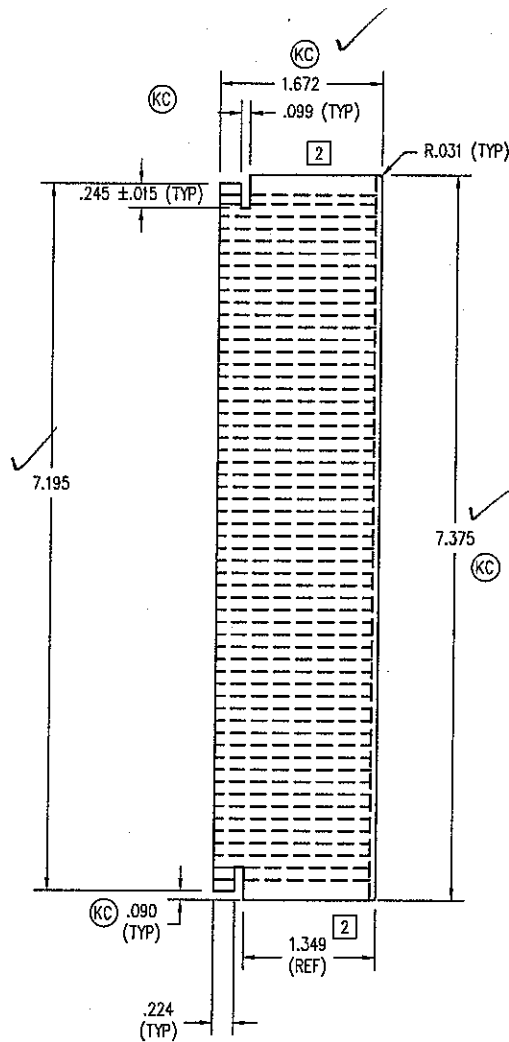

Architectural Testing

Test sample complies with these details.
Deviations are noted.

Report# 68741

Date 11/8-7/06

Tech JK

THIS DRAWING AND ITS CONTENTS ARE THE PROPERTY OF EAGLE WINDOW & DOOR. NO USE OR REPRODUCTION OF THE CONTENTS OF THIS DOCUMENT IS PERMITTED WITHOUT THE EXPRESS WRITTEN PERMISSION OF EAGLE WINDOW & DOOR.

TITLE: **8" BOTTOM RAIL**

FINISH: PRESERVATIVE (SEE A02J)
ALSO (INT. A02F)

04	CHNG'D PROFILE	TWN	PRE	3/22/05	MATL:	SEE NOTE #3
03	.073 WAS .056	AWW	PRE	10/18/04		
02	.015 WAS .094, RMYD ANGLE	AWW	PRE	10/7/04	DFT:	TWN SCALE: 1=2
01	CHNG'D TO MATCH 2009	AWW	PRE	6/30/2004	DCN:	0736 DRWG: 20DJ
NO	DESCRIPTION	DFT	DOC	DATE	DATE:	3/31/2004 C 01 OF 02

Note:1 UNLESS OTHERWISE SPECIFIED, ALL DIMENSIONS ARE SHOWN ARE IN INCHES AND ALL TOLERANCES ARE TO BE: DEC. +/- .005, FRACTION +/- 1/64, ANGLES +/- 1/2.

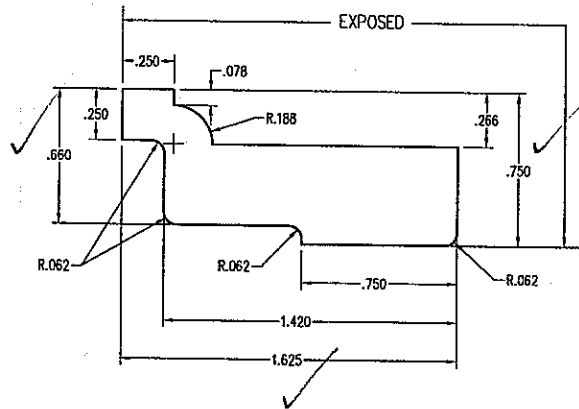

Architectural Testing

Test sample complies with these details.
Deviations are noted.

Report# 68741

Date 11/8-9/06 Tech APK

NO	Description of Change	Drafter	DCN#	Date
1	SOLT/TRANSOM PANEL STOP			
Finish:		Material EAGLE'S STD. WOOD OFFERINGS		
Scale: 2=1	Date: 2/25/2006	THIS DRAWING AND ITS CONTENTS ARE THE PROPERTY OF EAGLE WINDOW & DOOR. NO USE OR REPRODUCTION OF THE CONTENTS OF THIS DOCUMENT IS PERMITTED WITHOUT THE EXPRESS WRITTEN PERMISSION OF EAGLE WINDOW & DOOR.		REVISION: 20EJ
Drafter: tries	DCN# 0638	0	01 of 03	

- NOTE: 1. UNLESS OTHERWISE SPECIFIED, ALL DIMENSIONS SHOWN ARE IN INCHES AND ALL TOLERANCES ARE TO BE: DEC. ± 0.005 ; FRACTIONAL $\pm 1/64$; ANGLES $\pm 1/2^\circ$.
 2. CLAD, L = FRAME WIDTH - 2 1/2"
 WOOD, L = FRAME WIDTH - 2 3/4"

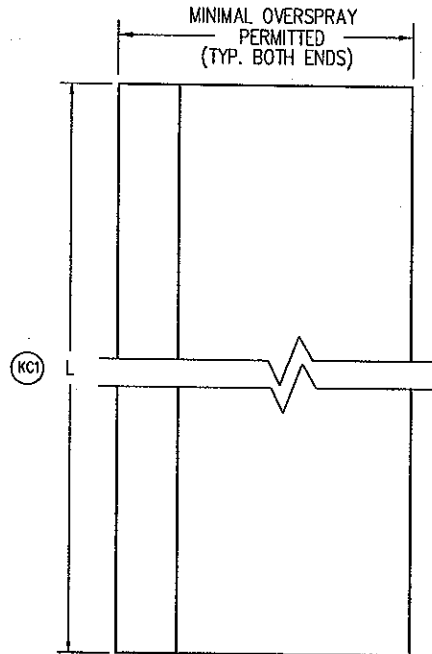

CLAD	
O.S. SIDELITE	
FRAME WIDTH	L
24 1/2	22
30 1/2	28
32 1/2	30
36 1/2	34

1

WOOD	
O.S. SIDELITE	
FRAME WIDTH	L
24 1/2	21 3/4
30 1/2	27 3/4
32 1/2	29 3/4
36 1/2	33 3/4

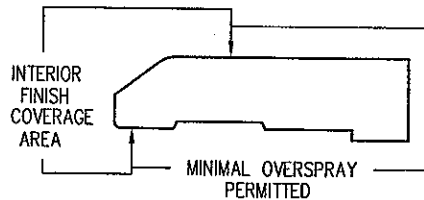

THIS DRAWING AND ITS CONTENTS ARE THE PROPERTY OF EAGLE WINDOW & DOOR. NO USE OR REPRODUCTION OF THE CONTENTS OF THIS DOCUMENT IS PERMITTED WITHOUT THE EXPRESS WRITTEN PERMISSION OF EAGLE WINDOW & DOOR.

TITLE: OUTSWING SIDELITE SILL STOP

FINISH: PRESERVATIVE

MATL: OAK

Architectural Testing

Test sample complies with these details.
 Deviations are noted.

Report# 68741

Date 11/8-9/06 Tech JDK

02	ADDED "PRESERVATIVE"	JH	0911	9/14/04	DFT:	MJP	SCALE:	1=1
01	CHANGED CLAD O/S DOOR WIDTH	TWN	0632	11/29/01	DCN:	0243	DRWC:	21H4
NO	DESCRIPTION	DFT	DOC	DATE	DATE:	5/15/1997	A	02

NOTE: 1. UNLESS OTHERWISE SPECIFIED, ALL DIMENSIONS SHOWN ARE IN INCHES AND ALL TOLERANCES ARE TO BE: DEC. ± 0.005 ; FRAC. $\pm 1/64$; ANGLES $\pm 1/2^\circ$.

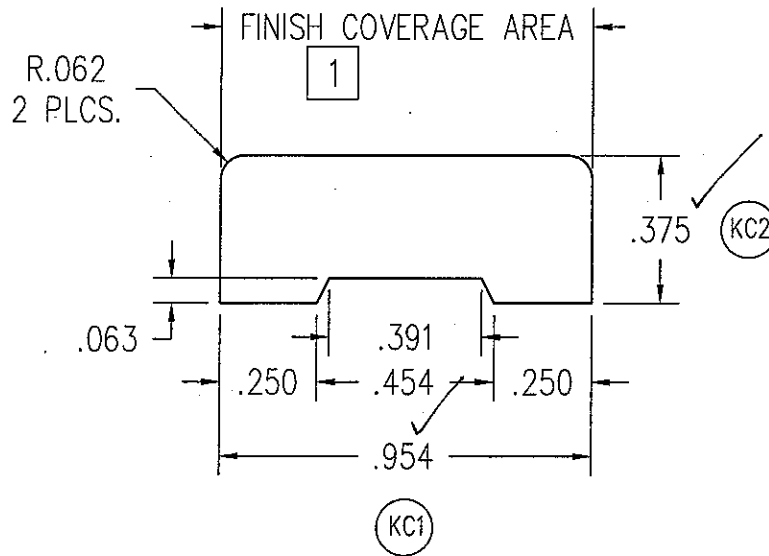

Test sample complies with these details.
Deviations are noted.

Report# 68741
Date 11/8-9/06 Tech OPK

THIS DRAWING AND ITS CONTENTS ARE THE PROPERTY OF EAGLE WINDOW & DOOR. NO USE OR REPRODUCTION OF THE CONTENTS OF THIS DOCUMENT IS PERMITTED WITHOUT THE EXPRESS WRITTEN PERMISSION OF EAGLE WINDOW & DOOR.

TITLE: OUTSWING SILL TRIM

FINISH: PRESERVATIVE

MATL: OAK

DFT: MJP SCALE: 2=1

DCN: 0243 DRWG: 21HC

DATE: 1/2/1997 A 01 OF 02

NO	DESCRIPTION	DFT	DOC	DATE
01	ADDED FINISH COVERAGE AREA	JH	0911	09/15/04

NOTE: 1. UNLESS OTHERWISE SPECIFIED, ALL DIMENSIONS SHOWN ARE IN INCHES AND ALL TOLERANCES ARE TO BE: DEC. ± 0.005 ; FRAC. $\pm 1/64$; ANGLES $\pm 1/2^\circ$.

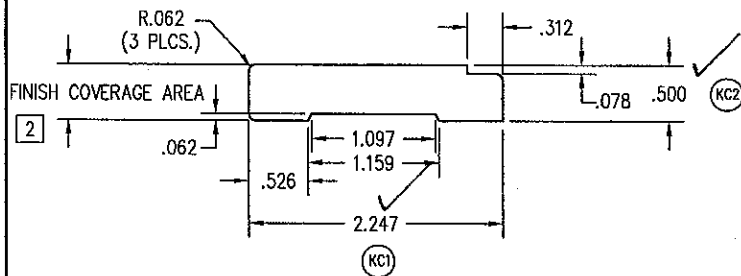

Architectural Testing

Test sample complies with these details.
Deviations are noted.

Report# 68741

Date 11/2-9/06 Tech SPK

THIS DRAWING AND ITS CONTENTS ARE THE PROPERTY OF EAGLE WINDOW & DOOR. NO USE OR REPRODUCTION OF THE CONTENTS OF THIS DOCUMENT IS PERMITTED WITHOUT THE EXPRESS WRITTEN PERMISSION OF EAGLE WINDOW & DOOR.

TITLE: OAK CAP FOR OUTSWING SILL

FINISH: PRESERVATIVE

MATL: OAK

02	ADDED "COVERAGE AREA"	JH	0911	9/15/04	DFT:	TSB	SCALE:	1=1
01	REMOVED .015 STEP	MJP	0243	7/28/97	DCN:	0243	DRWG:	21HE
NO	DESCRIPTION	DFT	DOC	DATE	DATE:	1/2/1997	A	01 OF 02

Note: 1. UNLESS OTHERWISE SPECIFIED, ALL DIMENSIONS ARE SHOWN ARE IN INCHES AND ALL TOLERANCES ARE TO BE: DEC.+/- .005, FRACTION +/- 1/64, ANGLES +/- 1/2.
 2. THIS VENEER TO HAVE A MINIMUM THICKNESS OF .080.

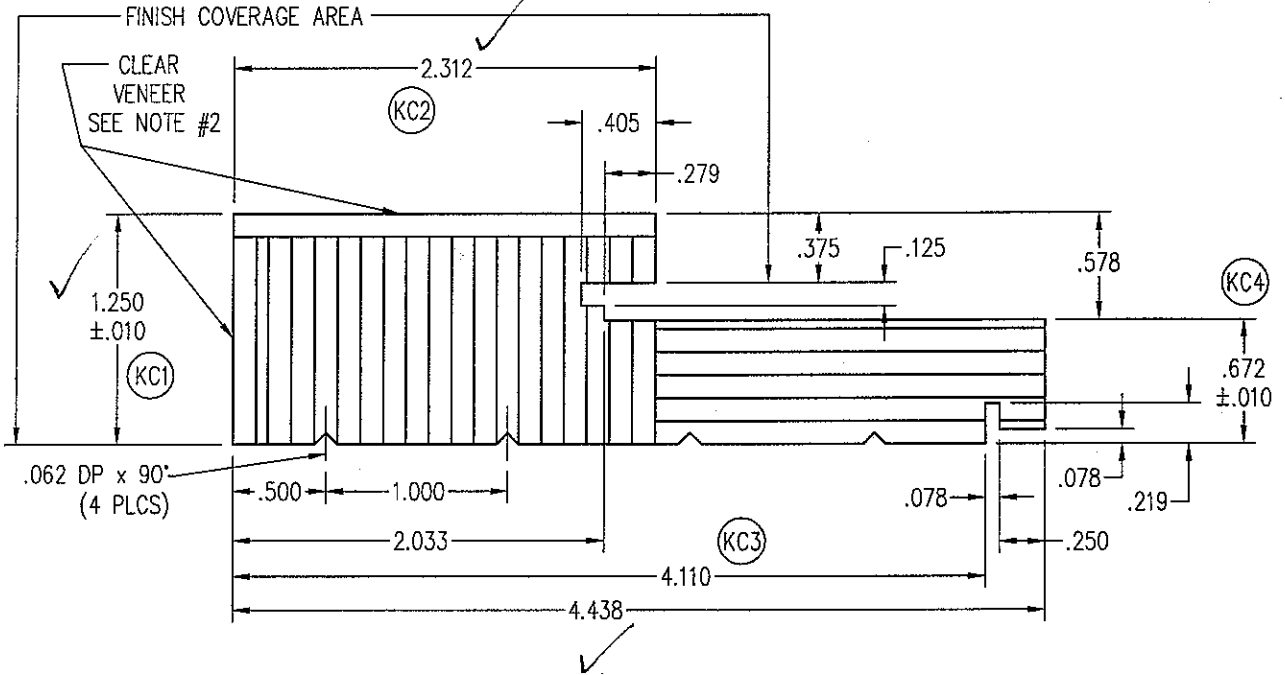

Test sample complies with these details.
 Deviations are noted.

Report# 68741
 Date 11/8-9/06 Tech APK

NO	Description of Change	Drafter	DCN#	Date
05	CHANGED WOOD MATERIAL TO LVL AND REMOVED EXTENSION JAMB NOTCH OPTION	TWN	0836A	2/8/2006
04	ADDED FINISH COVERAGE AREA, AND CHANGED TITLE BLOCK	JH	0924	11/4/2004
03	ADDED NOTCH	RDA	0260	5/2/1997
02	REVISED PROFILE	MJP	0199	4/13/1995
01	ADDED NOTES 2 & 3	BRL	0189	2/3/1995

Title: JAMB		Finish:	Material: SEE NOTES #3
Scale: 1"=1"	Date: 4/7/1993	THIS DRAWING AND ITS CONTENTS ARE THE PROPERTY OF EAGLE WINDOW & DOOR. NO USE OR REPRODUCTION OF THE CONTENTS OF THIS DOCUMENT IS PERMITTED WITHOUT THE EXPRESS WRITTEN PERMISSION OF EAGLE WINDOW & DOOR.	
Drafter: JMH	DCN#: 0037		

NOTE: 1. UNLESS OTHERWISE SPECIFIED, ALL DIMENSIONS SHOWN ARE IN INCHES AND ALL TOLERANCES ARE TO BE: DEC. ±.005; FRAC. ±1/64; ANGLES ±1/2°.

PRODUCT	GLASS	A
(PRE '96 & NG) CLAD CASEMENT & AWNING	5/8"	.469
(PRE '96 & NG) CLAD CASEMENT PICTURE	3/4"	.469
CLAD PIANO HINGE CASEMENT	5/8"	.469
CLAD PIANO HINGE CASEMENT (3056 & ABOVE)	3/4"	.469
CLAD RADIUS CASEMENT	5/8" & 3/4"	.469
(PRE '96 & NG) CLAD DOUBLE / SINGLE HUNG	5/8"	.469
(PRE '96 & NG) CLAD DOUBLE HUNG PICTURE	5/8"	.469
CLAD DOUBLE HUNG TRANSOM	5/8"	.469
CLAD DOUBLE HUNG REPLACEMENT SASH	5/8"	.469
ALL CLAD (NON-RADIUS) AUXILIARY (0-15 SQ. FT.)	3/4"	.469
ALL CLAD (NON-RADIUS) AUXILIARY (15+ SQ. FT.)	1"	.469
CLAD SLIDING WINDOW	5/8"	.469
CLAD INSWING / OUTSWING FRENCH DOOR	3/4"	.469
CLAD FRENCH DOOR TRANSOM	3/4"	.469
CLAD PATIO / FRENCH SLIDING DOOR	3/4"	.469
(PRE '98) WOOD CASEMENT & AWNING	3/4"	.680
(PRE '98) WOOD CASEMENT PICTURE	3/4"	.680
(NG) WOOD CASEMENT & AWNING	5/8"	.469
(NG) WOOD CASEMENT PICTURE	5/8" & 3/4"	.469
WOOD PIANO HINGE CASEMENT	5/8"	.469
WOOD PIANO HINGE CASEMENT (3056 & ABOVE)	3/4"	.469
(PRE '96 & NG) WOOD DOUBLE / SINGLE HUNG	5/8"	.469
(PRE '96 & NG) WOOD DOUBLE HUNG PICTURE	5/8"	.469
WOOD SLIDING WINDOW	5/8"	.469
WOOD DOUBLE HUNG TRANSOM	5/8"	.469
WOOD DOUBLE HUNG REPLACEMENT SASH	5/8"	.469
WOOD (NON-RADIUS) AUXILIARY (0-15 SQ. FT.)	3/4"	.469
WOOD (NON-RADIUS) AUXILIARY (15+ SQ. FT.)	1"	.469
WOOD INSWING / OUTSWING FRENCH DOOR	3/4"	.469
WOOD FRENCH DOOR TRANSOM	3/4"	.469
WOOD PATIO / FRENCH SLIDING DOOR	3/4"	.469
CLAD & WOOD PATIO/FR. SLIDING DOOR (BLIND GLASS)	1"	.406
ALL CLAD AND WOOD WINDOWS AND DOORS EXCEPT AUXILIARY UNITS WHICH ALWAYS USES .469	SINGLE GLAZED H. MSTR MONO	.680

PANEL STOPS	
PRODUCT	A
WOOD OUTSWING SIDELITE	.469
WOOD OUTSWING TRANSOM	.469
WOOD INSWING SIDELITE	.469
WOOD INSWING TRANSOM	.469



Architectural Testing

Test sample complies with these details. Deviations are noted.

Report# 68741

Date 11/8-9/06 Tech *JPK*

.062 x .062 CHAMFER

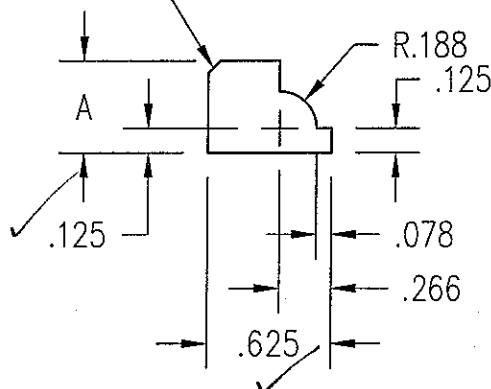

THIS DRAWING AND ITS CONTENTS ARE THE PROPERTY OF EAGLE WINDOW & DOOR. NO USE OR REPRODUCTION OF THE CONTENTS OF THIS DOCUMENT IS PERMITTED WITHOUT THE EXPRESS WRITTEN PERMISSION OF EAGLE WINDOW & DOOR.

TITLE: COLONIAL GLAZING STOP

FINISH:

MATL:

EAGLE STD WOOD OFFERINGS

03 ADDED SIZE FOR IMPACT GLAZING TWN 0972 9/1/05

02 CHG'D CLAD PANEL STOP "A" DIM JH 0794 6/30/05

01 ADDED KYLER BLIND SIZE TWN 0910 4/19/05

NO DESCRIPTION DFT DOC DATE

DFT: JMH SCALE: 1=1

DCN: 0650 DRWG: 220J

DATE: 5/29/2002 A 01 OF 03

NOTE 1. UNLESS OTHERWISE SPECIFIED, ALL DIMENSIONS SHOWN ARE IN INCHES AND ALL DIMENSIONS ARE TO BE DEC. 2. UNLESS OTHERWISE SPECIFIED, WALL THICKNESS IS .002.
 2. UNLESS OTHERWISE SPECIFIED, WALL THICKNESS IS .002.
 3. UNLESS OTHERWISE SPECIFIED, SHOW ALL CORNERS .015 RADIUS.

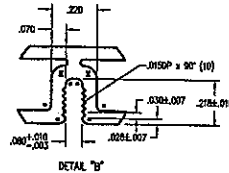
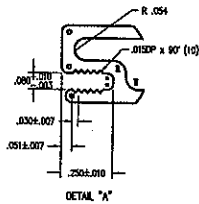
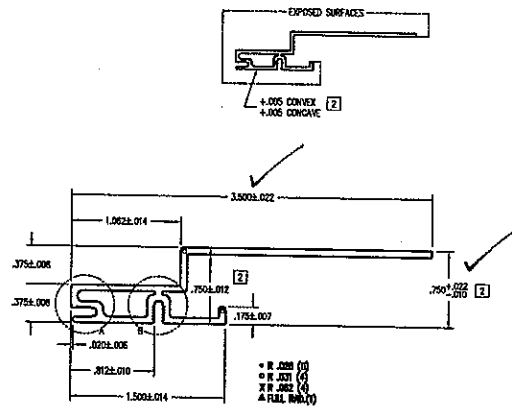

 Architectural Testing

Test sample complies with these details.
 Deviations are noted.

Report# 68741

Date 11/8-9/06 Tech JK

PROJECT NO.	68741
DATE	11/8-9/06
BY	JK
CHECKED BY	
APPROVED BY	
SCALE	AS SHOWN
TITLE	Q/S JAW COLUMN
FORM	Q/S JAW COLUMN
MATERIAL	6061 T-6 ALUMINUM

- NOTE: 1. UNLESS OTHERWISE SPECIFIED, ALL DIMENSIONS SHOWN ARE IN INCHES AND ALL TOLERANCES ARE TO BE: DEC. ± 0.010 ; FRAC. $\pm 1/64$; ANGLES $\pm 1/2^\circ$.
 2. WALL THICKNESS .040 UNLESS OTHERWISE SPECIFIED.

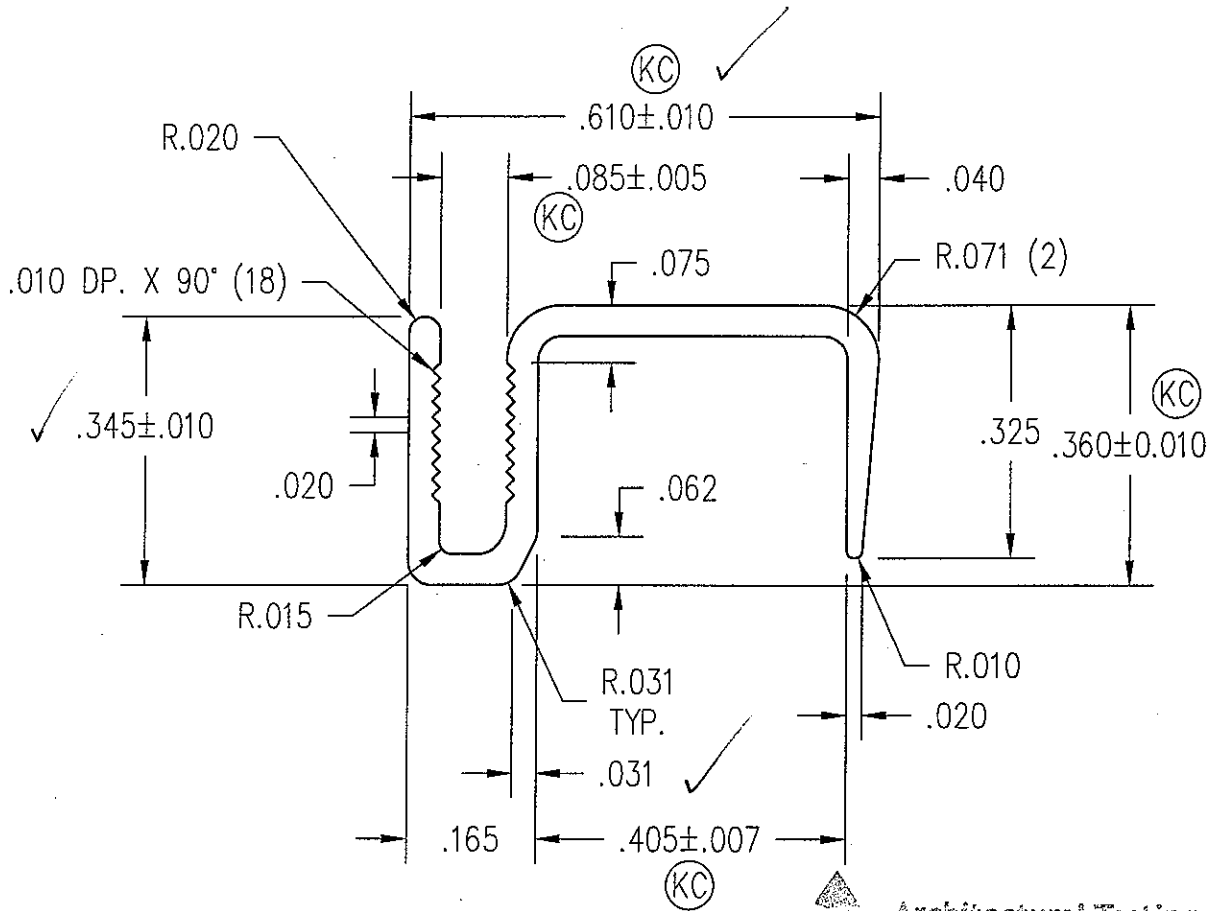

 Architectural Testing

Test sample complies with these details.
 Deviations are noted.

Report# 68741
 Date 11/8-9/06 Tech apk

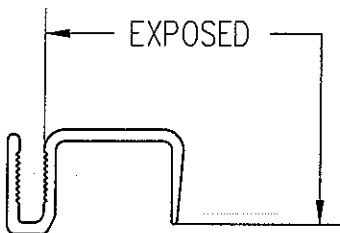

THIS DRAWING AND ITS CONTENTS ARE THE PROPERTY OF EAGLE WINDOW & DOOR. NO USE OR REPRODUCTION OF THE CONTENTS OF THIS DOCUMENT IS PERMITTED WITHOUT THE EXPRESS WRITTEN PERMISSION OF EAGLE WINDOW & DOOR.

TITLE: FRENCH DOOR PANEL CAP

FINISH: EAGLE'S STD. COLORS

MATL: 6030 T-6 ALUMINUM

DFT: TWN SCALE: 4=1

DCN: 0838 DRWG: A49X

DATE: 9/7/2001 A 01 OF 02

NO	DESCRIPTION	DFT	DOC	DATE

- NOTE: 1. UNLESS OTHERWISE SPECIFIED, ALL DIMENSIONS SHOWN ARE IN INCHES AND ALL TOLERANCES ARE TO BE: DEC. ± 0.005 ; FRAC. $\pm 1/64$; ANGLES $\pm 1/2^\circ$.
 2. WALL THICKNESS TO BE .062 UNLESS OTHERWISE SPECIFIED.
 3. ALL CORNERS TO BE .015 UNLESS OTHERWISE SPECIFIED.
 4. AREA = .270 SQ. IN.

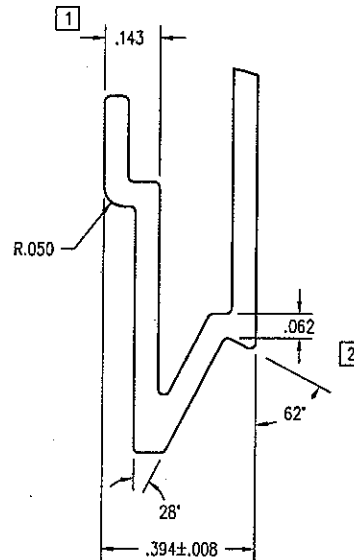
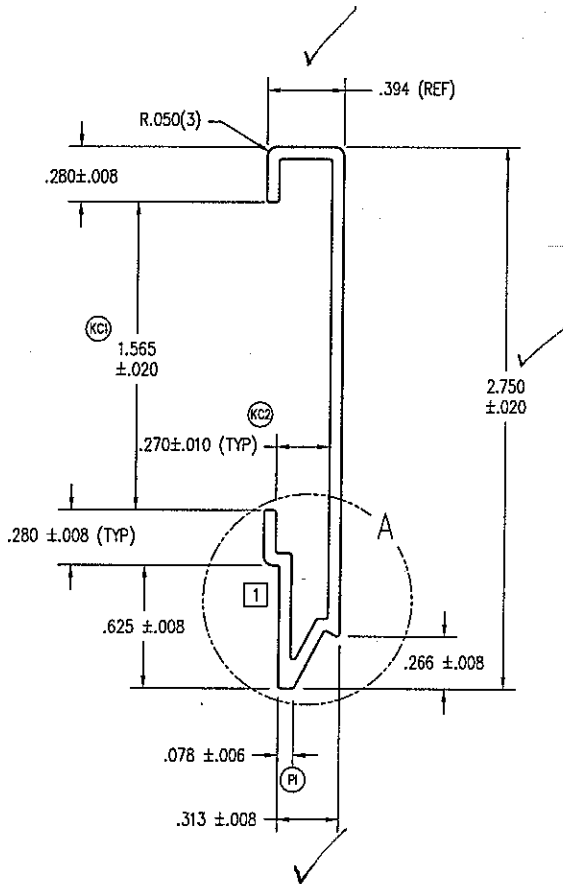
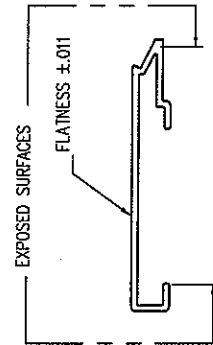

DETAIL A
SCALE: 2 = 1



Architectural Testing

Test sample complies with these details.
Deviations are noted.

Report# 68741
 Date 11/8-9/06 Tech gpk

THIS DRAWING AND ITS CONTENTS ARE THE PROPERTY OF EAGLE WINDOW & DOOR. NO USE OR REPRODUCTION OF THE CONTENTS OF THIS DOCUMENT IS PERMITTED WITHOUT THE EXPRESS WRITTEN PERMISSION OF EAGLE WINDOW & DOOR.
 TITLE: 2 3/4" PANEL CLADDING INTERLOCK FIT
 FINISH: EAGLE'S STD. COLORS
 MATE: 6063 T-6 ALUMINUM

02	REVISED NOSING PROFILE	TWN	PRE	5/06/05	DFT:	AWW	SCALE: 1=1
01	IRMYD SEMI-HOLLOW LEG	AWW	PRE	8/20/03	DCN:	0736	DRWS: A61N
NO	DESCRIPTION	DFT	DOC	DATE	DATE:	8/15/2003	C 01 OF 03

- NOTE: 1. UNLESS OTHERWISE SPECIFIED, ALL DIMENSIONS SHOWN ARE IN INCHES AND ALL TOLERANCES ARE TO BE: DEC. ± 0.005 ; FRAC. $\pm 1/64$; ANGLES $\pm 1/2^\circ$.
 2. WALL THICKNESS TO BE $.082$ UNLESS OTHERWISE SPECIFIED.
 3. ALL CORNERS TO BE $.015$ UNLESS OTHERWISE SPECIFIED.
 4. AREA = $.743$ SQ. IN.

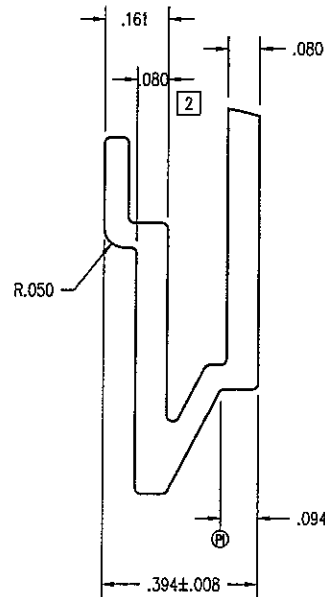
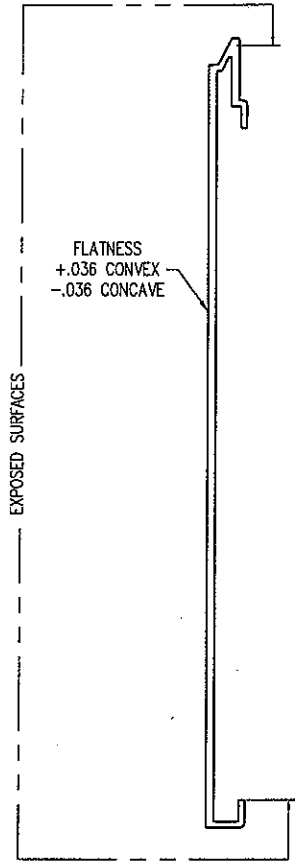
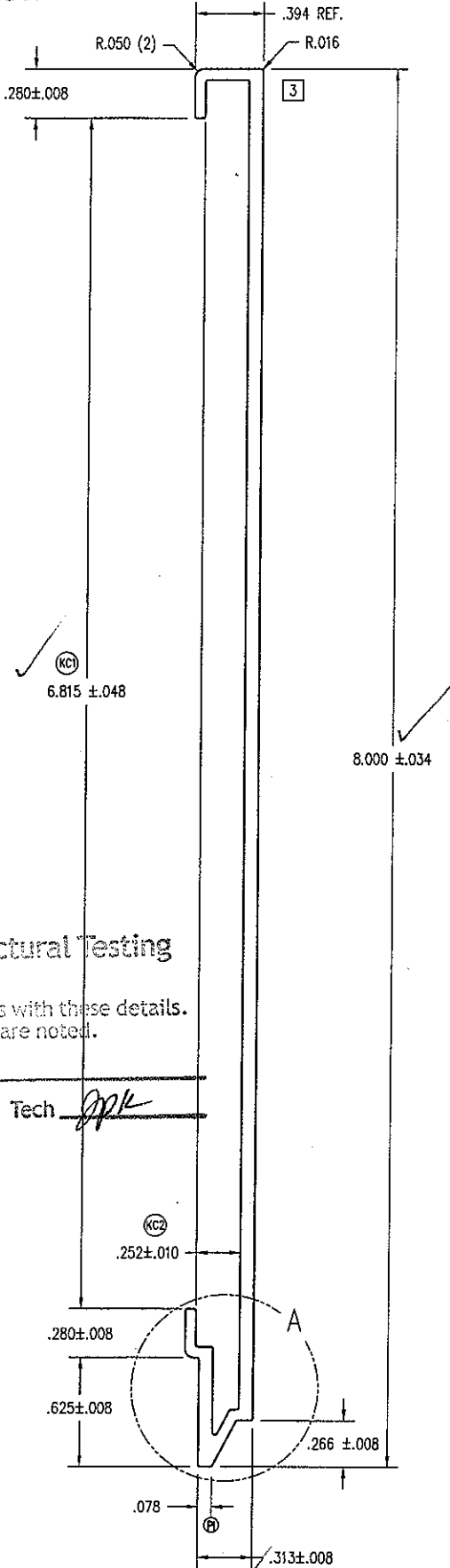

DETAIL A
SCALE: 2 = 1

Architectural Testing
 Test sample complies with these details.
 Deviations are noted.

Report# 68741
 Date 11/8-9/06 Tech APK

THIS DRAWING AND ITS CONTENTS ARE THE PROPERTY OF EAGLE WINDOW & DOOR. NO USE OR REPRODUCTION OF THE CONTENTS OF THIS DOCUMENT IS PERMITTED WITHOUT THE EXPRESS WRITTEN PERMISSION OF EAGLE WINDOW & DOOR.
 TITLE: 8" PANEL CLADDING INTERLOCK FIT
 FINISH: EAGLE'S STD. COLORS
 MATL: 6063 T-6 ALUMINUM

03	MADE CORNER RADIUS .015	AWW	PRE	10/7/04			
02	MADE WALL .080, NOT .062	AWW	PRE	6/28/04	DFT:	AWW	SCALE: 1=1
01	REMOVED "BUMPS"	TWN	PRE	5/5/04	DCN:	0736	DRWG: A64K
NO	DESCRIPTION	DFT	DOC	DATE	DATE: 7/14/2003	C	01 OF 02

- NOTE: 1. UNLESS OTHERWISE SPECIFIED, ALL DIMENSIONS SHOWN ARE IN INCHES AND ALL TOLERANCES ARE TO BE: DEC. ± 0.010 ; FRAC. $\pm 1/64$; ANGLES $\pm 1/2^\circ$.
 2. UNLESS OTHERWISE SPECIFIED ALL RADII .010 .

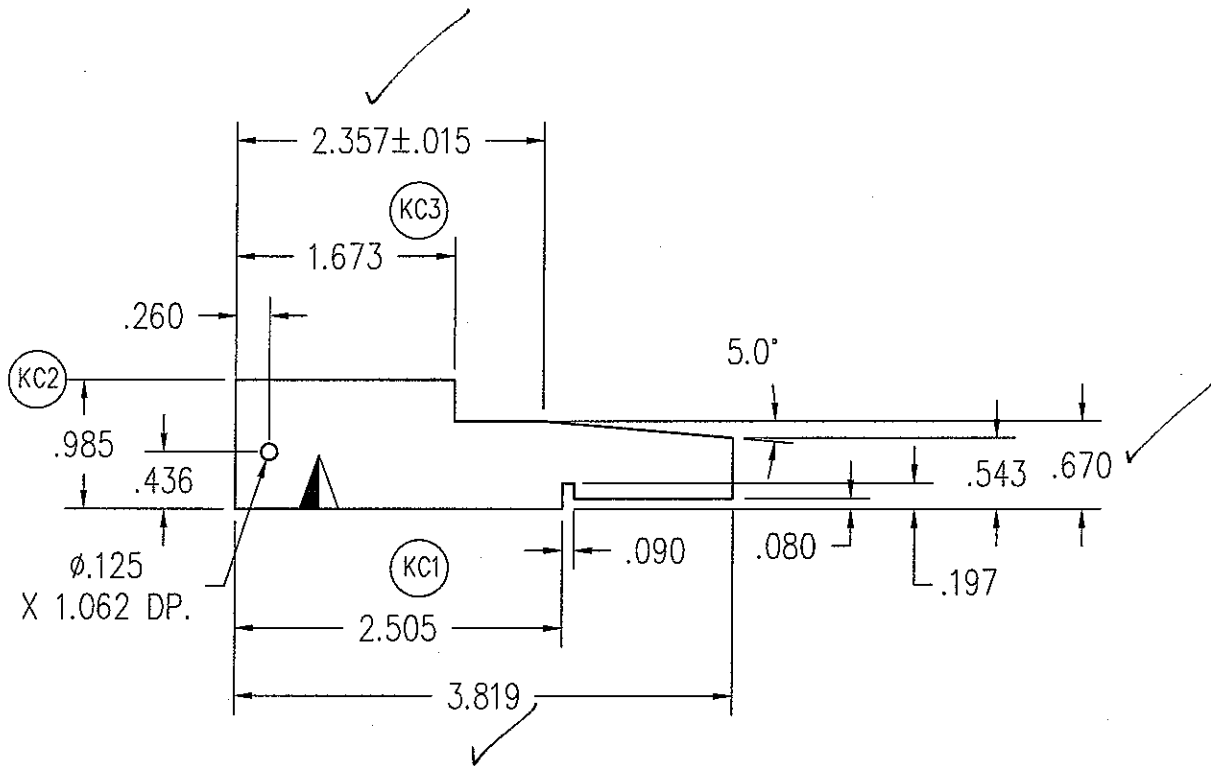

Architectural Testing

Test sample complies with these details.
 Deviations are noted.

Report# 68741

Date 11/8-9/06 Tech gpk

THIS DRAWING AND ITS CONTENTS ARE THE PROPERTY OF EAGLE WINDOW & DOOR. NO USE OR REPRODUCTION OF THE CONTENTS OF THIS DOCUMENT IS PERMITTED WITHOUT THE EXPRESS WRITTEN PERMISSION OF EAGLE WINDOW & DOOR.

TITLE: OUTSWING SUBSILL

FINISH:

MATL: SMART DECK

DFT: tnies

SCALE: 1=1 1/2

DCN: 0879

DRWG: A476

NO DESCRIPTION

DFT

DOC

DATE

DATE: 3/8/2005

A

01 OF 02

- NOTE: 1. UNLESS OTHERWISE SPECIFIED, ALL DIMENSIONS SHOWN ARE IN INCHES AND ALL TOLERANCES ARE TO BE: DEC. $\pm .005$; FRAC. $\pm 1/64$; ANGLES $\pm 1/2^\circ$.
 2. UNLESS OTHERWISE SPECIFIED WALL THICKNESS TO BE .062.
 3. ALL RADII NOT DIMENSIONED TO BE .010
 4. AREA = 0.4707 SQ. IN.
 5. DARK BRONZE ANODOZED PART # 80403, MILL PART # M7298.

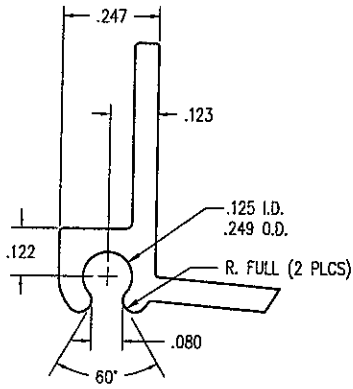

DETAIL A
2 X

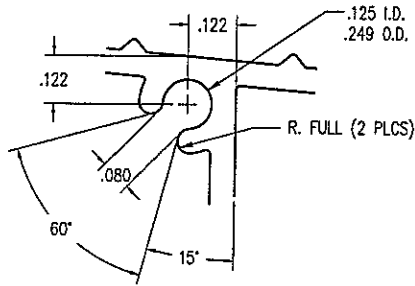

DETAIL B
2 X

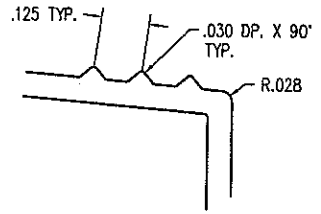

DETAIL C
2 X

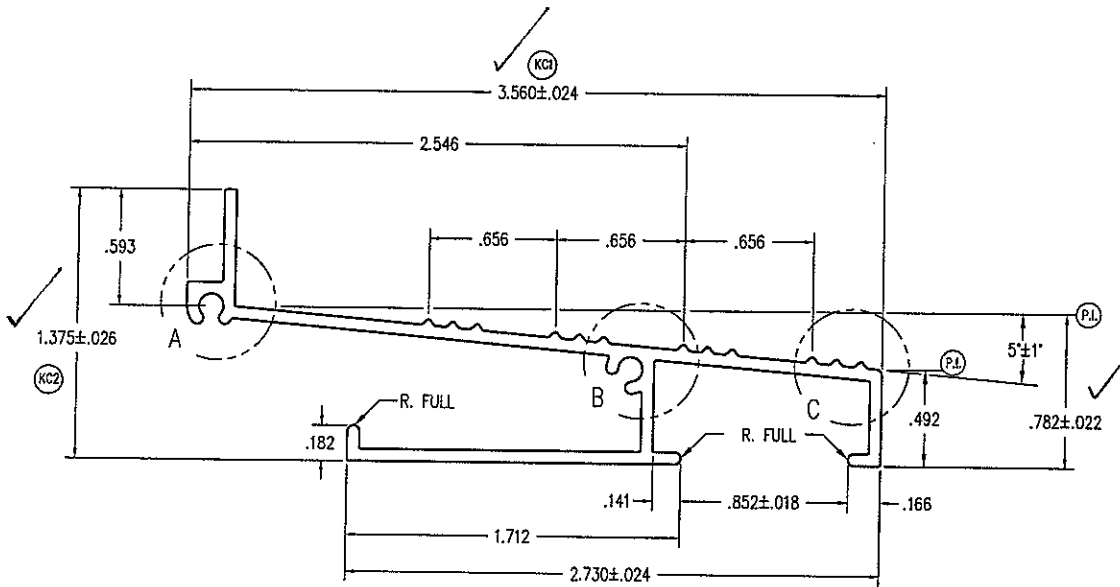

Architectural Testing

Test sample complies with these details.
Deviations are noted.

Report# 68741

Date 11/8-9/06

Tech [Signature]

THIS DRAWING AND ITS CONTENTS ARE THE PROPERTY OF EAGLE WINDOW & DOOR. NO USE OR REPRODUCTION OF THE CONTENTS OF THIS DOCUMENT IS PERMITTED WITHOUT THE EXPRESS WRITTEN PERMISSION OF EAGLE WINDOW & DOOR.	
TITLE: OUTSWING SILL EXTRUSION	
FINISH: MILL OR DARK BRONZE ANODOZED	
MATL: ALUMINUM	
DFT: tnies	SCALE: 1=1
DCN: 0836	DRWG: A477
DATE: 2/23/2005	C 01 OF 03

NO	DESCRIPTION	DFT	DOC	DATE

- NOTE: 1. UNLESS OTHERWISE SPECIFIED, ALL DIMENSIONS SHOWN ARE IN INCHES AND ALL TOLERANCES ARE TO BE: DEC. ± 0.005 ; FRAC. $\pm 1/64$; ANGLES $\pm 1/2^\circ$.
 2. WALL THICKNESS TO BE $.062$ UNLESS OTHERWISE SPECIFIED.
 3. ALL CORNERS TO BE $.015$ UNLESS OTHERWISE SPECIFIED.
 4. AREA = $.390$ SQ. IN.

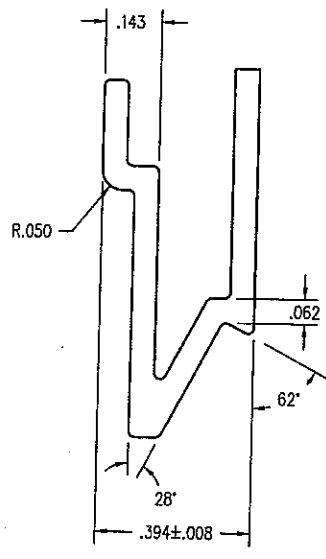
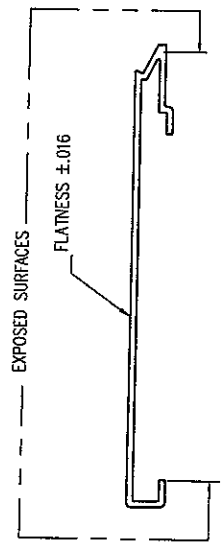
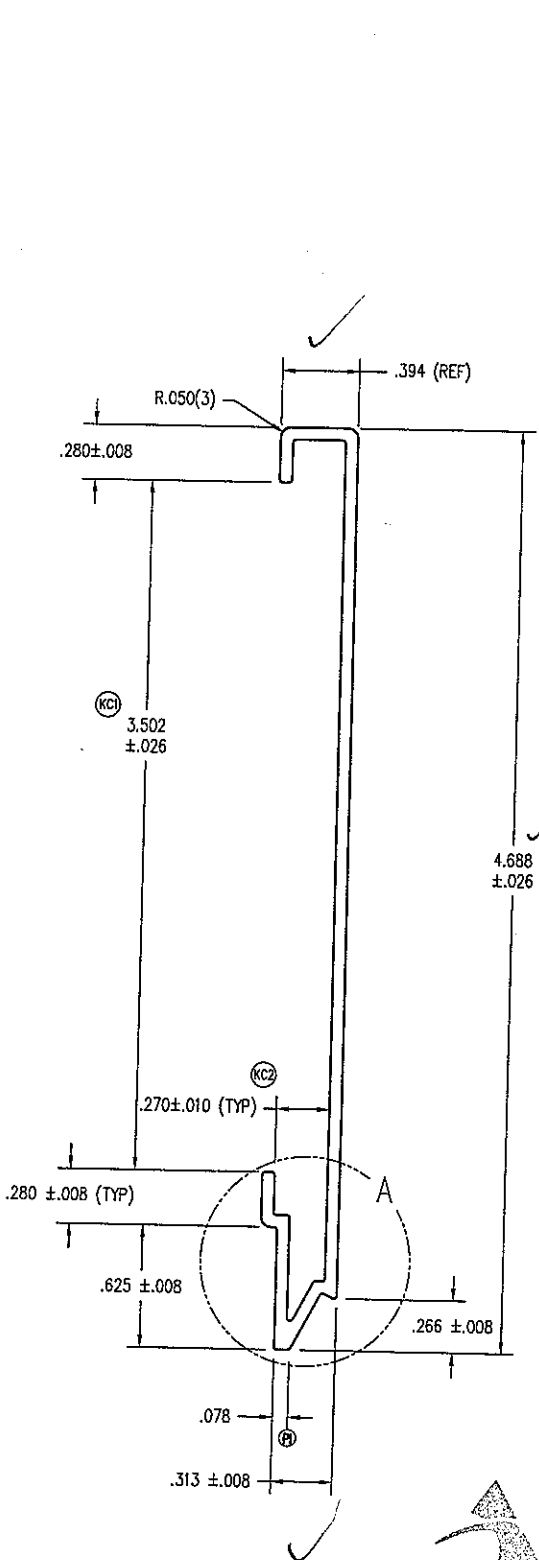

DETAIL A
SCALE: 2 = 1

Architectural Testing

Test sample complies with these details.
Deviations are noted.

Report# 68741
Date 11/8-9/06 Tech gpk

THIS DRAWING AND ITS CONTENTS ARE THE PROPERTY OF EAGLE WINDOW & DOOR. NO USE OR REPRODUCTION OF THE CONTENTS OF THIS DOCUMENT IS PERMITTED WITHOUT THE EXPRESS WRITTEN PERMISSION OF EAGLE WINDOW & DOOR.	
TITLE: 4 11/16" PANEL CLADDING INTERLOCK FIT	
FINISH: EAGLE'S STD. COLORS	
MATERIAL: 6063 T-6 ALUMINUM	
DFT: AWW	SCALE: 1=1
DCN: 0794	DRWG: A613
DATE: 7/14/2003	C 01 OF 03

NO	DESCRIPTION	DFT	DOC	DATE

- Note: 1. UNLESS OTHERWISE SPECIFIED, ALL DIMENSIONS ARE SHOWN ARE IN INCHES AND ALL TOLERANCES ARE TO BE: DEC. +/- .005, FRACTION +/- 1/64, ANGLES +/- 1/2.
 2. ALL WALL THICKNESS TO BE .090 UNLESS OTHERWISE SPECIFIED.
 3. ALL UNSPECIFIED RADII TO BE .015.
 4. RIDGID AREA = 0.256 SQ. IN.

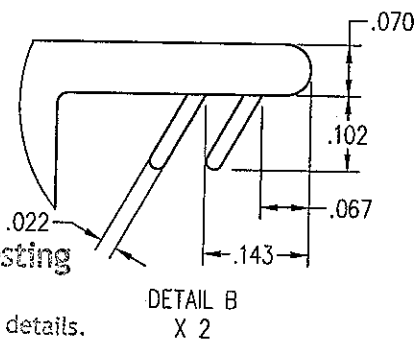
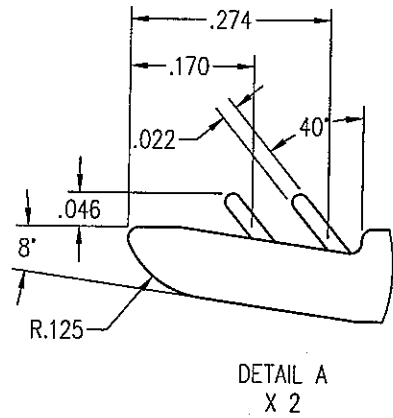
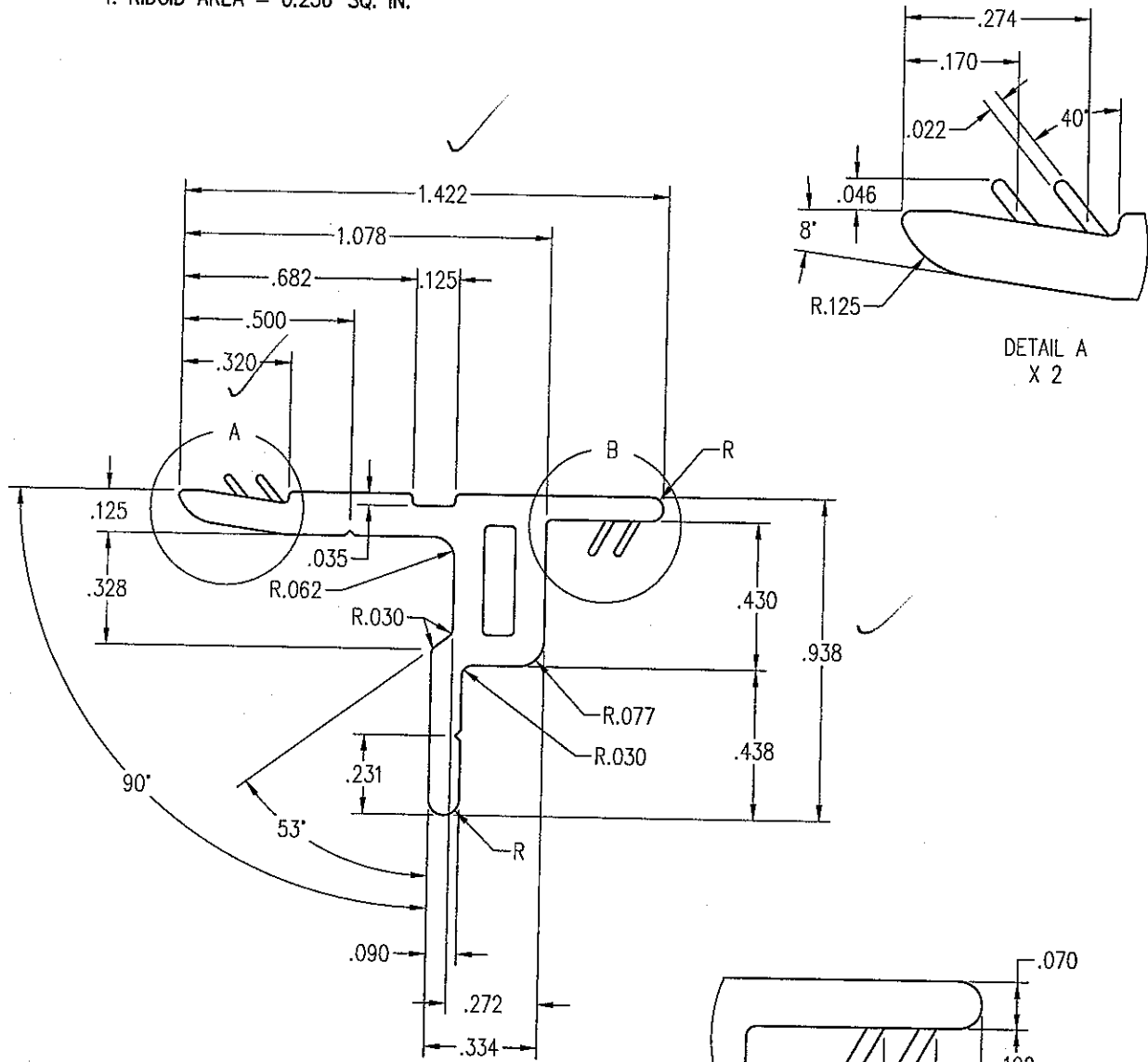

TOLERANCES (UNLESS NOTED)	
.000 - .125	±.010
.125 - .500	±.015
.500 - 2.00	±.020
2.00 - 4.00	±.030
4.00 - 5.00	±.040
WALLS	±.005
ANGLES	±3°

Architectural Testing

Test sample complies with these details.
 Deviations are noted.

Report# 68741
 Date 11/8-9/06 Tech gjk

NO	Description of Change	Drafter	DCN#	Date
	Title: OUTSWING SIDELITE / TRANSOM SHIM	Finish: BEIGE	Material: RIGID PVC (DUAL DUROMETER LEGS)	
Scale: 2"=1"	Date: 2/24/2005	THIS DRAWING AND ITS CONTENTS ARE THE PROPERTY OF EAGLE WINDOW & DOOR. NO USE OR REPRODUCTION OF THE CONTENTS OF THIS DOCUMENT IS PERMITTED WITHOUT THE EXPRESS WRITTEN PERMISSION OF EAGLE WINDOW & DOOR.		REVISION: A692
Drafter: tries	DCN#: 0836			0

- NOTE: 1. UNLESS OTHERWISE SPECIFIED, ALL DIMENSIONS SHOWN ARE IN INCHES AND ALL TOLERANCES ARE TO BE: DEC. ± 0.005 ; FRAC. $\pm 1/64$; ANGLES $\pm 1/2^\circ$.
2. APPROVED VENDOR: INTEK, PART #50135A.
3. .023/.017 TYP. WALL FLEX. .036/.030 TYP. WALL RIGID.
4. CHDVO, WHDVO, SINGLE PANEL: $L = \text{FRAME WIDTH} - 1.812$.
 CHDVO, ACTIVE PANEL: $L = (\text{FRAME WIDTH} / 2) - 1.343$.
 CHDVO, INACTIVE PANEL: $L = (\text{FRAME WIDTH} / 2) - .593$.
 WHDVO, ACTIVE PANEL: $L = (\text{FRAME WIDTH} / 2) - 1.312$.
 WHDVO, INACTIVE PANEL: $L = (\text{FRAME WIDTH} / 2) - .562$.
5. SIDE JAMB FOR CLAD & WOOD SLIDING DOORS ($L = \text{FRAME WIDTH} - 3$).

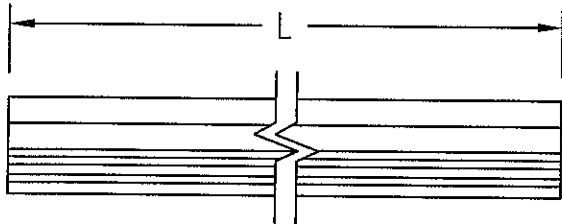

4

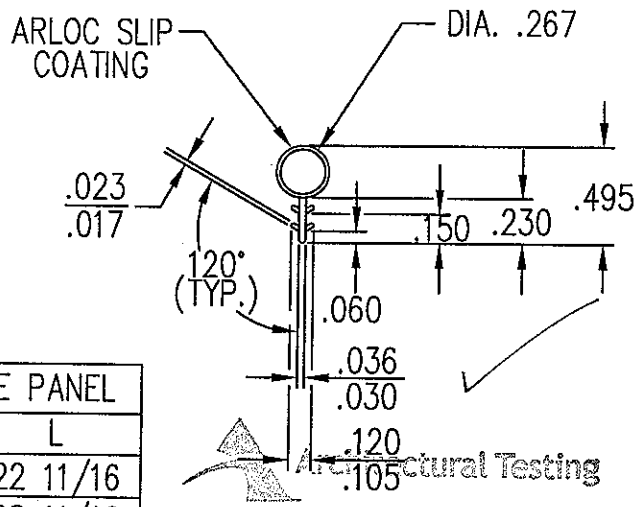

Structural Testing

Test sample complies with these details.
Deviations are noted.

Report# 68741

Date 11/8-9/00 Test OK

CHDVO, ACTIVE PANEL	
FRAME WIDTH	L
24 1/2	22 11/16
30 1/2	28 11/16
32 1/2	30 11/16
36 1/2	34 11/16
48 1/16	22 11/16
60 1/16	28 11/16
64 1/16	30 11/16
72 1/16	34 11/16

WHDVO, ACTIVE PANEL	
FRAME WIDTH	L
24 1/2	22 11/16
30 1/2	28 11/16
32 1/2	30 11/16
36 1/2	34 11/16
48	22 11/16
60	28 11/16
64	30 11/16
72	34 11/16

CHDVO, INACTIVE PANEL	
FRAME WIDTH	L
48 1/16	23 7/16
60 1/16	29 7/16
64 1/16	31 7/16
72 1/16	35 7/16

WHDVO, INACTIVE PANEL	
FRAME WIDTH	L
48	23 7/16
60	29 7/16
64	31 7/16
72	35 7/16

CLAD & WOOD SLIDING DRS.	
FRAME HEIGHT	L
80	77
82	79
96	93

THIS DRAWING AND ITS CONTENTS ARE THE PROPERTY OF EAGLE WINDOW & DOOR. NO USE OR REPRODUCTION OF THE CONTENTS OF THIS DOCUMENT IS PERMITTED WITHOUT THE EXPRESS WRITTEN PERMISSION OF EAGLE WINDOW & DOOR.

TITLE: ARLOC BULB WEATHERSTRIP

FINISH:

05	CHANGED TO PAGE 01 OF 04	RJW	0640	10/1/2003		
04	CHG'D SINGLE O/S DOOR WIDTH	TWN	0632	11/30/2000	MATL:	PPR
03	ADDED PAGES/REMOVED CHARTS	TWN	0486	4/9/2001		PROPYLENO/ETHYLONE COPOLYMER
02	ADDED SLIDING DR CHART	MJP	0444	4/3/2000	DFT:	TWN
01	ADDED 6-10 DOOR HGT.	MJP	0243	8/13/1997	DCN:	0231
NO	DESCRIPTION	DFT	DOC	DATE	DATE:	1/16/1996
					SCALE:	1=1
					DRWG:	A283
					A	01 OF 04

Note:1 UNLESS OTHERWISE SPECIFIED, ALL DIMENSIONS ARE SHOWN ARE IIN INCHES AND ALL TOLERANCES ARE TO BE: DEC.+/- .005, FRACTION +/- 1/64, ANGLES +/- 1/2.

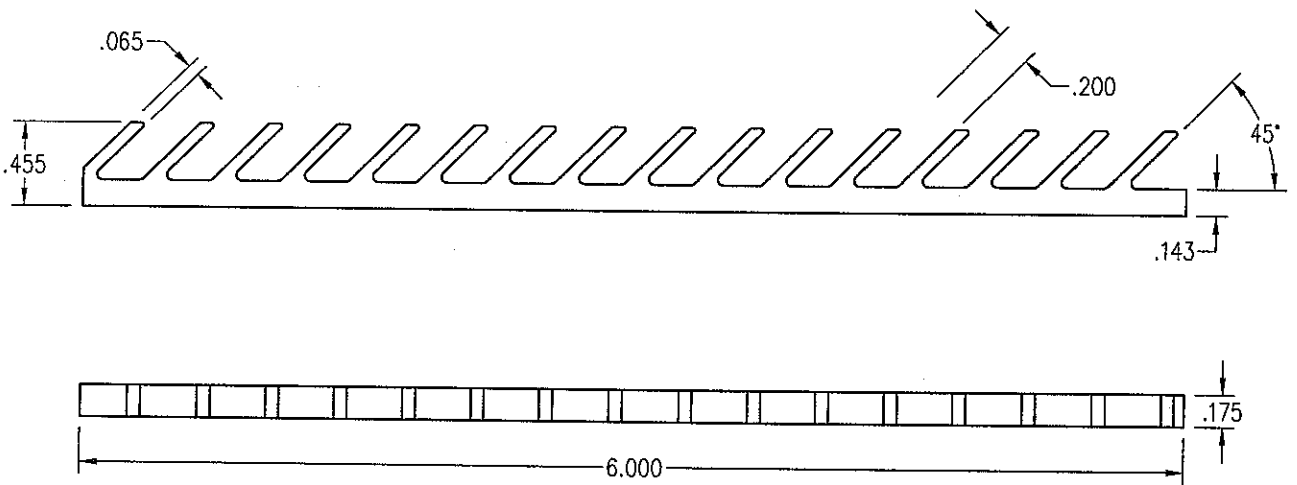

 Architectural Testing

Test sample complies with these details.
Deviations are noted.

Report# 68741
Date 11/8-9/06 Tech. JMK

NO	Description of Change	Drafter	DCN#	Date
	PANEL WEDGE		ST NYLON	
Scale: 1"=1"	Date: 5/9/2005	THIS DRAWING AND ITS CONTENTS ARE THE PROPERTY OF EAGLE WINDOW & DOOR. NO USE OR REPRODUCTION OF THE CONTENTS OF THIS DOCUMENT IS PERMITTED WITHOUT THE EXPRESS WRITTEN PERMISSION OF EAGLE WINDOW & DOOR.		REVISION: A699
Drafter: aweldin	DCN# 0736			0